



WORLD OF VISUAL COMMUNICATION

CATALOGUE 2012



**WHITEBOARDS
FLIPCHARTS
MARKERS
YEAR PLANNERS
ACCESSORIES
AND MORE!**



Legamaster 

We make communication visible

VISUALISE YOUR SUCCESS

To be convincing, your message needs to be clear and visible. To communicate efficiently, you need to see the complete picture. With its vast range of highly practical, well thought out products, Legamaster, the name in professional visual communication, has successfully established itself a place in the market.



PRESENTATION

Page 8–43

Whiteboards	9-22	Multiboard mobile	28
Glassboards	10	Stands and easels	29
Gridboards	14	Flipcharts	30-39
Conference units	15, 19	Flipchart accessory STARTER kit	40
Revolving whiteboards	15, 20	Presentation accessories	23, 41
Combiboards	21	Magic-Chart	22, 42-43
Pinboards	24-27		

MODERATION

Page 44–59

Moderation structure	45	Moderation accessories	55-59
Moderation boards	46-49	Moderation paper	55
Multiboard mobile	50	Magic-Chart	56
Carry bag	50	Moderation cards / Moderation cards Emoticons	57-58
Moderation cases	51-54	Presentation markers and refill ink	59
Moderation kit	55		

PRESENTATION AND DISPLAY

Page 60–75

Choose your ideal rail system	61	Legaline PROFESSIONAL rail system	68-73
Legaline DYNAMIC rail system	62-67	Whiteboards Legaline PROFESSIONAL	70
Whiteboards Legaline DYNAMIC	64	Pinboards Legaline PROFESSIONAL	70-71
Pinboards Legaline DYNAMIC	64	Flipchart Legaline PROFESSIONAL	71
Flipchart Legaline DYNAMIC	65	Shelves / rack Legaline PROFESSIONAL	72-73
Shelves / rack Legaline DYNAMIC	66	Projection screens Legaline PROFESSIONAL	73
Projection screens Legaline DYNAMIC	67	Cabinets	74
e-Board Interactive Legaline DYNAMIC	67	Presentation and display accessories	75

PROJECTION

Page 76–95

Choose your ideal projection screen	77-79	Manual projection screens	85-88
Easy install	79	Mobile projection screens	89-93
PROFESSIONAL projection board FLEX	80	Projection accessories	94-95
Electrical projection screens	81-84	Laser pointers	95

PLANNING

Page 96–117

Choose your ideal planner	97	Month planners	108
Year planners	98-102, 104-105, 107, 108	Planboards accessories	110
Sliding index	99	Planning sets	111
Activity planner	103	Cardboard year planners 2013	112-113
Multi purpose planners	104, 109	PROFESSIONAL channel planner	114
Week planners	106, 109	Channel planner accessories	114-115
Project planners	106	Slide index system	116-117
General planners	107	T-cards	117

INFORMATION

Page 118–131

Showcases	119-121	PROFESSIONAL maps	126-127
Key holder showcases	121	PREMIUM information boards	128
Poster frames	122	Doorplates and deskplates	129
Magnetic document holders	122	Letters and numbers	129
In & Out boards	123	EXPORAIL suspension system	130
Legaline PROFESSIONAL floor system	124-125	Information accessories	123, 131

ACCESSORIES

Page 132–153

Whiteboard accessoires	133-141	Presentation markers	142
Board markers	133-136	Refill ink for presentation markes	142
Refill ink for board markers	136	Flipchart accessory STARTER kit	143
Whiteboard erasers	137	Flipchart paper	144
Whiteboard cleaners	138	Magic-Chart	145
MagicWipe	139	Magnetic accessories	146-149
Board accessory kits	140-141	Planning accessories	150-151
Pinboards accessories: push and moderation pins	145	Projection accessories: laser pointers	152
Flipchart accessoires	142-144	Information accessories: letters and numbers	153

SERVICE

Page 154–165

Matrix whiteboards	154-155	Matrix projection screens	160-161
Matrix pinboards	156-157	Index (alphabetical order)	162-163
Matrix flipcharts	158-159	Index (reference number)	164-165

The Legamaster range is continually being updated and expanded. We expressly reserve the right to amend the range, the materials and the design, and to make alterations to the available colours and sizes. We cannot be held liable for typographical errors.

ABOUT US

Legamaster – Masters in Visualisation

The Legamaster label is part of the internationally renowned edding group, practising and maintaining the philosophy of its parent company.

It is a philosophy which ensures the high quality of all its products on the international stage, backed by local distribution and customer support.

The success of this approach is clearly visible: the Legamaster name stands for an even wider selection of products and better service. All under the same roof.

Take a look at our website www.legamaster.com for current promotions and product details.



Head Quarters Legamaster

Legamaster International B.V. · Kwinkweerd 62, Postbus 111
7240 AC Lochem, The Netherlands · Tel. (+31)-(0)573-713000
Fax (+31)-(0)573-713001 · e-mail: info@legamaster.com
www.legamaster.com



We can meet your personal request!

Production

We have our own production sites in Europe and South-America.

- Production is semi automatic
- Standardised production processes ensure a consistent high quality

Customised solutions

Our Made-to-Measure production expertise means we can meet your own personal requests.

- Can't find what you are looking for in our catalogue? Talk to us!

Logistics

We ensure speedy deliveries within Europe.

- We are consistently optimising the flow of goods and raw materials
- Thanks to our modern warehouses complete with high stack shelving, we can ensure an organised, speedy turnaround: from the raw material through to the finished product

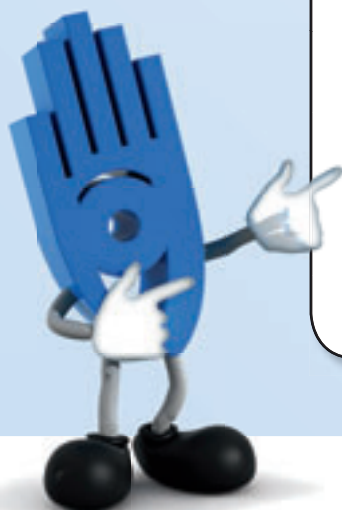

Welcome to the Legamaster catalogue!

My name is Leo, which stands for Legamaster for Education and Office.

I will show you around this catalogue and draw your attention to special features and elements of the Legamaster products.

I wish you a pleasant journey through the Legamaster catalogue.

Quality



Legamaster is a worldwide, high value premium brand in the field of visual communication. In order to meet the high standards required for both products and services, we have documented our practice and our quality objectives within a Quality Management System in accordance with **ISO 9001:2000**.

We have a standardised quality control system in place to keep a constant check on the entire Legamaster production processes. Legamaster's quality control follows internationally accepted standards and ensures the products work properly, are user friendly and meet safety requirements if required. A Production control and a Final Random Inspection covering visual and functional inspections are also carried out to ensure the constant high quality of Legamaster products. These quality controls use approved methods and tools for quality checks as well as procedures that are individually designed for certain products or product ranges.

In certain cases Legamaster's quality control uses internationally accepted technical institutes or experts for special tests and approval i.e. our Legaline DYNAMIC rail system which carries the safety label TÜV/GS.

Our raw materials are tested to the agreed specification and abilities before they leave our suppliers. They pass an additional inspection in our own quality control procedure before entering into further processes. Where we use component parts from other manufacturers, we commit them to providing us with the appropriate certificates concerning product safety and conformity with safety regulations if existing.

Guarantee

All Legamaster products are designed and manufactured to the highest quality standards. Legamaster products give a high performance level when used for the intended purpose, in accordance with operating instructions and in conjunction with original accessories or other products from the Legamaster range. All products are guaranteed during a period of 2 years from date of purchase in Europe.

Within the assortment we give specific guarantees for whiteboard and flipchart surfaces, indicated in the product information with logos.



Explanation of the Legamaster icons



Write on / dry wipe surface is guaranteed for 25 years when used in conjunction with Legamaster accessories



Write on / dry wipe surface is guaranteed for 10 years when used in conjunction with Legamaster accessories



Write on / dry wipe surface is guaranteed for 5 years when used in conjunction with Legamaster accessories



Write on / dry wipe surface is guaranteed for 2 years when used in conjunction with Legamaster accessories



Light-weight product, easy to handle



Information and written notices can be attached with Legamaster magnets



The reverse side of this product also has a working surface



Superior quality, scratch resistant, magnetic environmentally friendly certified e³ ceramic steel surface



Scratch resistant, magnetic, enamel / ceramic steel surface



Electrical product, electrical connection is required



Flexible installation of wall and ceiling projection screens, with a minimum amount of effort



Product can be mounted with block magnets
Ref.no. 7-1840 00



Product is also available in Cash & Carry packaging



Cap Off ink protects against rapid drying out



Barrel made of aluminium (markers)



The Paper by Nature organization promotes environmentally friendly practices in both the pulp and paper industry and the responsible use of paper by the consumer.



Find a digital version of the Legamaster catalogue on www.legamaster.com

CORPORATE SOCIAL RESPONSIBILITY

“IN THE INTEREST OF THE ENVIRONMENT – FOR THE WORLD OF TOMORROW.”

– strategy of edding AG –

As part of the edding group, Legamaster shares the strategic significance edding attaches to Corporate Social Responsibility (CSR). We endorse the edding vision regarding themes as human rights, child labor, discrimination and environment & sustainability. The Legamaster CSR principles are defined in our Code of Conduct.

The concept of CSR goes beyond the local impact of Legamaster's business to our extended supply chain. Legamaster recognizes its social position by imposing requirements on business partners and its own organization when it comes to the supply of Legamaster products and services.

We understand CSR as a continuous process of improvement and adaptation in an ever-changing environment. Our goal is to further develop CSR as a systematic and continuous process, to ensure meaningful changes in the key CSR areas: People, Planet & Profit.

Legamaster has started its CSR journey and will continue to implement initiatives to put its CSR commitment into action.

People

Guarantee health and safety at work

- Health and safety at work are key aspects of the Legamaster social policy.

Non-discrimination policy

- We reject any form of discrimination.

Respect human rights

- Legamaster respects human rights and expects business partners to share this vision.

Cooperation with partners that share the Legamaster values towards CSR

- We aim to do business with partners and suppliers that share our vision towards CSR related themes, we intend to bind them into our CSR processes and have them sign up to common values and sustainable business practices.



Profit

Taking care of our business and the environment

- Economics and efficiency
- Balancing economical targets with social & environmental targets

Consistent application of quality management system

- Legamaster is ISO 9001 certified



Planet

Energy saving policy

- Several energy-efficiency measures have been taken (installation of new energy-efficient heaters, optimizing thermostat settings, energy saving measures towards lighting, etc.).

Environment: key aspect in product development process

- Enamel steel boards are provided with environmentally friendly certified ceramic steel.
- Board frames are of 100% recyclable aluminium. All plastic board parts are 100% recyclable.
- The Triangle flipchart range comes with a 100% environmentally friendly packaging.
- Flipchart paper pads carry the Paper by Nature certificate.
- Magic-Chart is made out of environmentally friendly material and fully recyclable.
- Board- and presentation markers can be recycled, simply by using the refill ink!

Video-conferencing: in aid of the environment

- Our video-conferencing system makes numerous journeys between the Legamaster and edding head quarter unnecessary. In practice this leads to savings with regard to fuel consumption (car, airplane), reduced CO₂ emissions, less employee stress, time saving and reduced travel expenses.

Responsible printing-and copying policy

- We use 100% recycled paper bearing the Blue Angel environmental label. A double sided output policy and the use of digital technology has allowed us to reduce on paper usage. Digital copies are made instead of physical copies whenever possible. The replacement of outmoded individual printers with centralized multifunction units has improved power consumption. Ink cartridges are recycled.

Catalogue: naturally printed FSC certified paper

- This Legamaster catalogue is printed on FSC certified paper. A digital version of the catalogue can be consulted online, which can be considered a user- and environmentally friendly device.

Respect environmental regulations

- WEEE, REACH, RoHs and DMF.



INTERACTIVE SOLUTIONS

Legamaster offers a large variety of interactive solutions

Be it in a meeting room, a conference room, a classroom or an office, interactive products are increasingly commonplace. Legamaster offers a wide range of mobile and fixed interactive solutions to suit every purpose and any situation.

Interactive, digital, innovative: we set the benchmark



View the complete range of interactive products in our e-Catalogue and discover how to make your presentations or lessons more productive, interactive and professional.



Need help in selecting the ideal interactive solution from Legamaster?

Our sales teams will be happy to advise you about our possibilities by giving you more information and answering your questions about our interactive products.

You can also reach us 24 hours a day at www.e-legamaster.com

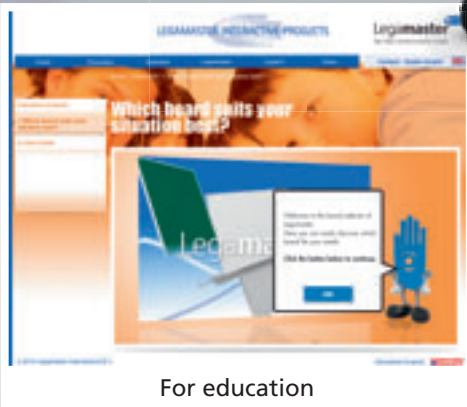

For education

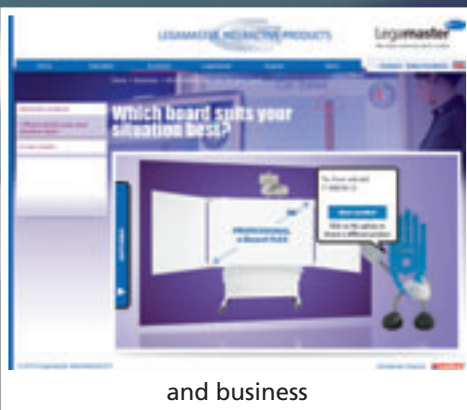

and business



Along with product information, you can also get acquainted with our interactive software. Work with an online software tool for a quick and easy insight into our user-friendly software and experience its look and feel.

We know that each situation is unique and that each user has a different interactive target. That's why we've included a board selector on our website. Answer a few simple questions in the board selector to see which interactive board suits your situation best.

As well as taking advantage of these tools, you can visit the website for free software updates, to download files from other users, view demonstration movies and enter competitions to win fabulous prizes!

PRESENTATION

The spoken word is not always fully heard with only part of the message being understood, but by stimulating more senses, your words will be remembered. Therefore, a well arranged office, conference or meeting room is a decisive factor in ensuring a successful meeting.

Legamaster offer a wide range of whiteboards, pinboards and flipcharts that will help strengthen your spoken word and visually communicate your information. For every situation we offer a solution.





3 kinds of whiteboard surface:

The most important feature of a whiteboard is the surface. The best surface for your situation depends on how you will use the whiteboard. Herewith you find an overview with the characteristics and qualities of every whiteboard surface:

1 Enamel steel

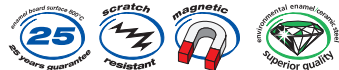
- Quality of this surface: long-term intensive use
- The highest quality whiteboard surface, guaranteed for 25 years when used in conjunction with Legamaster accessories
- Ink wipes off easily, even after a prolonged period of time
- The surface is scratch resistant, therefore ink from markers used by mistake (e.g. permanent markers) can also be removed without damaging the surface
- The surface is acid resistant and withstands cleaning even with the toughest detergents
- The enamel steel Legamaster uses for its whiteboards has a high quality, very hard baked enamel finish, it is fired at 800°C
- Magnetic: information and written notices can be attached with magnets
- The enamel boards of Legamaster are provided with environmentally friendly certified e³ ceramic steel



UNIVERSAL^{PLUS} and ECONOMY^{PLUS} have a different quality enamel surface. The surface has similar properties as mentioned above, but with a  quality level.



2 Lacquered steel

- Quality of this surface: long-term regular use
- The lacquered steel surface has a special coating, suitable for writing on with dry wipe alcohol-based board markers
- Magnetic: information and written notices can be attached with magnets



3 Melamine

- Quality of this surface: regular use
- Melamine resin surface: scratch and pressure resistant to a certain extend
- Suitable for writing on with dry wipe alcohol-based board markers
- Non-magnetic



Method of handling and mounting:

The advantage of...

1 ... a "light-weight" whiteboard construction

This makes the board easier to handle, especially for the bigger sizes, offering a solution for walls that cannot carry much weight.



Light weight boards can be recognized by this icon

2 ... a "concealed slot system"

A concealed slot system provides you convenience, stability and flexibility.

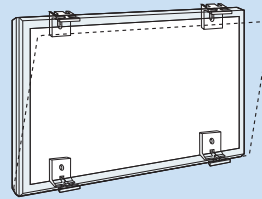

Convenience:

The board has four slots so you can hang the board on the wall by placing it on the two lower slots, before you attach the two upper slots. This enables you in many cases to hang the board on the wall without assistance of a second person.

Stability and flexibility:

The four slots used for mounting the board can be placed at any horizontal position on the board. Ideal with partition walls where the horizontal position of the possible holes in the wall are limited! Besides that, bigger sized boards get more stability from the well-positioned slots, compared to a mounting only at the corners.

3 ... a "corner wall mount"



The board is mounted through the four corners, simply by using the included screws and plugs. Finally, the corners are covered by corner caps. After mounting, the screws and plugs are no longer visible.

4 ... block magnet mounted



Block magnets are the perfect solution for hanging boards on metal-system walls and partitions.



The board can be mounted **without drilling holes**, and there are no tools needed to attach the board. The self adhesive, magnetic blocks have high holding power – the attached board will not move. Block magnets are for boards with a steel backing only.

Ref.no. 7-184000



On page 154 you find a whiteboard matrix, with all board details.



PRESENTATION

Glassboards PURE "optical white"



- Unique design with all the functionalities of a professional magnetic whiteboard
- Particularly well suited for intensive and long term use
- Glassboard of 5 mm "optical white" safety glass. The surface is hardened glass where the normal (green) glass colour nuances have been eliminated in a special process, leaving a clear, white glass
- Anodised aluminium frame that runs fully over top and bottom of the board
- Can be written on with whiteboard markers and dry wipe-able
- Magnetic board surface, notes can be stuck to the board with special glassboard magnets
- Excellent writing capacities because of the smooth surface
- Stain and scratch resistant board surface
- Easy to clean, resistant to detergents
- Comes complete with fixing kit
- Please note: screws are not included in the delivery: each wall requires wall-specific screws for the particular on-site situation

Height x Width	Weight	Ref.no.
104 x 117.5 cm	16 kg	7-100754
104 x 147.5 cm	20 kg	7-100763
104 x 197.5 cm	26 kg	7-100764



- Wall mounting construction supports the board approximately 30 mm off the wall, creating the impression of floating
- Special nicely designed glassboard magnets are strongly advised; as normal whiteboard magnets do not function properly on the glassboard surface!
- Write on / dry wipe surface is guaranteed for 25 years when used in combination with Legamaster accessories



Recommended accessories:
 Marker tray in plexiglass 330 mm
 Ref.no. 7-126700
 Extra strong magnets 30 mm,
 packed per 5 pieces
 Ref.no. 7-181600

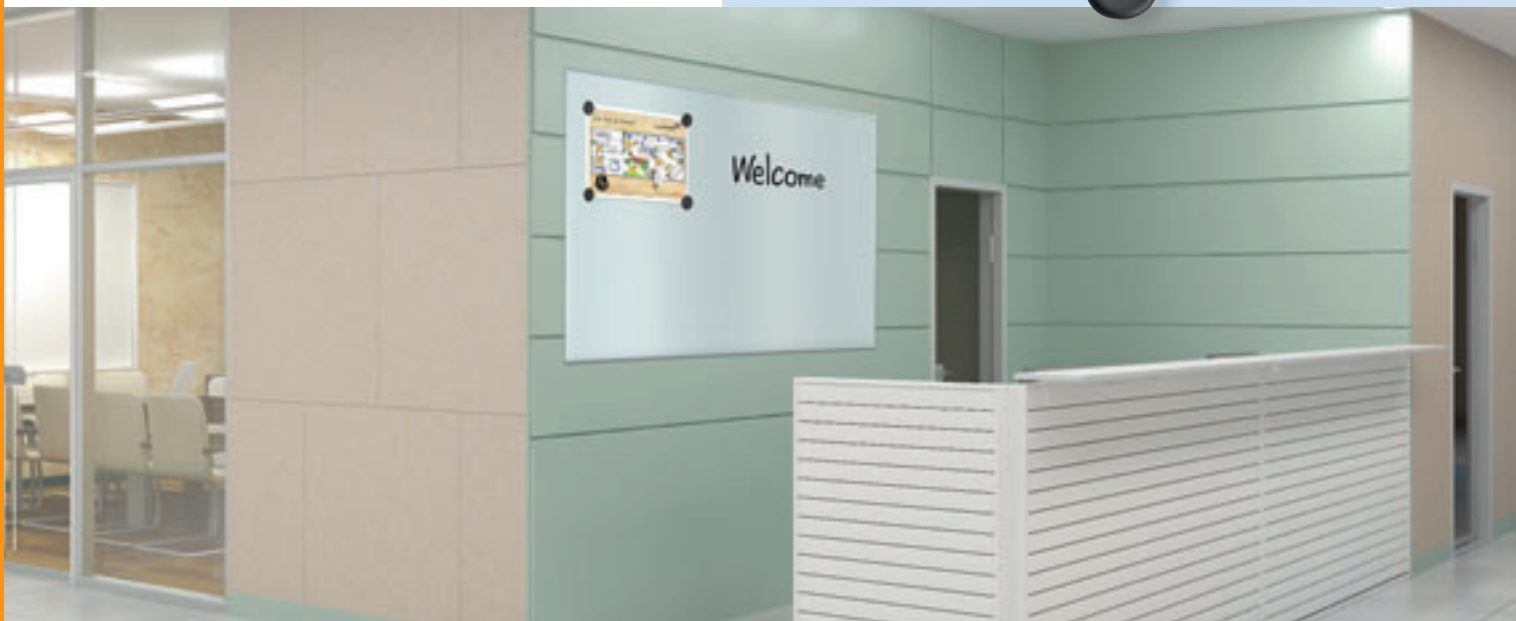

DYNAMIC whiteboards



- Design aluminium frame with light grey plastic corner caps
- High quality, scratch resistant enamel surface
- Particularly well suited for long-term use
- Write on / dry wipe surface is guaranteed for 25 years when used in combination with Legamaster accessories
- Weight: approx. 9 kg/m²
- Ready to use: comes complete with fixing kit, marker tray, 4 board markers and eraser

Height x Width	Ref.no.
60 x 90 cm	7-100943
90 x 120 cm	7-100954
90 x 180 cm	7-100956
100 x 150 cm	7-100963
100 x 200 cm	7-100964
120 x 180 cm	7-100974



Recommended accessories:

The DYNAMIC whiteboard eraser which fits into the pivotal marker tray can also be ordered separately
Ref.no. 7-120900

Block magnets
Ref.no. 7-184000

Block magnets are the perfect solution for hanging boards on metal-system walls and partitions.

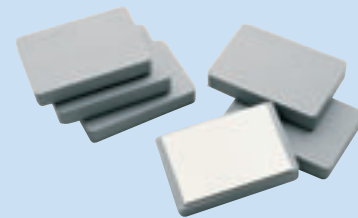

- Specially constructed wall mount provides a stylish "three dimensional" look. The board "floats" in front of the wall

- Pivotal marker tray can be stored behind the board at the left or right side

PRESENTATION

IMAGINE COLOUR whiteboards



- A distinctive whiteboard with clear lines and exquisite attention to detail by using a subtle colour element in the frame
- Available standard with classic blue label strip, but with the option of 8 additional exchangeable solid and transparent colours
- The IMAGINE whiteboard is part of the IMAGINE product family. The IMAGINE family also offers a flipchart
- High quality, scratch resistant enamel board surface
- Anodised aluminium frame with a coloured label and light grey plastic corner caps
- Easy wall mounting with concealed slot system
- Modern stylish marker tray ("swoosh") including matching colour label, to be ordered separately
- Write on / dry wipe surface is guaranteed for 25 years when used in combination with Legamaster accessories
- Weight: approx. 13 kg/m²
- Comes complete with classic blue label strip, integrated minimalistic marker tray, fixing kit and TZ 14 retractable marker

Height x Width	Ref.no.
70 x 120 cm	7-101610
90 x 160 cm	7-101611
120 x 210 cm	7-101612



Personalise your IMAGINE whiteboard with one of the 8 colour labels!



IMAGINE COLOUR label and swoosh

How to select a coloured label strip and a swoosh for your IMAGINE whiteboard:

STEP 1

Look for your IMAGINE whiteboard in the overview

STEP 2

Select your required colour and decide if you want to change the colour of the label strip, or if you prefer a label strip and a swoosh in a specific colour

STEP 3

Please order your distinctive colour choice

Lenght label + swoosh	Ref.no.	
120 cm	7-1258xx	Just add the right
160 cm	7-1259xx	colour code to Ref.no.
210 cm	7-1260xx	



On request it is possible to print the label in your corporate identity with your own logo.



- All IMAGINE COLOUR family members, standard in classic blue, have the possibility to easily exchange the colour labels and the "swoosh" (modern stylish marker tray)
- Colours: ultra black, chili red, classic blue, fresh lime (green), bright orange, lovely lilac, arctic blue and ocean blue

Set of 8 different whiteboard colour labels assorted 120 cm, to fit whiteboards with width 120 cm

Set of labels (without swoosh)
Ref.no. 7-126600

Set of 8 different whiteboard colour labels assorted 210 cm, to fit whiteboards with width 160 cm and 210 cm

Set of labels (without swoosh)
Ref.no. 7-126601

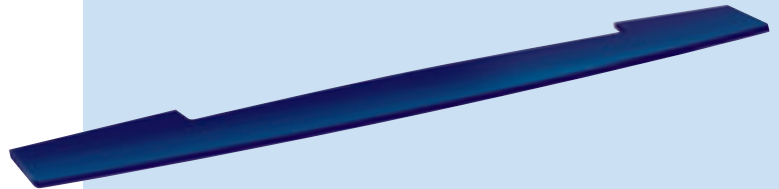

Colour label

- Attractive coloured label strip; imprinted with the IMAGINE logo
- Label strip along the bottom side of the board and can easily be replaced by a different colour label
- This to complement every interior and corporate identity
- A set of 8 assorted colour labels can be ordered separately. The length of the label can be easily cut to the correct size

Swooshes

- Designer "swoosh" which serves as a marker tray
- Swooshes can be clicked onto the existing minimalistic aluminium marker tray along the bottom side of the board
- Please note that swooshes need to be ordered separately; swooshes are always delivered with a free colour label matching its colour and size!



PRESENTATION

PROFESSIONAL whiteboards



- High quality, scratch resistant enamel surface
- Particularly well suited for long term use
- Aluminium frame with light grey plastic corner caps
- Can be mounted either horizontally or vertically
- Easy wall mounting with concealed slot system
- Write on / dry wipe surface is guaranteed for 25 years when used in combination with Legamaster accessories
- Length of marker tray = board height
- Weight: approx. 9 kg/m²
- Comes complete with fixing kit, marker tray and board marker

Height x Width	Ref.no.	Height x Width	Ref.no.
45 x 60 cm	7-100035	120 x 150 cm	7-100073
60 x 90 cm	7-100043	120 x 180 cm	7-100074
75 x 100 cm	7-100048	120 x 200 cm	7-100075
90 x 120 cm	7-100054	120 x 240 cm	7-100076
90 x 180 cm	7-100056	120 x 300 cm	7-100077
100 x 150 cm	7-100063	155 x 200 cm	7-100083
100 x 200 cm	7-100064	155 x 300 cm	7-100085
120 x 120 cm	7-100072		



Recommended accessories:
Whiteboard accessory set:
PROFESSIONAL kit Ref.no. 7-125500

PROFESSIONAL gridboards



- High quality, scratch resistant enamel surface
- Particularly well suited for long term use
- Aluminium frame with light grey plastic corner caps
- Can be mounted either horizontally or vertically
- Easy wall mounting with concealed slot system
- This enamel finish is double fired at 800°C. Besides the whiteboard surface, the grid is baked as well
- Write on / dry wipe surface is guaranteed for 25 years when used in combination with Legamaster accessories
- Length of marker tray = board height
- Weight: approx. 9 kg/m²
- Comes complete with fixing kit, marker tray and board marker

Height x Width	Ref.no.
60 x 90 cm	7-100143
90 x 120 cm	7-100154
100 x 150 cm	7-100163
100 x 200 cm	7-100164



Recommended accessories:
Whiteboard accessory set:
PROFESSIONAL kit Ref.no. 7-125500



Shown actual size

- Grid size: 10 x 10 mm
- Overprinted with 50 x 50 mm squares

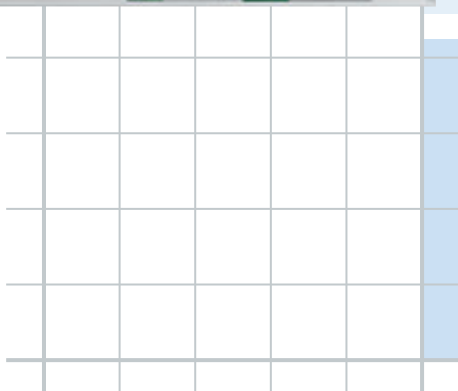

PROFESSIONAL conference units

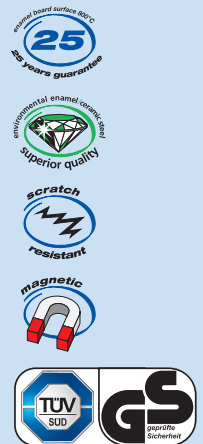

- High quality, scratch resistant enamel steel board surface with 25 year guarantee
- Particularly well suited for long term use
- Space saving because of 2-door system
- Large writing area thanks to double-sided doors
- Ideal for conference rooms and classrooms
- Excellent write on / dry wipe magnetic board surface for notes, pictures or posters
- Very easy to clean because of smooth surface
- Aluminium frame with light grey plastic corner caps

- Includes 2 clips for holding the doors neatly closed
- Comes complete with fixing kit, marker tray and board marker

Height x Width	Main board H x W	Doors H x W	Total weight	Ref.no.
90 x 120 / 240 cm	90 x 120 cm	90 x 60 cm	appr. 22 kg	7-100354
100 x 150 / 300 cm	100 x 150 cm	100 x 75 cm	appr. 30 kg	7-100363
100 x 200 / 400 cm	100 x 200 cm	100 x 100 cm	appr. 38 kg	7-100364

Recommended accessories:
Whiteboard accessory set: PROFESSIONAL kit Ref.no. 7-125500

PROFESSIONAL revolving whiteboards



- Easy to use
- Double-sided, scratch resistant enamel surface
- 360° pivot feature
- Can be set to any position
- Mobile stand, with 4 castors (2 lockable)
- Powder coated white (RAL 9016) stand and board frame
- Write on / dry wipe surface is guaranteed for 25 years when used in combination with Legamaster accessories
- Board and stand packed separately

Height x Width	Sizes (board and stand) H x W x D	Ref.no.
90 x 120 cm	190 x 137 x 75 cm	7-100454
100 x 150 cm	195 x 167 x 75 cm	7-100463
100 x 200 cm	195 x 217 x 75 cm	7-100464



Recommended accessories:
Whiteboard accessory set:
PROFESSIONAL kit
Ref.no. 7-125500



PRESENTATION

PREMIUM^{PLUS} whiteboards



- High quality, scratch resistant enamel surface
- Particularly well suited for long term use
- Aluminum frame with offwhite plastic corner caps
- Can be mounted either horizontally or vertically
- Easy wall mounting with concealed slot system
- Write on / dry wipe surface is guaranteed for 25 years when used in combination with Legamaster accessories
- 30 cm marker tray, except for ref.no. 7-101033: 20 cm
- Weight: approx. 13 kg/m²
- Comes complete with fixing kit, marker tray and board marker

Height x Width	Ref.no.	Height x Width	Ref.no.
30 x 45 cm	7-101033	100 x 200 cm	7-101064
45 x 60 cm	7-101035	120 x 120 cm	7-101072
60 x 90 cm	7-101043	120 x 150 cm	7-101073
75 x 100 cm	7-101048	120 x 180 cm	7-101074
90 x 120 cm	7-101054	120 x 200 cm	7-101075
90 x 180 cm	7-101056	120 x 240 cm	7-101076
100 x 150 cm	7-101063		



Recommended accessories:
Whiteboard accessory set:
PROFESSIONAL kit Ref.no. 7-125500



PREMIUM whiteboards



- Lacquered steel surface with a special coating
- Aluminium frame with dark grey plastic corner caps
- Can be mounted either horizontally or vertically
- Easy wall mounting with concealed slot system
- 30 cm marker tray except for Ref.no. 7-102033: 20 cm
- Weight: approx. 12 kg/m²
- Comes complete with fixing kit, marker tray and board marker

Height x Width	Ref.no.	Height x Width	Ref.no.
30 x 45 cm	7-102033	90 x 180 cm	7-102056
45 x 60 cm	7-102035	100 x 150 cm	7-102063
60 x 90 cm	7-102043	100 x 200 cm	7-102064
75 x 100 cm	7-102048	120 x 150 cm	7-102073
90 x 120 cm	7-102054	120 x 180 cm	7-102074

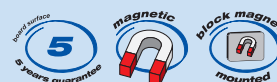

Recommended accessories:
Whiteboard accessory set:
STARTER kit Ref.no. 7-125000



For more information about the different board surfaces see page 9.

UNIVERSAL^{PLUS} whiteboards



- Scratch resistant enamel surface
- Suitable for writing on with dry wipe board markers
- Aluminium frame with light grey corner caps
- Can be mounted either horizontally or vertically
- Secure corner wall mount with corner caps
- Marker tray 30 cm
- Weight: approx. 11 kg/m²
- Comes complete with fixing kit and 30 cm marker tray

Height x Width	Ref.no.
45 x 60 cm	7-102135*
60 x 90 cm	7-102143*
90 x 120 cm	7-102154*
90 x 180 cm	7-102156
100 x 150 cm	7-102163
100 x 200 cm	7-102164



Recommended accessories:
Whiteboard accessory set:
STARTER kit Ref.no. 7-125000



UNIVERSAL whiteboards



- Lacquered steel surface with a special coating
- Suitable for writing on with dry wipe board markers
- Aluminium frame with dark grey corner caps
- Can be mounted either horizontally or vertically
- Secure corner wall mount with corner caps
- Marker tray 30 cm
- Weight: approx. 10 kg/m²
- Comes complete with fixing kit and 30 cm marker tray

Height x Width	Ref.no.
45 x 60 cm	7-102235*
60 x 90 cm	7-102243*
90 x 120 cm	7-102254*
90 x 180 cm	7-102256
100 x 150 cm	7-102263
100 x 200 cm	7-102264

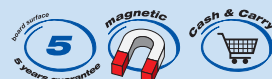

Recommended accessories:
Whiteboard accessory set:
BASIC kit Ref.no. 7-125100



* Also available in cash&carry packaging

PRESENTATION

ECONOMY^{PLUS} whiteboards



- Economic choice for frequent users
- Enamelled scratch resistant board surface
- Magnetic, notes can be stuck to the board with magnets
- Write on / dry-wipe board surface, suitable for writing on with board markers
- Aluminium frame with light grey plastic corner caps
- Can be mounted either horizontally or vertically
- Concealed wall mount
- Marker tray with end caps (30 cm), to store a range of board markers
- Weight: approx. 6 kg/m²
- Comes complete with fixing materials, marker tray and mounting instructions

Height x Width	Ref.no.
45 x 60 cm	7-102735
60 x 90 cm	7-102743
90 x 120 cm	7-102754
100 x 150 cm	7-102763
120 x 180 cm	7-102774



Recommended accessories:
Whiteboard accessory set:
STARTER kit Ref.no. 7-125000



ECONOMY whiteboards

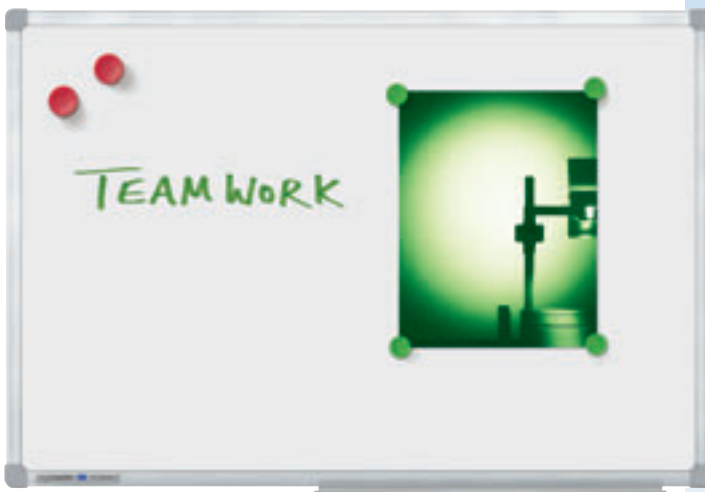

- Lacquered steel board surface
- Magnetic, notes can be stuck to the board with magnets
- Write on / dry-wipe board surface, suitable for writing on with board markers
- Aluminium frame with light grey plastic corner caps
- Can be mounted either horizontally or vertically
- Concealed wall mount
- Marker tray with end caps (30 cm), to store a range of board markers
- Weight: approx. 6 kg/m²
- Comes complete with fixing materials, marker tray and mounting instructions

Height x Width	Ref.no.
45 x 60 cm	7-102835
60 x 90 cm	7-102843
90 x 120 cm	7-102854
100 x 150 cm	7-102863
120 x 180 cm	7-102874

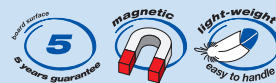

Recommended accessories:
Whiteboard accessory set:
BASIC kit Ref.no. 7-125100



ECONOMY^{PLUS} / ECONOMY conference units



- Large writing space: five separate writing areas
- Lacquered or enamel steel board surface
- Magnetic, notes can be stuck to the conference unit with magnets
- Write on / dry-wipe board surface suitable for writing on with board markers
- Small magnets on the inside of the wings ensure that the conference unit closes smoothly
- Aluminium frame with light-grey plastic corner caps
- Marker tray (30 cm) with end caps, to store a range of board markers
- Comes complete with fixing materials, marker tray and mounting instructions

ECONOMY^{PLUS} conference units

This board has a high quality enamel steel board surface.

For this type of board surface write on / dry wipe surface is guaranteed for 10 years when used in combination with Legamaster accessories.

Height x Width	main board H x W	doors H x W	total weight	Ref.no.
90 x 120 / 240 cm	90 x 120 cm	90 x 60 cm	appr. 13 kg	7-100554
100 x 150 / 300 cm	100 x 150 cm	100 x 75 cm	appr. 20 kg	7-100563
100 x 200 / 400 cm	100 x 200 cm	100 x 100 cm	appr. 24 kg	7-100564

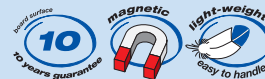

ECONOMY conference units

This board has a lacquered steel board surface.

For this type of board surface write on / dry wipe surface is guaranteed for 5 years when used in combination with Legamaster accessories.

Height x Width	main board H x W	doors H x W	total weight	Ref.no.
90 x 120 / 240 cm	90 x 120 cm	90 x 60 cm	appr. 8 kg	7-100254
100 x 150 / 300 cm	100 x 150 cm	100 x 75 cm	appr. 12 kg	7-100263
100 x 200 / 400 cm	100 x 200 cm	100 x 100 cm	appr. 15 kg	7-100264

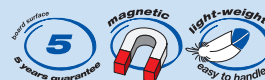

Recommended accessories:
Whiteboard accessory set:
STARTER kit Ref.no. 7-125000



PRESENTATION

ECONOMY^{PLUS} / ECONOMY revolving whiteboards



- Double-sided lacquered or enamel steel surface
- 360° pivot feature
- Switch from one writing area to the other easily by turning the board and setting it to its new position
- Mounted on a robust and very stable board stand (RAL 7045)
- Mobile stand with 4 black castors (2 lockable); Can easily be moved from one meeting room to the other
- Comes with marker tray (100 cm) and mounting materials
- Board and stand are packed separately

ECONOMY^{PLUS} revolving whiteboards

This board has a high quality enamel steel board surface.

For this type of board surface write on / dry wipe surface is guaranteed for 10 years when used in combination with Legamaster accessories.

Height x Width	Sizes (board and stand) H x W x D	Ref.no.
90 x 120 cm	191 x 127 x 65 cm	7-103554
100 x 150 cm	196 x 157 x 65 cm	7-103563
100 x 200 cm	196 x 207 x 65 cm	7-103564



ECONOMY revolving whiteboards

This board has a lacquered steel board surface.

For this type of board surface write on / dry wipe surface is guaranteed for 5 years when used in combination with Legamaster accessories.

Height x Width	Sizes (board and stand) H x W x D	Ref.no.
90 x 120 cm	191 x 127 x 65 cm	7-103654
100 x 150 cm	196 x 157 x 65 cm	7-103663
100 x 200 cm	196 x 207 x 65 cm	7-103664



Recommended accessories:
Whiteboard accessory set:
STARTER kit Ref.no. 7-125000

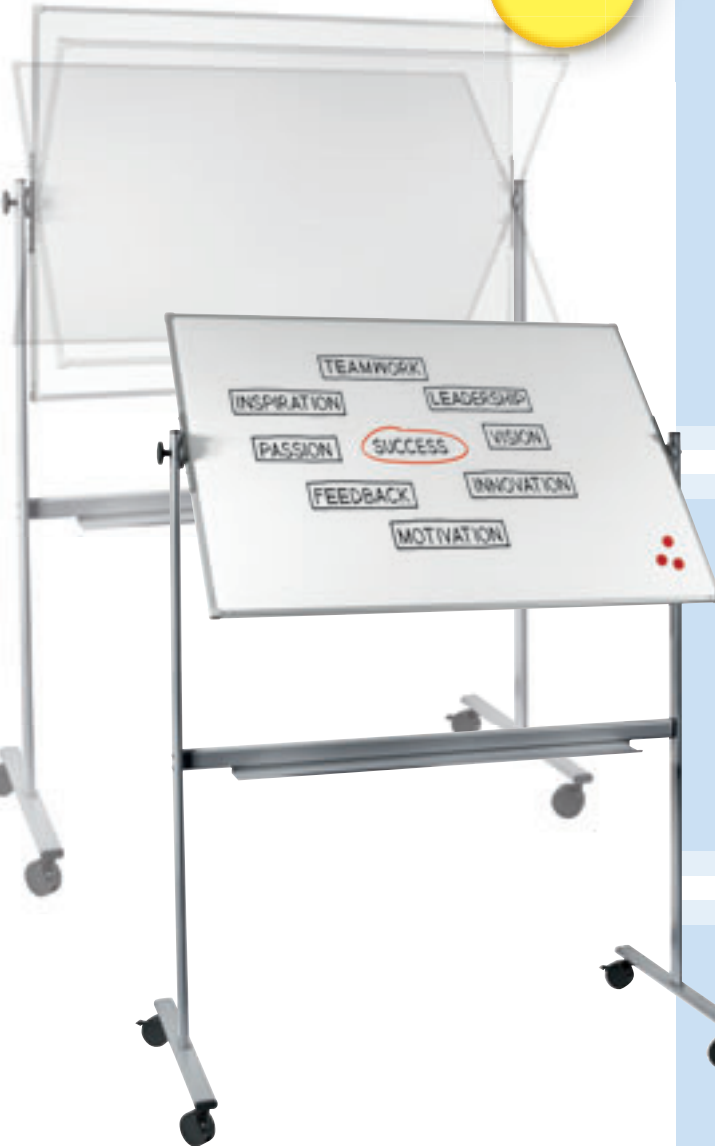

ECONOMY combiboards



- Space-saving dual-function board
- One half is a dry-wipe whiteboard with a lacquered steel board surface
 - Write on / dry-wipe board surface, suitable for writing on with board markers
 - Magnetic, notes can be stuck to the board with magnets
- One half is a pinboard with a natural cork board surface
 - Information and written notices can be attached to the board using push pins
- Aluminium frame with light-grey plastic corner caps
- Can be mounted either horizontally or vertically
- Concealed wall mount
- Marker tray with end caps (30 cm), to store a range of board markers
- Weight: approx. 5 kg/m²
- Comes complete with fixing materials, marker tray and mounting instructions

Height x Width	Ref.no.
60 x 90 cm	7-102443
90 x 120 cm	7-102454

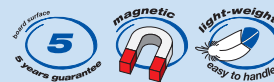

Recommended accessories:
 Whiteboard accessory set: BASIC kit Ref.no. 7-125100
 Push-pins in assorted colours Ref.no. 7-1451xx

ACCENTS Linear whiteboards – Cool



- Lacquered steel surface with special coating, suitable for writing on with dry wipe alcohol-based board markers
- Design frame "Cool" with a gradient from dark to light colour
- Wall mount with L hooks
- Light-weight
- Marker tray 18 cm
- Weight: approx. 5 kg/m²
- Also available: ACCENTS Linear planners
- Comes complete with fixing materials, marker tray and board marker

Height x Width	Ref.no.
30 x 40 cm	7-103133*
40 x 60 cm	7-103135*
60 x 90 cm	7-103143*
90 x 120 cm	7-103154



* Also available in cash&carry packaging

Recommended accessories:
 Whiteboard accessory set:
 STARTER kit Ref.no. 7-125000



PRESENTATION

BASIC whiteboards

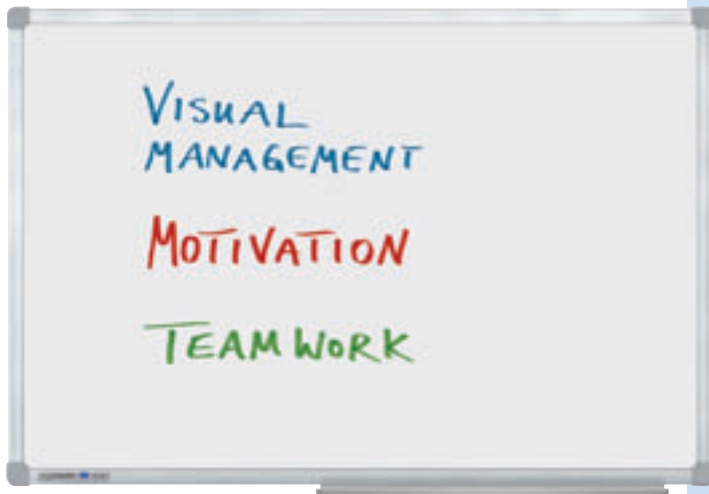

- Melamine resin surface
- Aluminium frame with light grey plastic corner caps
- Can be mounted either horizontally or vertically
- Concealed wall mount
- 30 cm marker tray with end caps
- Weight: approx. 7 kg/m²
- Comes complete with fixing materials and marker tray

Height x Width	Ref.no.
45 x 60 cm	7-102935
60 x 90 cm	7-102943
90 x 120 cm	7-102954
120 x 180 cm	7-102974



Recommended accessories:
Legamaster board markers, eraser and board cleaner, see next page



Magic-Chart

Ready-to-use large writing sheets for any meeting, spontaneous or planned.

Magic-Chart	Grid size	Ref.no.
Magic-Chart whiteboard	-	7-159100
Magic-Chart blackboard	-	7-159200
Magic-Chart flipchart	2.5 x 2.5 cm	7-159000



Produced in an environmentally friendly way and completely recyclable

Magic-Chart whiteboard
Fully white Magic-Chart foil
(whiteboard effect)



Magic-Chart flipchart
Fully gridded Magic-Chart foil
(flipchart effect)



Magic-Chart blackboard
Fully black Magic-Chart foil
(black chalkboard effect)



For more information
about Magic-Chart
See page 42.

Whiteboard accessories



Retractable marker TZ 14	Ref.no. 7-1125xx	page 133
Board marker TZ 1	Ref.no. 7-1100xx	page 133
Board marker TZ 100	Ref.no. 7-1105xx	page 134
Board marker PLUS TZ 10	Ref.no. 7-1110xx	page 134
Board marker TZ 140	Ref.no. 7-1140xx	page 135
Board marker TZ 150	Ref.no. 7-1150xx	page 135
Board marker JUMBO TZ 180	Ref.no. 7-1180xx	page 135
Board marker MINI TZ 111	Ref.no. 7-1111xx	page 136

Refill ink for board markers	Ref.no. 7-1195xx	page 136
Refill ink for board markers	Ref.no. 7-1199xx	page 136
Refill ink for TZ 14	Ref.no. 7-1129xx	page 136

Small whiteboard eraser	Ref.no. 7-120100	page 137
Magnetic whiteboard eraser	Ref.no. 7-120300	page 137
Whiteboard eraser TZ 4	Ref.no. 7-120500	page 137

Whiteboard cleaner TZ 6	Ref.no. 7-121000	page 138
Whiteboard cleaner TZ 7	Ref.no. 7-121200	page 138
Whiteboard cleaner TZ 8	Ref.no. 7-121300	page 138
Whiteboard cleaner TZ 66	Ref.no. 7-121400	page 138
MagicWipe	Ref.no. 7-121500	page 139

Marker holder	Ref.no. 7-122000	page 139
Board assistant	Ref.no. 7-122500	page 139
Flipchart pad holder	Ref.no. 7-123000	page 144

Whiteboard accessory set: PROFESSIONAL kit	Ref.no. 7-125500	page 140
Whiteboard accessory set: STARTER kit	Ref.no. 7-125000	page 141
Whiteboard accessory set: BASIC kit	Ref.no. 7-125100	page 141

Tacking magnets	Ref.no. 7-1810xx - Ref.no. 7-1814xx	page 146
-----------------	--	----------

Block magnets	Ref.no. 7-184000	page 147
---------------	------------------	----------

Use Legamaster accessories and your board will stay in perfect condition.



PRESENTATION

DYNAMIC felt pinboards



- Design aluminium frame with light grey plastic corner caps
- Specially constructed wall mount provides a stylish "three dimensional" look. The board "floats" in front of the wall
- High quality felt covering
- Available in grey or blue
- Comes complete with fixing kit

Height x Width	Ref.no. Grey felt	Ref.no. Blue felt
60 x 90 cm	7-140343	7-140243
90 x 120 cm	7-140354	7-140254
90 x 180 cm	7-140356	7-140256



PROFESSIONAL lino-cork bulletin pinboards



- Light grey, high quality cork linoleum surface
- Highly versatile and easy to clean with a moist cloth
- Aluminium frame with light grey plastic corner caps
- Can be mounted either horizontally or vertically
- Easy wall mounting with concealed slot system
- Comes complete with fixing kit

Height x Width	Ref.no.
60 x 90 cm	7-140143
90 x 120 cm	7-140154
100 x 150 cm	7-140163
120 x 180 cm	7-140174

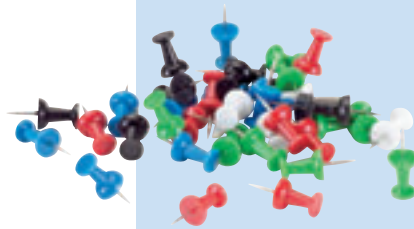

Recommended accessories:
Push-pins in assorted colours Ref.no. 7-1451xx



Lino-cork
bulletin surface

PROFESSIONAL felt pinboards

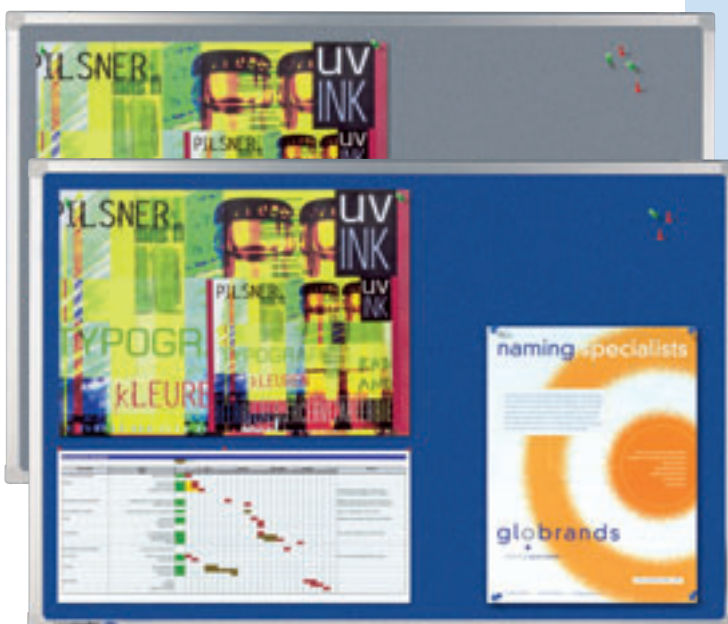

- Durable felt surface
- Aluminium frame with light grey plastic corner caps
- Can be mounted either horizontally or vertically
- Easy wall mounting with concealed slot system
- Comes complete with fixing kit

Height x Width	Ref.no. Grey felt	Ref.no. Blue felt
60 x 90 cm	7-140643	7-140543
90 x 120 cm	7-140654	7-140554
100 x 150 cm	7-140663	7-140563
120 x 180 cm	7-140674	7-140574



Felt surface

PRESENTATION

PREMIUM felt pinboards



- Durable felt surface
- Aluminium frame with offwhite plastic corner caps
- Can be mounted either horizontally or vertically
- Easy wall mounting with concealed slot system
- Comes complete with fixing kit

Height x Width	Ref.no. Grey felt	Ref.no. Blue felt
45 x 60 cm	7-141635	7-141535
60 x 90 cm	7-141643	7-141543
90 x 120 cm	7-141654	7-141554
100 x 150 cm	7-141663	7-141563



 Recommended accessories:
Push-pins in assorted colours Ref.no. 7-1451xx

PREMIUM cork pinboards



- Durable natural cork surface
- Aluminium frame with offwhite plastic corner caps
- Can be mounted either horizontally or vertically
- Easy wall mounting with concealed slot system
- Comes complete with fixing kit

Height x Width	Ref.no.
45 x 60 cm	7-141035
60 x 90 cm	7-141043
90 x 120 cm	7-141054
100 x 150 cm	7-141063

UNIVERSAL felt pinboards



- Felt surface
- Aluminium frame with light grey plastic corner caps
- Can be mounted either horizontally or vertically
- Corner wall mount with corner caps
- Comes complete with fixing materials

Height x Width	Ref.no. Grey felt	Ref.no. Blue felt
45 x 60 cm	7-141935	7-141835*
60 x 90 cm	7-141943	7-141843*
90 x 120 cm	7-141954	7-141854*
100 x 150 cm	7-141963	7-141863

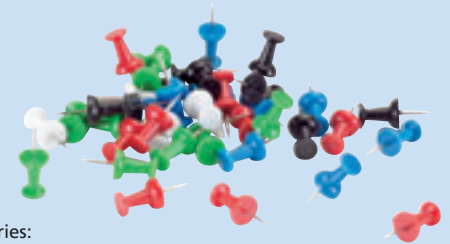

Recommended accessories:
Push-pins in assorted colours Ref.no. 7-1451xx

UNIVERSAL cork pinboards



- Natural cork surface
- Aluminium frame with light grey plastic corner caps
- Can be mounted either horizontally or vertically
- Corner wall mount with corner caps
- Comes complete with fixing materials

Height x Width	Ref.no.
45 x 60 cm	7-142035*
60 x 90 cm	7-142043*
90 x 120 cm	7-142054*
100 x 150 cm	7-142063



* Also available in cash&carry packaging

PRESENTATION

Multiboard mobile



■ Whiteboard



■ Pinboard



■ Flipchart

- For presentation, display and office work
- Multi-purpose: serves as a whiteboard, pinboard and flipchart in one!
- Whiteboard: high quality, scratch resistant enamel surface
- Converts easily into a flipchart by using the removable magnetic pad holder
- Removable magnetic pad holder
- Pinboard on the reverse side of the board
- Space saving, compact design
- Set of castors for mobility
- Can be secured in place; castors are lockable
- Quick and easy to assemble
- Easy to move because of its light-weight construction
- Board: H 120 x W 76 cm
- Total size: H 195 x W 85 cm
- 25 year guarantee is valid for the enamel whiteboard surface
- Comes complete with flipchart paper pad

Colour	Weight	Ref.no.
With navy blue pinboard	approx. 11.6 kg	7-210400
With grey pinboard	approx. 11.6 kg	7-210500



Recommended accessories:
 PROFESSIONAL kit Ref.no. 7-125500
 Push-pins in assorted colours Ref.no. 7-1451xx
 Carry bag Ref.no. 7-230100



Board stand



- Three quick and easy height settings
- Steel frame with a light grey finish
- Two lockable castors
- Distance from board to floor: 61 cm, 71 cm and 81 cm
- Suitable for all Legamaster boards
- Board not included. Please order separately.
Boards assembled on the stands have no marker tray.

Width	Board sizes W to W	Ref.no.
70 cm	90 to 120 cm	7-171100
120 cm	150 to 180 cm	7-171300

Mobile pedestal stand on castors



- Multifunctional, also suitable for the smaller office or conference room
- Sturdy star-base with 5 lockable castors
- Light grey finish
- Height easily adjustable to any setting
- Suitable for all Legamaster boards from H 60 x W 60 cm up to H 60 x W 90 cm
- Base takes up only 65 cm/diameter floor space
- Height adjustable within a 40 cm range
- 15° tilt setting
- Board not included. Please order separately.
Boards assembled on the stands have no marker tray.

Ref.no. 7-170500



*Mobilise your ideas
with an easy-to-use
board stand.*

Tripod easel

- Aluminium tripod stand
- Folds up in seconds; easy to use
- Height adjustable to any setting
- Board clamp for secure grip
- Light weight design for easy mobility
- Suitable for all Legamaster boards (apart from DYNAMIC boards) up to H 90 x W 120 cm
- Weight 2.4 kg
- H 161 x W 97 cm
- Board not included. Please order separately. Boards assembled on the stands have no marker tray.

Ref.no. 7-172300



PRESENTATION

What to consider when buying a flipchart:

1 Base of the flipchart

Would you like a flipchart only for one room?

A tripod will do fine, especially in a corner of the room. If you would like to have a flipchart which can easily be moved, for example to another meeting room, consider using a mobile version!

Limited space for a flipchart?

Look for a mobile flipchart and see the limited floor space these flipcharts require. Easily move your flipchart to another meeting room!

2 Writing surface of your flipchart

How often do you want to use the flipchart?

In case of frequent use we advise to consider the following ergonomic aspects:

- A height adjustable version
- A curved writing surface, which gives your hand support when writing

Would you like to use the flipchart as a whiteboard as well?

Especially the flipcharts with an enamel steel writing surface guarantee you a high quality whiteboard surface.

Would you like to attach cards or other things magnetically to the board?

Look for the feature magnetic board surface.



3 Extra features

Each flipchart has its own design with its own extra features. Take a careful look and make your choice:

- Extendable arms, to hang one or two sheets of paper beside the writing surface. This enlarges the space for information that you can give your audience by two or three times!
- A screw-on pad holder, or preferably, a pad holder which unfolds to hang flipchart pads up in seconds.
- Flexibility to suit all major standard pad formats.



- A height adjustable version



- A pad holder which unfolds to hang flipchart pads up in seconds



- Flexibility to suit all major standard pad formats



- Curved surface
- Extendable side arm

ORION flipchart



- Can also be used as a whiteboard because of its high quality, scratch resistant enamel board surface
- Exceptional, ergonomic design
- Two arms fold out (complete with paper clamps) providing more presentation space for your notes
- Flipchart paper pad is fixed between pad holder and the fold-up marker tray
- Adjustable to suit all major standard paper formats up to 100 x 65 cm
- Markers kept safe in integrated folding marker tray
- Gas-lift for easy height adjustment up to 30 cm
- Round base with 5 castors for mobility (1 lockable)
- Base takes up only 75 cm/diameter floor space
- Plastic parts light grey
- Board height adjustment:
88 to 118 cm (lower edge)
188 to 218 cm (top edge)
- Maximum height 218 cm
- Board size: H 102 x W 67 cm
- Write on / dry wipe surface is guaranteed for 25 years when used in combination with Legamaster accessories
- Comes complete with flipchart paper pad and presentation marker

Colour

Ref.no.

 White (RAL 9016 powder coated)

7-150000

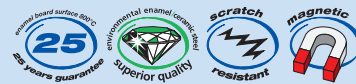

- Ergonomically curved writing surface sets your muscles at rest; supports your hand when writing



- Easily height adjustable
- Flipchart paper pad securely fixed
- Adjustable / rapid changeover
- Marker tray folds up when not in use



- Practical storage of markers



PRESENTATION

TAURUS flipchart



- Can also be used as a whiteboard due to its lacquered steel surface with a special coating
- Exceptional, ergonomic design
- Flipchart paper pad is fixed between pad holder and the fold-up marker tray
- Adjustable to suit all major standard paper formats up to 100 x 65 cm
- Markers kept safe in integrated folding marker tray
- Gas-lift for easy height adjustment up to 30 cm
- Round base with 5 castors for mobility (1 lockable)
- Base takes up only 75 cm/diameter floor space
- Plastic parts light grey for white and white aluminium and dark grey transparent for anthracite
- Board height adjustment:
88 to 118 cm (lower edge)
188 to 218 cm (top edge)
- Maximum height 218 cm
- Board size: H 102 x W 67 cm
- Comes complete with flipchart paper pad and presentation marker

Colour	Ref.no.
White (RAL 9016 powder coated)	7-150200
White aluminium (RAL 9006 powder coated)	7-150202
Anthracite (textured powder coating)	7-150201



- Ergonomically curved writing surface sets your muscles at rest; supports your hand when writing



- Easily height adjustable
- Flipchart paper pad securely fixed, adjustable / rapid changeover
- Marker tray folds up when not in use
- Practical storage of markers



SILVERTEC mobile flipchart



- Metal flipchart with a high quality silver coloured coating
- Curved surface, ergonomic design
- Suitable for paper roll and also adjustable to suit all major standard paper pad formats
- Star base and five lockable castors ensure easy mobility
- One integrated extendable side arm, magnetic; can be used on the left or the right
- Easily height adjustable
- Paper clamp with integrated marker tray
- Base takes up only 70 cm/diameter floor space
- Height adjustable from approx. 170 cm to 210 cm
- Weight: 21.5 kg
- Board size: H 103 x W 70 cm
- Comes complete with paper roll (35 m) and presentation marker

Colour	Ref.no.
 Silver coloured coating	7-151000



Recommended accessory:
Paper roll Ref.no. 7-156900

Keep writing - Simply extend your writing area by pulling the 35 m paper roll.

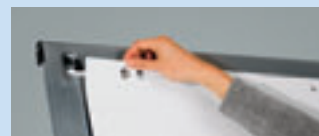

PRESENTATION

IMAGINE COLOUR flipchart



- A distinctive flipchart with clear lines and exquisite attention to detail by using a subtle colour label strip in the frame
- The IMAGINE flipchart is part of the IMAGINE product family. The IMAGINE family also exists of a whiteboard
- Anodised aluminium frame with a high quality, scratch resistant enamel board surface
- Mobile base with 5 lockable castors
- Base takes up only 70 cm/diameter floor space
- Easily height adjustable
- Pad holder unfolds to hang flipchart paper pad up in seconds
- Adjustable to suit all major standard paper pad formats
- Delivered with a classic blue label strip (standard); with the option of different exchangeable solid and transparent colours
- Comes complete with strip, integrated minimalistic marker tray, paper pad and presentation marker
- Modern stylish marker tray ("swoosh") including matching colour label, to be ordered separately

Colour	Ref.no.
Classic blue	7-150300

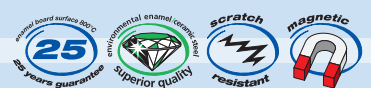

- All IMAGINE COLOUR family members, standard in classic blue, have the possibility to easily exchange the colour labels and the "swoosh" (modern stylish marker tray)
- Exchange only the colour label or choose a swoosh with matching label strip for the flipchart. On request it is possible to print the label in your corporate identity with your own logo

Length label + swoosh	Ref.no.
70 cm	7-1256xx add colour code



Set of 8 different colour labels assorted 120 cm, to fit flipcharts width 70 cm
Ref.no. 7-126600

PROFESSIONAL flipchart tripod



- Can also be used as a whiteboard because of its high quality, scratch resistant enamel board surface
- Functional, solid, secure
- Height adjustable to any setting
- Adjustable to suit all major standard paper pad formats
- Spring-loaded paper clamp
- Paper clamp with useful tear-off edge
- Practical marker tray
- Aluminium frame with grey plastic corner caps
- Flipchart legs made of chrome-plated steel
- Board size: H 107 x W 71 cm
- Weight: 13 kg
- Maximum height: 179 cm, height adjustable to any setting
- Floor space: W 84 x D 110 cm
- Write on / dry wipe surface is guaranteed for 25 years when used in combination with Legamaster accessories
- Comes complete with flipchart paper pad and presentation marker

Ref.no. 7-152000

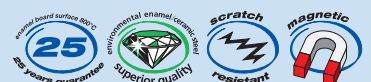

Flipcharts Triangle

A triangle is the simplest geometric figure and is favoured in structures.

The triangle has the advantage that it will not change shape when the lengths of the sides are fixed. Because it is not easily deformed, the triangle is an extremely popular building shape. A famous example is the Eiffel tower.

The triangle shape is at the basis of the newly designed flipchart range. You will find it in the base of the tripods, as well as in the many elements of the construction.



The Triangle range of flipcharts offers stability, solidity and an attractive design at the same time!



PRESENTATION

PROFESSIONAL / PREMIUM flipchart Triangle mobile



- Attractive high-end design flipchart
- Solid and robust construction, including robust board side profiles for easy handling and a firm (ergonomic) hold
- Magnetic, notes can be stuck to the board with magnets
- Writeable/dry-wipeable board surface, suitable for writing on with board markers
- Solid 5-star-base for stability, including 2 lockable castors
- Unique 5-star foot design; foot parts are covered with stylish perforated steel foot cover plates
- Full width robust flip-down marker tray, to store a range of whiteboard markers
- Concealed marker storage, marker tray can be flipped up after storing markers
- Including two pull-out extendable side arms, magnetic, from which papers can be hung, giving you more space to present your notes
- Robust flip-up paper clamp for quick and easy change of flipchart paper pads
- Movable paper hooks for flipchart paper pad; adjustable to suit all major standard paper pad formats
- Easy, infinitely variable height adjustment; can easily be set at ideal writing level

- Flipchart board size: H 105 x W 68 cm
- Weight: 15.5 kg
- Max. height: 205 cm
- Floor space: W 72 x D 60 cm
- All dark coloured parts RAL 7024
- Base in RAL 7024; black castors

PROFESSIONAL flipchart Triangle

This is a flipchart with a high quality, scratch resistant enamel steel board surface!

For this type of board surface write on / dry wipe surface is guaranteed for 25 years when used in combination with Legamaster accessories.

Flipchart	Board surface	Ref.no.
PROFESSIONAL Triangle mobile	Enamel steel	7-153500



PREMIUM flipchart Triangle

This flipchart has a lacquered steel board surface.

For this type of board surface write on / dry wipe surface is guaranteed for 5 years when used in combination with Legamaster accessories.

Flipchart	Board surface	Ref.no.
PREMIUM Triangle mobile	Lacquered steel	7-153400



PROFESSIONAL / PREMIUM flipchart Triangle tripod



- Attractive high-end design flipchart
- Solid and robust construction, including robust board side profiles for easy handling and a firm (ergonomic) hold
- Magnetic, notes can be stuck to the board with magnets
- Writeable/dry-wipeable board surface, suitable for writing on with board markers
- Unique fold-away tripod foot design
- Particularly useful when storing the flipchart against a wall or in a corner
- Full width robust flip-down marker tray, to store a range of whiteboard markers
- Concealed marker storage, marker tray can be flipped up after storing markers
- Including two pull-out extendable side arms, magnetic, from which papers can be hung, giving you more space to present your notes
- Robust flip-up paper clamp for quick and easy change of flipchart paper pads
- Movable paper hooks for flipchart paper pad; adjustable to suit all major standard paper pad formats
- Easy, infinitely variable height adjustment; can easily be set at ideal writing level

- Flipchart board size: H 105 x W 68 cm
- Weight: 16 kg
- Max. height: 205 cm
- Floor space: W 72 x D 50 cm
- All dark coloured parts RAL 7024
- Fold-away base partly covered with steel perforated foot plates

PROFESSIONAL flipchart Triangle

This is a flipchart with a high quality, scratch resistant enamel steel board surface!

For this type of board surface write on / dry wipe surface is guaranteed for 25 years when used in combination with Legamaster accessories.

Flipchart	Board surface	Ref.no.
PROFESSIONAL Triangle tripod	Enamel steel	7-153100



PREMIUM flipchart Triangle

This flipchart has a lacquered steel board surface.

For this type of board surface write on / dry wipe surface is guaranteed for 5 years when used in combination with Legamaster accessories.

Flipchart	Board surface	Ref.no.
PREMIUM Triangle tripod	Lacquered steel	7-153000



Recommended accessory:
Presentation marker TZ 41
Ref.no. 7-1550xx

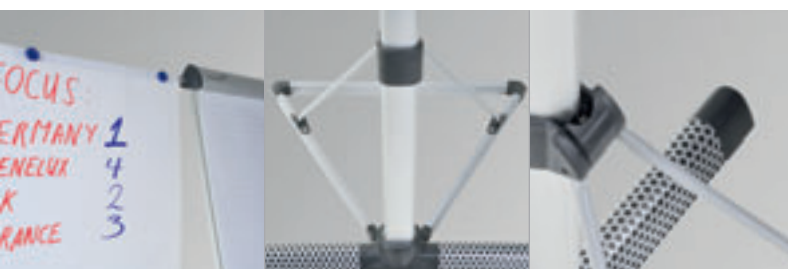

PRESENTATION

UNIVERSAL flipchart Triangle mobile and Triangle tripod



- Attractive flipchart
- Lacquered steel board surface
- Magnetic, notes can be stuck to the board with magnets
- Writeable/dry-wipeable board surface, suitable for writing on with board markers
- Full width marker tray, to store a range of whiteboard markers
- Including two pull-out extendable side arms, magnetic, from which papers can be hung, giving you more space to present your notes
- Robust flip-up paper clamp for quick and easy changeover of flipchart paper pads
- Movable paper hooks for flipchart paper pad; adjustable to suit all major standard paper pad formats
- Easy, infinitely variable height adjustment; can easily be set at ideal writing level

UNIVERSAL flipchart Triangle mobile

- Solid 5-star-base for stability, including 2 lockable castors
- Flipchart board size: H 105 x W 68 cm
- Weight: 13 kg
- Max. height: 205 cm
- Floor space: W 72 x D 60 cm
- All dark coloured parts RAL 7024
- Base in RAL 7024; black castors

UNIVERSAL flipchart Triangle tripod

- Third flipchart leg is secured in the back; it can not slide away when there is pressure on the board while writing
- Flipchart board size: H 105 x W 68 cm
- Weight: 11.5 kg
- Max. height: 187 cm
- Floor space: W 79 x D 74 cm
- All dark coloured parts RAL 7024
- Tripod legs in RAL 9006 (white aluminium)

Flipchart	Board surface	Ref.no.
UNIVERSAL Triangle mobile	Lacquered steel	7-153300
UNIVERSAL Triangle tripod	Lacquered steel	7-152900



Recommended accessory:
Presentation marker TZ 41
Ref.no. 7-1550xx



ECONOMY flipchart Triangle mobile and Triangle tripod



- Lacquered steel board surface
- Magnetic, notes can be stuck to the board with magnets
- Writeable/dry-wipeable board surface, suitable for writing on with board markers
- Flip-up paper clamp for quick and easy changeover of flipchart paper pads
- Integrated small finger grip guarantees a user-friendly paper clamp
- Movable paper hooks for flipchart paper pad; adjustable to suit all major standard paper pad formats
- Full width pen tray, to store a range of whiteboard markers
- Simplicity: easy set-up

ECONOMY flipchart Triangle mobile

- Solid 5-star-base for stability, including 2 lockable castors
- Flipchart board size: H 105 x W 68 cm
- Floor space: W 72 x D 60 cm
- All dark coloured parts RAL 7024
- Base in RAL 7024; black castors

ECONOMY flipchart Triangle tripod

- Easy, infinitely variable height adjustment; can easily be set at ideal writing level
- Third flipchart leg is secured at the back; it cannot slide away when there is pressure on the board while writing
- Flipchart board size: H 105 x W 68 cm
- Floor space: W 79 x D 74 cm
- All dark coloured parts RAL 7024
- Tripod legs in RAL 9006 (white aluminium)

Flipchart	Weight	Height	Ref.no.
ECONOMY Triangle mobile	12.5 kg	190 cm	7-153200
ECONOMY Triangle tripod	10.5 kg	187 cm	7-152800



BASIC flipchart Triangle tripod



- Melamine resin board surface (non-magnetic)
- Writeable/dry-wipeable board surface, suitable for writing on with board markers
- Flip-up paper clamp for quick and easy changeover of flipchart paper pads
- Integrated small finger grip guarantees a user friendly paper clamp
- Movable paper hooks for flipchart paper pad; adjustable to suit all major standard paper pad formats
- Full width pen tray, to store a range of whiteboard markers
- Easy, infinitely variable height adjustment; can easily be set at ideal writing level
- Third flipchart leg is secured at the back; it cannot slide away when there is pressure on the board while writing
- Simplicity: easy set-up
- Flipchart board size: H 105 x W 68 cm
- Floor space: W 79 x D 74 cm
- All dark coloured parts RAL 7024
- Tripod legs in RAL 9006 (white aluminium)



Flipchart	Weight	Max. Height	Ref.no.
BASIC Triangle tripod	9 kg	187 cm	7-152700

PRESENTATION



Flipchart accessory STARTER kit

- A practical all-in-one accessory set for your flipchart
- Includes paper as well as accessories
- Includes a free small booklet with "tips and tricks" on:
 - how to use the accessories best in combination with your flipchart
 - how to use flipchart paper efficiently
 - how to write clear and clean on paper charts with our special Legamaster markers
 - and much more!

- Contents:
 - 3 flipchart paper pads 20 sheets plain
 - set of 2 presentation markers TZ 48 (one of each colour: black, red)
 - set of 4 presentation markers TZ 41 (one of each colour: black, red, blue, green)
 - 4 magnets 30 mm
 - 1 free booklet with tips and tricks



Ref.no. 7-124900

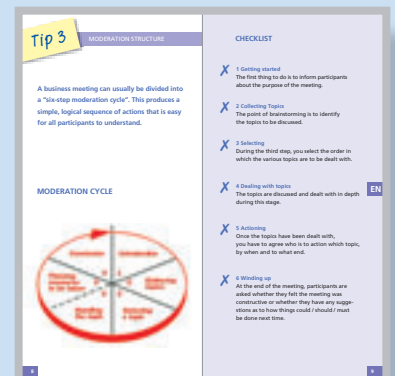
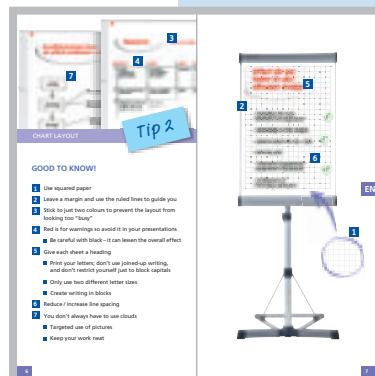
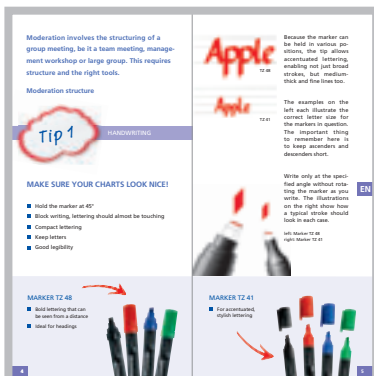
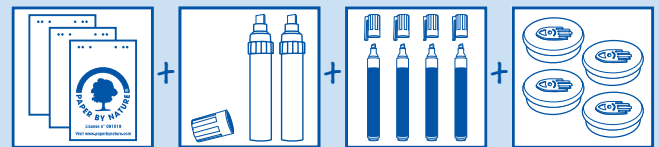

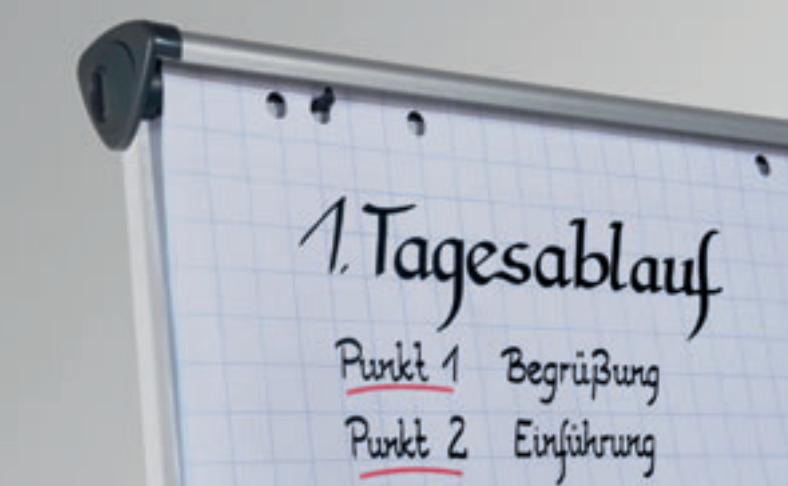

Flipchart paper

- 20-sheet paper pads
- Wood-free, white paper
- Pack of 5 pads
- Perforations enable individual sheets to be torn off easily
- Sheet size: 98 x 65 cm
- 80 gsm
- Chlorine-free, bleached paper



Sheet	Grid size	Ref.no.
Plain	-	7-156000
Grid	2.5 x 2.5 cm	7-156500



Paper roll for SILVERTEC mobile

- Paper roll for SILVERTEC mobile flipchart
- 35 m roll
- Wood-free, white paper
- 80 gsm
- Chlorine-free, bleached paper

Ref.no. 7-156900



Flipchart accessories



Presentation marker TZ 41 Ref.no. 7-1550xx page 142

Presentation marker JUMBO TZ 48 Ref.no. 7-1555xx page 142

Refill ink for presentation markers TZ 41 Ref.no. 7-1558xx page 142

Refill ink for presentation markers TZ 48 Ref.no. 7-1559xx page 142

Tacking magnets Ref.no. 7-1810xx - Ref.no. 7-1814xx page 146

PRESENTATION

Magic-Chart

- Ready to use solution for every spontaneous or planned meeting
- Creates an instant writing surface, even when a whiteboard or flipchart are not available
- Electrostatic foil easily sticks to almost any surface (wood, concrete, glass, wallpaper)
- Long lasting electrostatic product properties (up to 5 years!)
- No adhesive required, leaves no traces
- Sheets can be repositioned easily
- Presentation cards and notices will stick without help simply by smoothing them onto the foil
- Environmentally friendly: fully recyclable
- 25 sheets
- Roll width 60 cm, perforations every 80 cm
- Including marker

Ready-to-use large writing sheets for any meeting, spontaneous or planned.



Magic-Chart whiteboard

- Fully white Magic-Chart foil (whiteboard effect)
- Glossy look
- Can be written on using Legamaster board markers and edding permanent markers
- Permanent markers guarantee a more intensive ink colour (longer drying time)
- Erasable when used in combination with Legamaster board markers
- Environmentally friendly: one sheet can be used up to 10 times!



Magic-Chart flipchart



- Fully gridded Magic-Chart foil (flipchart effect)
- Grid size 2.5 x 2.5 cm
- Can be written on using Legamaster board markers and edding permanent markers



Magic-Chart blackboard

- Fully black Magic-Chart foil (black chalkboard effect)
- Can be used:
 - to black out/darken windows
 - to darken a room in case bright sun light makes it difficult to give a beamer presentation
 - to create a chalk board effect; e.g. present a restaurant menu in an original way
- Can be written on using:
 - edding neon board markers
 - edding paint markers
- Highest electrostatic properties



Magic-Chart	Grid size	Ref.no.	
	Magic-Chart whiteboard	-	7-159100
	Magic-Chart blackboard	-	7-159200
	Magic-Chart flipchart	2.5 x 2.5 cm	7-159000



Produced in an environmentally friendly way and completely recyclable

MODERATION

Conducting successful meetings and brainstorming sessions is an art in itself and, unfortunately, in many instances the participant's involvement is often passive. The Legamaster workshop method offers a solution that allows all participants to take an active part in the discussion.

The moderation products offered by Legamaster make communication clear and creative. With moderation boards, cases and accessories, it is easy to create an interesting environment for participants.



Moderation involves the structuring of a group meeting, be it a team meeting, management workshop or large group. This requires structure and the right tools.

Moderation structure

A business meeting can usually be divided into a "six-step moderation cycle". This produces a simple, logical sequence of actions that is easy for all participants to understand.

- 1 Getting started**
The first thing to do is to inform participants about the purpose of the meeting.
- 2 Collecting Topics**
The point of brainstorming is to identify the topics to be discussed.
- 3 Selecting**
During the third step, you select the order in which the various topics are to be dealt with.
- 4 Dealing with topics**
The topics are discussed and dealt with in depth during this stage.
- 5 Actioning**
Once the topics have been dealt with, you have to agree who is to action which topic, by when and to what end.
- 6 Winding up**
At the end of the meeting, participants are asked whether they felt the meeting was constructive or whether they have any suggestions as to how things could / should / must be done next time.

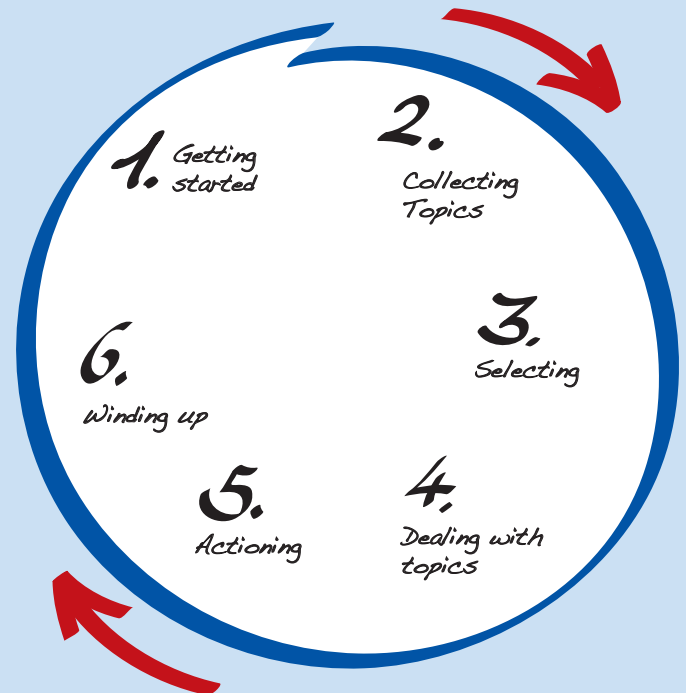

Josef W. Seifert,
Moderator & Moderation trainer,
author of successful books on moderation,
managing partner of the consultancy and
training company MODERATIO®

Plan first, then act!

If you are wondering whether to hold an improvised meeting or prepare for it in advance, you may find the first option appealing, but the second is better!

The trick of successful business moderation is to approach a moderation exercise as a mini project, this will involve dividing the overall work process into sensible chunks (units).

So at the very least, you should draw up a brief MODERATION plan which sets out the objective for each of the six moderation steps, and the procedure or method you will be using to moderate or guide the group during each particular stage. You can then work consistently with the group using your plan.



"A moderation process will invariably involve the use of Legamaster products! This is because professional performance can only be achieved with professional equipment; every professional knows this – from the tradesman to the musician, from the project leader to the moderator/facilitator!"

MODERATION

PROFESSIONAL Travel moderation board

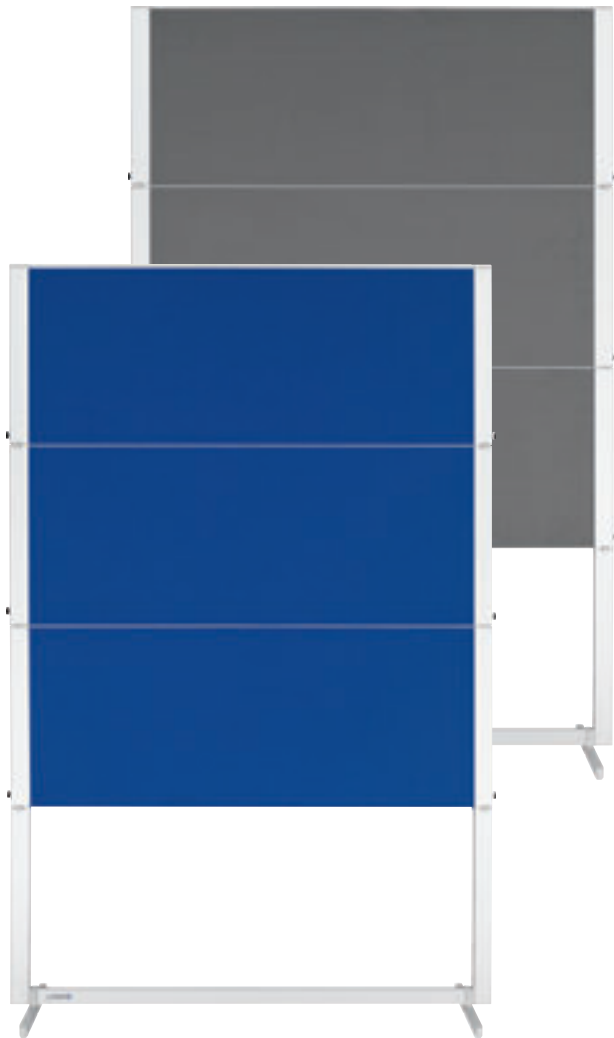

- Space-saving unique folding design moderation board
- Double-sided felt covering
- Folds into 4 sections, the perfect solution for flexibility and easy transportation
- Light-weight design for easy mobility
- Easy to set up by one person
- Folded board will fit into any car for transportation
- Foldable foot allows for arranging board in a straight line or in a semi-circle
- Board size: approx. H 150 x W 120 cm
- Height of the total product: ca. 195 cm
- Dimensions folded: L 1290 x W 110 x H 515 mm

Colour	Weight	Ref.no.
Dark blue	approx. 10 kg	7-203400
Grey	approx. 10 kg	7-203500



Recommended accessories:
Moderation case:
PROFESSIONAL Travel Ref.no. 7-221000



- Folds into 4 sections
- Foldable foot

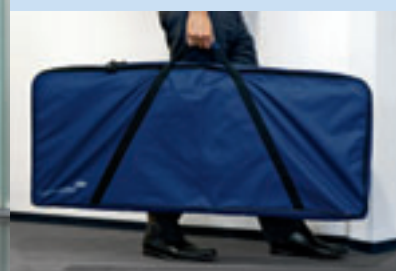

- Comes complete with carry bag

PROFESSIONAL Mobile moderation board



- High-end design board for modern offices and training surroundings
- High-quality aluminium design frame
- Double-sided felt covering
- Light-weight for mobile use
- Quick assembly
- Foldable foot with 4 lockable castors, allows for arranging board in a straight line or in a semi-circle
- Board size: approx. H 150 x W 120 cm
- Height of the total product ca. 195 cm

Colour	Weight	Ref.no.
Dark blue	approx. 9 kg	7-202400
Grey	approx. 9 kg	7-202500



Recommended accessories:
Moderation case:
PROFESSIONAL Ref.no. 7-221100



MODERATION

PREMIUM Mobile moderation board



- For effective, targeted teamwork
- For moderation technique, or your choice of use
- Double-sided felt covering or plain foam board
- Very easy to insert pins; pins can be used on both sides
- Fast, simple assembly
- Attractive, light-weight design, aluminium framed
- Set of 4 castors for mobility
- Can be secured in place; castors are lockable
- Board size: H 150 x W 120 cm
- 15 mm rigid foam core construction
- Height: 195 cm (including castors)

Colour	Weight	Ref.no.
White/plain foam board	approx. 7.2 kg	7-204000
Beige/felt covering	approx. 7.9 kg	7-204100
Blue-grey/felt covering	approx. 7.9 kg	7-204200
Navy blue/felt covering	approx. 7.9 kg	7-204400
Grey/felt covering	approx. 7.9 kg	7-204500



Recommended accessories:
Moderation case:
PREMIUM Ref.no. 7-221200

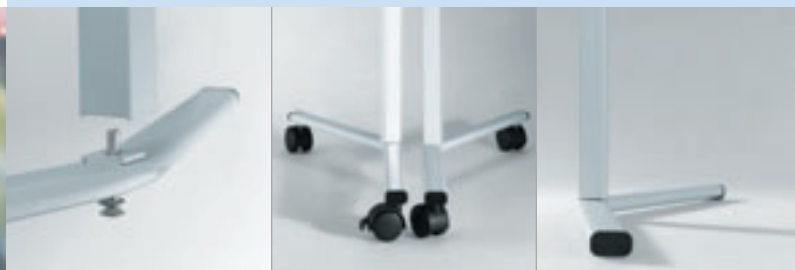





- Legs connect securely to the feet
- Comes complete with lockable castors
- Integrated runners when used without castors

PREMIUM Folding mobile moderation board



- Hinge mechanism for speedy folding / unfolding
- For effective, targeted teamwork
- Double-sided felt covering or plain foam board
- Very easy to insert pins; pins can be used on both sides
- Fast, simple assembly
- Attractive, light-weight design, aluminium framed
- Set of 4 castors for mobility
- Can be secured in place; castors are lockable
- Board size H 150 x W 120 cm
- 15 mm rigid foam core construction
- Height: 195 cm (including castors)
- Height when folded: 120 cm (including castors)

Colour	Weight	Ref.no.
	White/plain foam board approx. 7.4 kg	7-205000
	Beige/felt covering approx. 8.1 kg	7-205100
	Blue-grey/felt covering approx. 8.1 kg	7-205200
	Navy blue/felt covering approx. 8.1 kg	7-205400
	Grey/felt covering approx. 8.1 kg	7-205500



Recommended accessories:
Moderation case:
PREMIUM Ref.no. 7-221200
Transportable using carry bag
Ref.no. 7-230100





- Board folds / unfolds quickly
- Super fast assembly
- Practical slot-in connection

ECONOMY moderation board



- Foldable; stable mechanism for folding / unfolding
- Double-sided felt covering
- Comes with instructions for quick and easy assembly
- Secure and stable board; footing and legs in one construction
- Legs firmly attached to the board
- White powder coated aluminium board frame; footing and legs in white powder coated steel (RAL 9016)
- Board size: H 150 x W 120 cm
- Height of the total product: 194 cm

Colour	Weight	Ref.no.
	White/plain foam board approx. 5.5 kg	7-207200
	Blue/felt covering approx. 5.5 kg	7-207100
	Grey/felt covering approx. 5.5 kg	7-207000



Recommended accessories:
Moderation case:
BASIC Ref.no. 7-220900
Transportable using carry bag
Ref.no. 7-230100



MODERATION

Multiboard mobile



- For presentation, display and office work
- Multi-purpose: serves as a whiteboard, pinboard and flipchart in one!
- Whiteboard: high quality, scratch resistant enamel surface
- Converts easily into a flipchart by using the removable magnetic pad holder
- Removable magnetic pad holder
- Pinboard on the reverse side of the board
- Space saving, compact design
- Set of castors for mobility
- Can be secured in place; castors are lockable
- Quick and easy to assemble
- Easy to move because of its light-weight construction
- Board: H 120 x W 76 cm
- Total size: H 195 x W 85 cm
- 25 year guarantee is valid for the enamel whiteboard surface
- Comes complete with flipchart paper pad

Colour	Weight	Ref.no.
With navy blue pinboard	approx. 11.6 kg	7-210400
With grey pinboard	approx. 11.6 kg	7-210500



Recommended accessories:
 PROFESSIONAL kit Ref.no. 7-125500
 Push-pins in assorted colours Ref.no. 7-1451xx
 Carry bag Ref.no. 7-230100



Carry bag



- Ideal for travel or for storage
- Suitable for PREMIUM and ECONOMY folding boards and Multiboard mobile
- Safe way to carry moderation boards or multiboards
- Suitable for up to two folding moderation boards or one moderation board and one multiboard
- Dark blue non-rip nylon fabric
- Extra pockets for your documents
- Durable shoulder strap included
- H 134 x W 80 x D 12 cm
- Weight 1.8 kg

Ref.no. 7-230100



PROFESSIONAL Travel moderation case



- High-end design case for portable use
- Including trolley for easy transportation and travelling
- Mobile; always at hand
- Fully equipped for all presentation, moderation and brainstorming sessions
- All items are packed in an organised way
- Scratch resistant case with ABS / Aluminium materials
- Dimensions: approx. W 40 x H 52 x D 19 cm
- Weight excluding contents: approx. 5.5 kg
- Weight including contents: approx. 10 kg
- Contains:
 - 20 clouds, 26 x 41 cm · 100 strips for headlines, assorted colours · 500 rectangles, 10 x 20 cm, assorted colours · 250 ovals, 11 x 20 cm, assorted colours · 250 circles, diam. 10 cm, assorted colours · 250 circles, diam. 14 cm, assorted colours · 100 circles, diam. 19 cm, assorted colours · 1040 stickers, 19 mm diam.: 520 red, 520 blue · 30 presentation markers TZ 41: 15 black, 15 red · 4 jumbo presentation markers TZ 48: 1 black, 1 red, 1 blue, 1 green · 2 bottles of refill ink for presentation markers: 1 black, 1 red · 400 marker pins, 100 each in red, blue, yellow and green · 1 clip-on pin cushion · 1 x 8-inch pair of scissors · 1 cutter · 1 roll of drafting tape · 1 tape dispenser · 2 glue sticks · 1 telescopic pointer

Ref.no. 7-221000

PROFESSIONAL moderation case



- High-end design case for portable use
- Fully equipped for all presentation, moderation and brainstorming sessions
- All items are packed in an organised way
- Scratch resistant case with ABS / Aluminium materials
- Dimensions: approx. W 40 x H 52 x D 15 cm
- Weight excluding contents: approx. 3.5 kg
- Weight including contents: approx. 8 kg
- Contains:
 - 20 clouds, 26 x 41 cm · 100 strips for headlines, assorted colours · 500 rectangles, 10 x 20 cm, assorted colours · 250 ovals, 11 x 20 cm, assorted colours · 250 circles, diam. 10 cm, assorted colours · 250 circles, diam. 14 cm, assorted colours · 100 circles, diam. 19 cm, assorted colours · 1040 stickers, 19 mm diam.: 520 red, 520 blue · 30 presentation markers TZ 41: 15 black, 15 red · 4 jumbo presentation markers TZ 48: 1 black, 1 red, 1 blue, 1 green · 2 bottles of refill ink for presentation markers: 1 black, 1 red · 400 marker pins, 100 each in red, blue, yellow and green · 1 clip-on pin cushion · 1 x 8-inch pair of scissors · 1 cutter · 1 roll of drafting tape · 1 tape dispenser · 2 glue sticks · 1 telescopic pointer

Ref.no. 7-221100

MODERATION

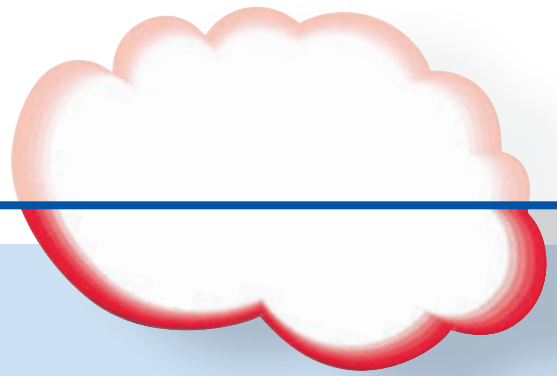

PREMIUM moderation case



- High-end design case for portable use
- Comes complete with moderation accessories
- All items are packed in an organised way
- Scratch resistant case with ABS / Aluminium materials
- Dimensions: approx. W 33 x H 47 x D 13 cm
- Weight excluding contents: approx. 2 kg
- Weight including contents: approx. 5 kg
- Contains:
 - 10 clouds, 26 x 41 cm · 500 rectangles, 10 x 20 cm, assorted colours · 100 ovals, 11 x 20 cm, assorted colours · 100 circles, diam. 10 cm, assorted colours · 100 circles, diam. 14 cm, assorted colours · 100 circles, diam. 19 cm, assorted colours · 1040 stickers, 19 mm diam.: 520 red, 520 blue · 24 presentation markers TZ 41: 12 black, 12 red · 4 jumbo presentation markers TZ 48: 1 black, 1 red, 1 blue, 1 green · 200 marker pins: 100 each in red and blue · 1 clip-on pin cushion · 1 x 8-inch pair of scissors · 1 roll of drafting tape · 1 glue stick

Ref.no. 7-221200

MOBILE moderation unit



- The all-inclusive mobile presenter unit
- Mobile; always at hand. No unnecessary walking around, no silent pauses
- 4 legs with castors for mobility
- No need for additional table to store your materials
- Quick to assemble
- Modern aluminium design
- Handy sections are clearly partitioned
- Robust aluminium framed case
- Size: W 54 x H 16 x D 51 cm
- Weight when full: approx. 12.4 kg
- Height of unit when fully assembled: 60 cm
- Contains:
 - 20 clouds, 26 x 41 cm · 100 strips for headlines, assorted colours · 500 rectangles, 10 x 20 cm, assorted colours · 250 ovals, 11 x 20 cm, assorted colours · 250 circles, diam. 10 cm, assorted colours · 250 circles, diam. 14 cm, assorted colours · 100 circles, diam. 19 cm, assorted colours · 1040 stickers, 19 mm diam.: 520 red, 520 blue · 30 presentation markers TZ 41: 15 black, 15 red · 4 jumbo presentation markers TZ 48: 1 black, 1 red, 1 blue, 1 green · 2 bottles of refill ink for presentation markers: 1 black, 1 red · 400 marker pins, 100 each in red, blue, yellow and green · 1 clip-on pin cushion · 1 x 8-inch pair of scissors · 1 cutter · 1 roll of drafting tape · 1 tape dispenser · 2 glue sticks · 1 telescopic pointer

Ref.no. 7-220100



COMFORT moderation case



- Fully equipped for all presentations, moderation, brainstorming, etc
- Fold-down flap inside lid reveals space for transparencies, pens, notes and other accessories
- Modern aluminium design
- Handy sections are clearly partitioned
- Robust aluminium framed case
- Size: W 54 x H 16 x D 35 cm
- Weight when full: approx. 9.5 kg
- Contains:
 - 20 clouds, 26 x 41 cm · 100 strips for headlines, assorted colours · 500 rectangles, 10 x 20 cm, assorted colours · 250 ovals, 11 x 20 cm, assorted colours · 250 circles, diam. 10 cm, assorted colours · 250 circles, diam. 14 cm, assorted colours · 100 circles, diam. 19 cm, assorted colours · 1040 stickers, 19 mm diam.: 520 red, 520 blue · 30 presentation markers TZ 41: 15 black, 15 red · 4 jumbo presentation markers TZ 48: 1 black, 1 red, 1 blue, 1 green · 2 bottles of refill ink for presentation markers: 1 black, 1 red · 400 marker pins, 100 each in red, blue, yellow and green · 1 clip-on pin cushion · 1 x 8-inch pair of scissors · 1 cutter · 1 roll of drafting tape · 1 tape dispenser · 2 glue sticks · 1 telescopic pointer

Ref.no. 7-220300



TRAVEL moderation case



- Practical for travel
- Useful for company meetings
- Compact size / light-weight
- Comes complete with accessories
- Adjustable partitioning to suit individual needs
- Modern aluminium design
- Handy sections are clearly partitioned
- Robust aluminium frame
- Size: W 43 x H 12 x D 32 cm
- Weight when full: 5.9 kg
- Contains:
 - 10 clouds, 26 x 41 cm · 500 rectangles, 10 x 20 cm, assorted colours · 100 ovals, 11 x 20 cm, assorted colours · 100 circles, diam. 10 cm, assorted colours · 100 circles, diam. 14 cm, assorted colours · 100 circles, diam. 19 cm, assorted colours · 1040 stickers, 19 mm diam.: 520 red, 520 blue · 24 presentation markers TZ 41: 12 black, 12 red · 4 jumbo presentation markers TZ 48: 1 black, 1 red, 1 blue, 1 green · 200 marker pins: 100 each in red and blue · 1 clip-on pin cushion · 1 x 8-inch pair of scissors · 1 roll of drafting tape · 1 glue stick

Ref.no. 7-220500



MODERATION

PRACTIC moderation case



- Handy presentation aid
- Practical: contains basic accessories for presentation
- Modern design case
- Handy sections are clearly partitioned
- Solid plastic hard-shell case
- Size: W 35 x H 13 x D 33 cm
- Weight (including contents) approx. 3.4 kg
- Contains:
 - 500 rectangles, 10 x 20 cm, assorted colours · 100 ovals, 11 x 20 cm, assorted colours · 100 circles, diam. 14 cm, assorted colours · 16 presentation markers TZ 41: 8 black, 8 red · 2 Jumbo presentation markers TZ 48: 1 black, 1 red · 100 pins, blue · 1 glue stick

Ref.no. 7-220700



BASIC moderation case



- Starter moderation case
- High quality accessories
- Practical case design: suitcase lid stays up automatically
- Handy sections are clearly partitioned
- Plastic housing with plastic in-lays for positioning the content
- Sizes: W 33.5 x H 28.5 x D 7.5 cm
- Contains:
 - 250 rectangles, 10 x 20 cm, ass. colours · 100 ovals, 11 x 20 cm, assorted colours · 100 circles, diam. 14 cm, assorted colours · 10 presentation markers TZ 41: 5 black, 5 red · 2 jumbo presentation markers TZ 48: 1 black, 1 red · 200 push pins · 1 UHU stick

Ref.no. 7-220900



MODERATION kit



- For team meetings / hotel conferences, etc.
- Sturdy box with carry handle
- Can also be used as a refill kit for presentation cases
- Dimensions: approx. W 38 x H 23.5 x D 12.5 cm
- Contains:
 - 10 clouds, small · 500 rectangles, 10 x 20 cm, five assorted colours ·
 - 100 ovals, white, 11 x 20 cm · 100 circles, white, diam. 10 cm ·
 - 100 circles, white, diam. 14 cm · 50 circles, white, diam. 19 cm ·
 - 50 strips, pink · 480 stickers: 240 in blue, 240 in red · 20 presentation markers TZ 41: 10 red, 10 black · 4 jumbo presentation markers TZ 48: 1 black, 1 red, 1 blue, 1 green · 1 glue stick · 200 pins (100 red, 100 blue)



Ref.no. 7-225000



Moderation paper



- 80 gsm
- Sheet size: 116 x 140 cm
- Brown, subtly lined to aid writing or white, chlorine-free bleached paper
- 100 sheet pack

Colour	Ref.no.
	Brown 7-240100
	White 7-240300



MODERATION



Magic-Chart

- Ready to use solution for every spontaneous or planned meeting
- Creates an instant writing surface, even when a whiteboard or flipchart are not available
- Electrostatic foil easily sticks to almost any surface (wood, concrete, glass, wallpaper)
- Long lasting electrostatic product properties (up to 5 years!)
- No adhesive required, leaves no traces
- Sheets can be repositioned easily
- Presentation cards and notices will stick without help simply by smoothing them onto the foil
- Environmentally friendly: fully recyclable
- 25 sheets
- Roll width 60 cm, perforations every 80 cm
- Including marker

Magic-Chart	Grid size	Ref.no.
Magic-Chart whiteboard	–	7-159100
Magic-Chart blackboard	–	7-159200
Magic-Chart flipchart	2.5 x 2.5 cm	7-159000

Magic-Chart whiteboard

- Fully white Magic-Chart foil (whiteboard effect)
- Glossy look
- Can be written on using Legamaster board markers and edding permanent markers
- Permanent markers guarantee a more intensive ink colour (longer drying time)
- Erasable when used in combination with Legamaster board markers
- Environmentally friendly: one sheet can be used up to 10 times!



Produced in an environmentally friendly way and completely recyclable

Magic-Chart flipchart

- Fully gridded Magic-Chart foil (flipchart effect)
- Grid size 2.5 x 2.5 cm
- Can be written on using Legamaster board markers and edding permanent markers



Magic-Chart blackboard

- Fully black Magic-Chart foil (black chalkboard effect)
- Can be used:
 - to black out/darken windows
 - to darken a room in case bright sun light makes it difficult to give a beamer presentation
 - to create a chalk board effect; e.g. present a restaurant menu in an original way
- Can be written on using:
 - edding neon board markers
 - edding paint markers
- Highest electrostatic properties

Ready-to-use large writing sheets for any meeting, spontaneous or planned.



Moderation cards

Mini clouds:
emphasize comments and statements

Clouds:
for bold display of the main session theme; give visual prominence to results

Rectangles:
for statements from the audience: particularly good for question and answer sessions

Circles 9.5 cm diam.:
For numbering comments or placing them in order

Circles 14 and 19 cm diam.:
Emphasise specific statements or ideas, name groups or related areas

Ovals:
Describe emotional statements / characterise clusters; can be used as alternative to rectangles

Strips:
For writing questions and headings

Lozenges:
For structures and relationships

Hexagons:
For structures and relationships

King-size hexagons:
Emphasize main points within a structure

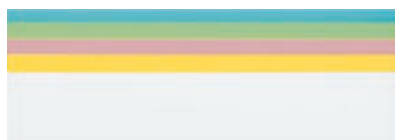

■ **Clouds:** set of 20, white with a red border

	Size	Ref.no.
Mini clouds	14.5 x 23 cm	7-250100
Small clouds	26.5 x 43 cm	7-250300
Large clouds	33.0 x 61 cm	7-250500

■ **Rectangles:** set of 500 or 250, colours available: white, yellow, pink, green, light blue, just add the right colour code to Ref.no. (see below)

■ **Rectangles:** set of 500, in five assorted colours: white, yellow, pink, green, light blue

	set of	Size	Colours	Ref.no.
Rectangles	500	9.5 x 20 cm	add colour code	7-2521xx
Rectangles	500	9.5 x 20 cm	five assorted colours	7-252199
Rectangles	250	9.5 x 20 cm	add colour code	7-2522xx

■ **Circles:** set of 500 or 250, five colours available

■ **Circles:** set of 500, in five assorted colours

	set of	Size	Colours	Ref.no.
Circles	500	diam. 9.5 cm	add colour code	7-2531xx
Circles	500	diam. 14 cm	add colour code	7-2533xx
Circles	500	diam. 19 cm	add colour code	7-2535xx

Circles	500	diam. 9.5 cm	five assorted colours	7-253199
Circles	500	diam. 14 cm	five assorted colours	7-253399
Circles	500	diam. 19 cm	five assorted colours	7-253599

Circles	250	diam. 9.5 cm	add colour code	7-2532xx
Circles	250	diam. 14 cm	add colour code	7-2534xx
Circles	250	diam. 19 cm	add colour code	7-2536xx

■ **Ovals:** set of 500 or 250, five colours available

■ **Ovals:** set of 500, in five assorted colours

	set of	Size	Colours	Ref.no.
Ovals	500	11 x 19 cm	add colour code	7-2541xx
Ovals	500	11 x 19 cm	five assorted colours	7-254199
Ovals	250	11 x 19 cm	add colour code	7-2542xx

■ **Strips for headlines, titles:** set of 100, five colours available

■ **Strips for headlines, titles:** set of 100, in five assorted colours

	set of	Size	Colours	Ref.no.
Strips	100	10 x 46 cm	add colour code	7-2550xx
Strips	100	10 x 46 cm	five assorted colours	7-255099

■ **Lozenges / hexagons:** set of 500 or 250, in five assorted colours

	set of	Size	Colours	Ref.no.
Lozenges	500	9.5 x 20.5 cm	five assorted colours	7-256199
Lozenges	250	9.5 x 20.5 cm	five assorted colours	7-256299
Hexagons	500	16.5 x 19.0 cm	five assorted colours	7-256399
Hexagons	250	16.5 x 19.0 cm	five assorted colours	7-256499

■ **King-size hexagons:** set of 100, in five assorted colours

	set of	Size	Colours	Ref.no.
Hexagons	100	16.5 x 29.5 cm	five assorted colours	7-256699



MODERATION

Moderation cards Emoticons

- Round moderation cards. The perfect support tool to visualise your ideas and comments.
- Useful for evaluation of single statements, ideas and results
- Simple and optical support, also if you are not able to draw!
- High attention value
- Diameter: 9.5 cm



Moderation cards	Cards	Set	Ref.no.
Emoticons Smile & Sad	100	1	7-257001
Emoticons Symbols	250	2	7-257002
Emoticons Smile	100	3	7-257003
Emoticons Neutral	100	4	7-257004
Emoticons Sad	100	5	7-257005

Moderation cards	Colour	Set 1	Set 2	Set 3	Set 4	Set 5
Question mark	blue	-	15	-	-	-
Thumb up	blue	-	15	-	-	-
Clock	blue	-	15	-	-	-
Hand eye	blue	-	5	-	-	-
Internet @	blue	-	5	-	-	-
Rain cloud	blue	-	5	-	-	-
Emotion smile	yellow	50	20	100	-	-
Emotion neutral	yellow	-	20	-	100	-
Emotion sad	yellow	50	20	-	-	100
Light bulb	yellow	-	5	-	-	-
Flower	yellow	-	10	-	-	-
Sun	yellow	-	5	-	-	-
Plus / Cross	green	-	10	-	-	-
Check mark	green	-	15	-	-	-
Joker	green	-	5	-	-	-
Cube / Dice	green	-	5	-	-	-
Exclamation mark	red	-	15	-	-	-
Stop sign	red	-	15	-	-	-
Flash	red	-	15	-	-	-
Minus	red	-	10	-	-	-
Heart	red	-	5	-	-	-
Forefinger	red	-	10	-	-	-
Fist	red	-	5	-	-	-

Stickers

- Pack of 1040
- 520 red, 520 blue
- 19 mm diameter

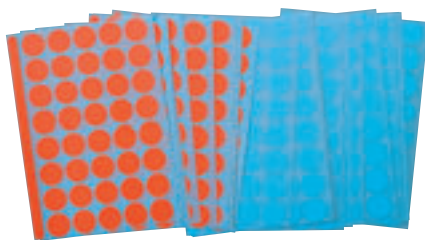

Ref.no. 7-243000

Moderation pins

- Extra thick 6 mm head for maximum grip
- Assorted pack of red, blue, green and yellow pins
- Pack of 200
- Diam. 6 mm x L 15 mm

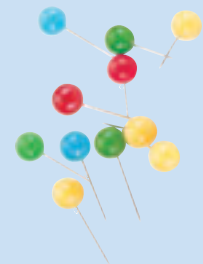

Ref.no. 7-241099

Clip-on pin cushion

- Blue pin cushion
- White plastic clip



Ref.no. 7-242000

The practical way to store pins as you dismantle your presentation.



Small telescopic pointer

- Pointer with integrated ballpoint
- Chrome-plated
- 13 cm long
- Extends to 62.5 cm
- Cash & carry packaging

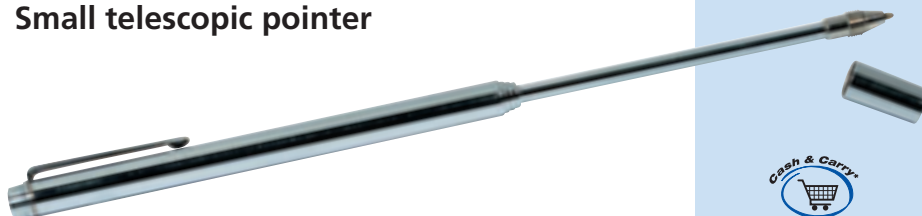

Ref.no. 7-570000

TZ 41 Presentation marker



- Specially for use on flipchart paper pads
- Special bleed-proof odourless ink
- Ink will not bleed through paper
- Chisel tip for bold downstrokes and stylish lettering
- Also suitable for moderation purposes
- For refilling this marker use the 100 ml refill ink bottle
Ref.no. 7-1558xx, capillary system
- Special water-based ink

Tip:



Stroke width:
approx. 2.0 – 5.0 mm

TZ 41 Box of 10, available in single colour
Please state colour code with order
Ref.no. 7-1550xx

TZ 41 Wallet of 4, assorted: black, red, blue and green
Ref.no. 7-155094

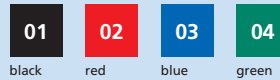

JUMBO TZ 48 Presentation marker



- Specially for use on flipchart paper pads
- Special bleed-proof odourless ink
- Chisel tip for thicker downstrokes
- Also suitable for moderation purposes
- For refilling this marker use the 100 ml refill ink bottle
Ref.no. 7-1559xx, dropper system
- Special water-based ink

Tip:



Stroke width:
approx. 4.0 – 12.0 mm

TZ 48 Box of 10, available in single colour
Please state colour code with order
Ref.no. 7-1555xx

TZ 48 Wallet of 4, assorted: black, red, blue and green
Ref.no. 7-155594

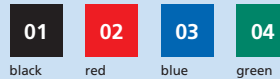

Refill ink for presentation markers



For presentation marker TZ 41,
capillary system
Ref.no. 7-1558xx



For presentation marker TZ 48,
dropper for precision filling
Ref.no. 7-1559xx

- Refilling your marker is environmentally friendly
- Special bleed-proof odourless ink
- 100 ml bottle
- Cap Off ink protects against rapid drying out
- Just add the right colour code to Ref.no.

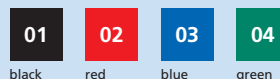

PRESENTATION AND DISPLAY

Legamaster wall rail systems are designed to suit any situation, purpose and location. They are extremely flexible in design offering a wide range of products to help you create your ideal combination.

Whiteboards, pinboards, flipcharts and projection screens are just examples of the products which are suitable for the rail systems. The elements glide smoothly behind and in front of each other enabling you to exchange the presentation elements.



Choose your ideal railsystem:

Legaline DYNAMIC and Legaline PROFESSIONAL rail systems are best suited to team work or as a multi-talented organiser for your own office.

Legamaster will help you find the best rail system to suit your particular needs.



Legaline DYNAMIC

- Unique design
- Height adjustable
- Innovative
- Ergonomic
- TÜV certified
- 2 channels

1 Components

Whiteboards
Pinboards

Tiltable flipchart (ergonomic)
Book shelf unit; 3 shelves (max. 30 kg total)
TV-Video shelf unit (max. 30 kg total)
Literature rack
Projection screen, to be fixed at any angle between 0 and 30°
e-Board Interactive

2 Features

Design 2-channel wall rail system
Components glide over and under each other
Height adjustable: all components can be set at a uniform height
Spacers with castors that can be placed at any angle

3 Various

Standard colour white RAL 9016 and anodised aluminium
Ergonomic design
Certificate from German testing body: TÜV/GS-certified



Legaline PROFESSIONAL

- Practical
- Functional
- 2 channels
- Versatile
- Prestigious

Whiteboards
Pinboards
Lino-cork bulletin pinboard
Flipchart
Book shelf unit; 3 shelves (max. 30 kg total)
TV-Video shelf unit (max. 30 kg total)
Literature rack
Projection screen, to be fixed at any angle between 0 and 30°

2-channel wall rail system
Components glide over and under each other

Standard colour white RAL 9016

PRESENTATION AND DISPLAY



Legaline DYNAMIC rail system



- Diverse selection of wall rail components
- 2-channel wall rail system
- Ergonomic rail system
- Components glide over and under each other
- All components can be set at a uniform height
- Certificate from German testing body, TÜV/GS-certified
- Space-saving
- Brilliant for use around corners
- Interchangeable; components can be moved and replaced with ease

- Unique design
- Innovative system
- Spacers with castors; no damage to your wall
- Easy to assemble
- Full-length paper holder; integrated in the rail
- End caps including stoppers
- White (RAL 9016) powder-coated or anodised aluminium
- Write on / dry wipe surface is guaranteed for 25 years when used in combination with Legamaster accessories





1 Pre-drilled holes for easy assembly



2 Simply push the upper rail section together, and that's it!



3 End cap and rail stopper in one



4 Integrated full length paper holder



Wall rail set

Legaline DYNAMIC

- Can be shortened or extended to suit individual requirements
- Dual channel accepts boards and other system components
- Comes standard with a full length paper holder; integrated in the rail
- Other lengths available on request (up to 240 cm maximum)
- Aluminium wall rails
- White (RAL 9016) powder-coated or anodised aluminium
- Recommended assembly height: 205 cm
- 2-channel wall rail comes complete with:
 - 1 extension adapter, 2 end caps and full length paper holder

Wall rail set with double channel, 240 cm length

Colour	Ref.no.
White (RAL 9016) powder-coated	7-330000
Anodised aluminium	7-330200

Wall rail set with double channel extension, 120 cm length

Colour	Ref.no.
White (RAL 9016) powder-coated	7-330100
Anodised aluminium	7-330400

Corner piece

Legaline DYNAMIC

- To attach two rails at a 90° angle

Colour	Ref.no.
White (RAL 9016)	7-333000
Light grey (RAL 7035)	7-333100

Set of upper suspension brackets

Legaline DYNAMIC

- Suspension bracket for the upper rail channel
- Spacer for the upper rail channel
- Upper suspension brackets are not suitable for TV - video shelf unit or book shelf unit

Colour	Ref.no.
For Legaline DYNAMIC white (RAL 9016)	7-332400
For Legaline DYNAMIC anodised aluminium	7-332500

PRESENTATION AND DISPLAY



Whiteboards

Legaline DYNAMIC

- High quality, scratch resistant, enamel surface
- Light-weight honeycomb board structure
- Magnetic; suitable for writing on with dry wipe board markers
- Ink wipes off easily, even after a prolonged period of time
- White (RAL 9016) powder-coated or anodised aluminium frame
- Baked enamel finish (fired at 800°C)
- Acid resistant and withstands cleaning even with the toughest detergents
- Comes complete with set of suspension brackets for the lower rail channel, full length marker tray, wall spacers and board marker
- Write on / dry wipe surface is guaranteed for 25 years when used in combination with Legamaster accessories

Colour	Height x Width	Ref.no.
White (RAL 9016)	100 x 100 cm	7-320062
Anodised aluminium	100 x 100 cm	7-320162
White (RAL 9016)	100 x 150 cm	7-320063
Anodised aluminium	100 x 150 cm	7-320163
White (RAL 9016)	100 x 200 cm	7-320064
Anodised aluminium	100 x 200 cm	7-320164
White (RAL 9016)	100 x 120 cm	7-320071
Anodised aluminium	100 x 120 cm	7-320171



Recommended accessories:

Whiteboard accessory set:
PROFESSIONAL kit Ref.no. 7-125500



Felt pinboards

Legaline DYNAMIC

- Durable felt surface
- Available in grey or blue felt
- White (RAL 9016) powder-coated or anodised aluminium frame
- Comes complete with set of suspension brackets for the lower rail channel and wall spacers

Colour	Height x Width	Felt	Ref.no.
White (RAL 9016)	100 x 150 cm	Blue	7-321563
White (RAL 9016)	100 x 150 cm	Grey	7-321663
Anodised aluminium	100 x 150 cm	Blue	7-321763
Anodised aluminium	100 x 150 cm	Grey	7-321863
White (RAL 9016)	100 x 120 cm	Blue	7-321571
White (RAL 9016)	100 x 120 cm	Grey	7-321671
Anodised aluminium	100 x 120 cm	Blue	7-321771
Anodised aluminium	100 x 120 cm	Grey	7-321871

Recommended accessories:

Push-pins in assorted colours
Ref.no. 7-1451xx

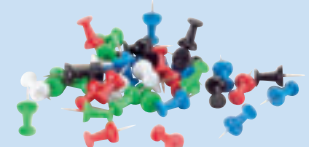





Wall rail flipchart

Legaline DYNAMIC

- Flipchart and whiteboard in one
- High quality, scratch resistant, enamel surface
- Magnetic; suitable for writing on with dry wipe board markers
- Detachable magnetic pad holder
- White (RAL 9016) powder-coated or anodised aluminium frame
- Torn-off sheets of paper can be displayed from the integrated paper holder
- Full length marker tray
- Pad holder adjustable to suit all major standard pad formats
- Ergonomic design, tiltable writing surface
- Shear mechanism enables smooth running
- Can be used around corners whilst retaining same tilt angle
- If writing surface is on an incline, board height stays the same
- H 108 cm x W 75 cm
- Weight: approx. 13.5 kg
- Comes complete with flipchart pad and suspension brackets for the upper rail channel
- Write on / dry wipe surface is guaranteed for 25 years when used in combination with Legamaster accessories

Colour

Ref.no.

	White (RAL 9016) powder-coated	7-324100
	Anodised aluminium	7-324200

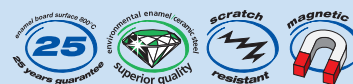

- Easy to move over boards on the lower channel
- Pad holder can be adjusted to suit all major standard paper pad formats



- Smooth running shear mechanism enables ergonomic writing surface
- Falls back against the wall when folded

PRESENTATION AND DISPLAY

Book shelf unit Legaline DYNAMIC



- Unit with three adjustable shelves
- Elegant design; rounded shelves
- White (RAL 9016) powder-coated or anodised aluminium frame
- White / light grey shelves
- Maximum load for the total product: 30 kg
- Book shelf unit with three shelves, H 109 x W 90 x D 34 cm
- Comes complete with suspension brackets for lower rail channel and wall spacers

Colour	Ref.no.
White (RAL 9016) powder-coated	7-325100
Anodised aluminium	7-325200

TV-Video shelf unit Legaline DYNAMIC



- Unit with two adjustable shelves
- Elegant design; rounded shelves
- White (RAL 9016) powder-coated or anodised aluminium frame
- White / light grey shelves
- Maximum load for the total product: 30 kg
- TV/video shelf unit with two shelves, H 109 x W 90 x D 44 cm
- Comes complete with suspension brackets for lower rail channel and wall spacers

Colour	Ref.no.
White (RAL 9016) powder-coated	7-325300
Anodised aluminium	7-325400

Literature rack Legaline DYNAMIC



- Ideal for displaying magazines or catalogues
- Unit with eight pockets
- Crystal-clear acrylic
- Suitable for standard A4 formats
- White (RAL 9016) powder-coated or anodised aluminium frame
- Pocket dimensions: W 22.5 x D 3.3 x H 25 cm
- Literature rack with 8 pockets, H 109 x W 55 cm
- Comes complete with suspension brackets for upper rail channel and wall spacers

Colour	Ref.no.
White (RAL 9016) powder-coated	7-325500
Anodised aluminium	7-325600

Display magazines and catalogues in a nice and neat way!



Projection screen 4:3 Legaline DYNAMIC



- Specially designed for data / video projection on the rail system
- Spring mechanism allowing screen to be fixed at any angle between 0 and 30°
- Maximum viewing angle 50°
- White (RAL 9016) powder-coated or anodised aluminium frame
- Fixed, framed projection screen
- Pre-assembled
- Comes complete with suspension brackets for upper rail channel and wall spacers

Colour	Screen dimension Height x Width	Viewing size Height x Width	Ref.no.
White (RAL 9016)	114 x 156 cm	109 x 146 cm	7-326551
Anodised aluminium	114 x 156 cm	109 x 146 cm	7-326651
White (RAL 9016)	151 x 206 cm	146 x 196 cm	7-326554
Anodised aluminium	151 x 206 cm	146 x 196 cm	7-326654

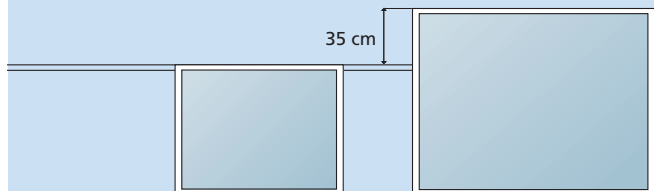

- Space required above rail:
Ref.no. 7-326551 and Ref.no. 7-326651: 0 cm
Ref.no. 7-326554 and Ref.no. 7-326654: approx. 35 cm
- Minimum height of room approx. 2.7 m:
Ref.no. 7-326554 and Ref.no. 7-326654

DYNAMIC e-Board Interactive



- Turn your projection surface into an interactive touch screen. Use an A/V projector for projecting on the special e-Board Interactive projection surface
- Integral eBeam technology
- In various formats
- For use on the upper rail channel
- DYNAMIC e-Board comes complete with:
Software (multi-language / CD-ROM), eBeam Edge Stylus, Fixing kit for wall attachment, 4.5 m cable for USB connection

DYNAMIC e-Board Interactive incl. brackets for Legaline DYNAMIC Anodised aluminium

Height x Width	Projection area	Ref.no.
91 x 133 cm	diagonal 146 cm / 58"	7-160648
121 x 173 cm	diagonal 196 cm / 77"	7-160652



Ask us for more
interactive solutions!

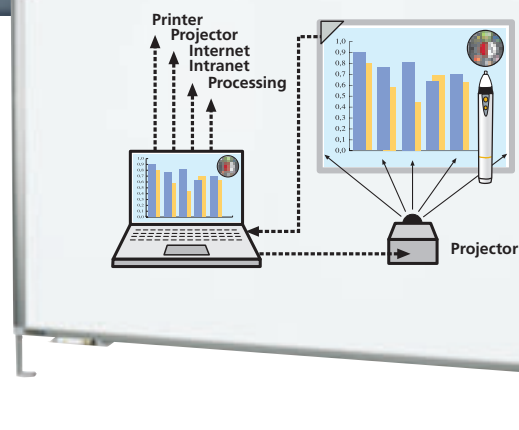

PRESENTATION AND DISPLAY

Legaline PROFESSIONAL rail system



- Large selection of components
- 2-channel rail system
- Components glide over and under each other
- Space-saving
- Flexible, versatile; extendable
- Multi-purpose; suitable for all kinds of rooms
- Practical; even goes around corners
- Interchangeable; components can be moved and replaced with ease
- Full-length paper holder
- End caps including stoppers
- White (RAL 9016) powder-coated
- Write on / dry wipe surface is guaranteed for 25 years when used in combination with Legamaster accessories



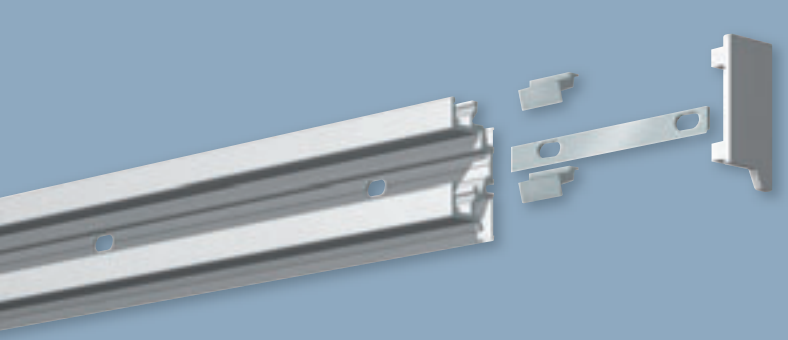

Wall rail set

Legaline PROFESSIONAL

- Can be shortened or extended to suit individual requirements
- Dual channel accepts boards and all other system components
- Comes standard with an extra integrated track that accepts tubular paper holders
- Aluminium wall rails white (RAL 9016 powder-coated)
- Recommended assembly height: 205 cm

Wall rail with double channel 240 cm

- Comes complete with:
 - 1 Extension adapters
 - 4 Rail stoppers
 - 2 End caps
 - 1 Decor strips, white
 - 36 Tubular paper holders
 - 1 Fastenings and fittings

Ref.no. 7-310000

Wall rail set with double channel extension 120 cm

- Comes complete with:
 - 1 Decor strips, white
 - 18 Tubular paper holders
 - 1 Fastenings and fittings

Ref.no. 7-310500



1 Mount the rail set on the wall



2 Insert the paper holders in the integrated rail track



3 Make written flipchart papers or posters visible by hanging them onto the rail



Corner piece

Legaline PROFESSIONAL

- To attach two rails at a 90° angle
- Best when used in combination with Legamaster wall rail set with double channel extension 120 cm

Ref.no. 7-313000



Set of upper suspension brackets

Legaline PROFESSIONAL

- Glides easily back and forth
- For positioning components on the upper rail channel
- Special runners so that boards glide easily
- Set comprising 2 brackets and 2 spacers which open outwards so that boards can be aligned vertically
- For upper rail channel
- Max. load 50 kg / set

Ref.no. 7-312400

PRESENTATION AND DISPLAY

Whiteboards

Legaline PROFESSIONAL



- High quality, scratch resistant enamel surface
- Light-weight honeycomb board structure
- Magnetic; suitable for writing on with dry wipe board markers
- White (RAL 9016) powder-coated aluminium frame
- Baked enamel finish (fired at 800°C)
- Acid resistant and withstands cleaning even with the toughest detergents
- Comes complete with set of suspension brackets for the lower rail channel, full length marker tray, wall spacers and board marker
- Write on / dry wipe surface is guaranteed for 25 years when used in combination with Legamaster accessories

Height x Width	Ref.no.
60 x 90 cm	7-300043
90 x 120 cm	7-300054
90 x 180 cm	7-300056
100 x 150 cm	7-300063
120 x 90 cm	7-300071
120 x 180 cm	7-300074



Recommended accessories:
 Whiteboard accessory set:
 PROFESSIONAL kit Ref.no. 7-125500
 Flipchart pad holder Ref.no. 7-123000



Lino-cork bulletin pinboard

Legaline PROFESSIONAL



- Light grey, high quality cork linoleum surface material
- Highly versatile
- White (RAL 9016) powder-coated aluminium frame
- Comes complete with set of suspension brackets for the lower rail channel and wall spacers

Height x Width	Ref.no.
90 x 120 cm	7-301154

Recommended accessories:
 Push-pins in assorted colours
 Ref.no. 7-1451xx

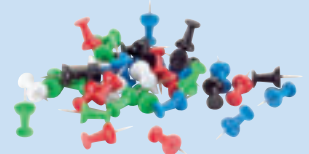

*Make use of the space
 the rail system offers
 by hanging versatile
 products on it.*

Felt pinboards

Legaline PROFESSIONAL



- Durable felt surface
- Versatile
- White (RAL 9016) powder-coated aluminium frame
- Comes complete with set of suspension brackets for the lower rail channel and wall spacers

Height x Width	Felt	Ref.no.
90 x 120 cm	Blue	7-301554
90 x 120 cm	Grey	7-301654

Recommended accessories:
Push-pins in assorted colours
Ref.no. 7-1451xx

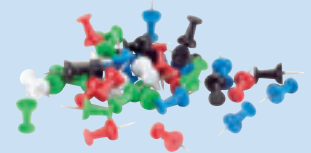

Wall rail flipchart

Legaline PROFESSIONAL



- Flipchart and whiteboard in one
- Detachable magnetic pad holder
- White (RAL 9016) powder-coated aluminium frame
- 4 flipchart pads can be stored behind the whiteboard
- Torn-off sheets of paper can be displayed from the rail's extra track
- Full length marker tray
- Adjustable pad holder to suit all major standard paper pad formats
- Flipchart opens outwards, making it easy to flip over used pages
- Magnetic; suitable for writing on with dry wipe board markers; enamel finish
- H 108 cm x W 75 cm
- Weight: approx. 13.5 kg
- Comes complete with flipchart pad and suspension brackets for the upper rail channel
- Write on / dry wipe surface is guaranteed for 25 years when used in combination with Legamaster accessories

Ref.no. 7-304300



PRESENTATION AND DISPLAY

Book shelf unit

Legaline PROFESSIONAL



- Adjustable shelf positions
- White (RAL 9016) powder-coated aluminium frame
- Extremely multi-purpose
- Maximum load for the total product: 30 kg
- Comes complete with suspension brackets for upper rail channel
- External dimensions:
H 108 cm (113.5 cm incl. suspension brackets) x W 85 cm
- Approx. weight: 20.5 kg
- Book shelf unit with three 30 x 80 cm shelves

Ref.no. 7-305100



TV-Video shelf unit

Legaline PROFESSIONAL



- Adjustable shelf positions
- White (RAL 9016) powder-coated aluminium frame
- Maximum load for the total product: 30 kg
- Comes complete with suspension brackets for upper rail channel
- External dimensions:
H 108 cm (113.5 cm incl. suspension brackets) x W 85 cm
- Approx. weight: 20.5 kg
- TV/video shelf unit with two 50 x 80 cm shelves

Ref.no. 7-305300



Literature rack Legaline PROFESSIONAL



- Ideal for displaying magazines or catalogues
- Literature rack with 8 pockets
- Crystal clear acrylic
- Suitable for standard A4 formats
- White (RAL 9016) powder-coated aluminium frame
- Comes complete with suspension brackets for upper rail channel
- 115 cm (121 cm incl. suspension brackets) x H 50 x D 14 cm
- Weight: 8 kg
- Pocket dimensions: W 22 x D 3.3 x H 25 cm

Ref.no. 7-305500

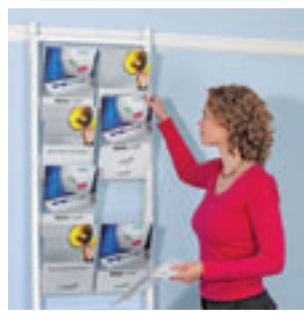

Projection screen Legaline PROFESSIONAL

- Specially for use on the rail system
- Special mechanism allowing screen to be fixed at any angle between 0 and 30°
- Maximum viewing angle 50°
- White (RAL 9016) powder-coated aluminium frame
- Comes complete with suspension brackets for upper rail channel and wall spacers

Height x Width	Weight	Ref.no.
150 x 150 cm	14 kg	7-306451
180 x 180 cm	16 kg	7-306453

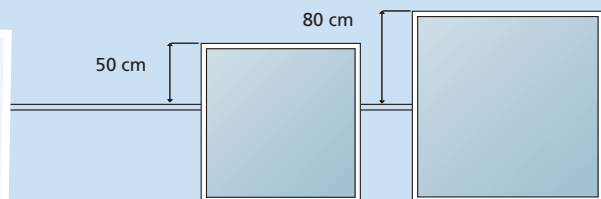

- Space required above rail:
Ref.no. 7-306451: 50 cm
Ref.no. 7-306453: 80 cm
- Minimum height of room approx. 3 m: Ref.no. 7-306453

PRESENTATION AND DISPLAY

PROFESSIONAL presentation cabinet



- Main board and two doors contain enamel steel, magnetic whiteboard
- Both doors include a flipchart paper pad holder for every paper pad size
- Lockable doors
- Pull out matt-white projection screen
- Keystone eliminator bracket
- Available in white or beech finish
- Ample marker tray with double groove
- White cabinet backing
- Felt protection between the doors and the cabinet frame
- Optional: mobile stand in matt anthracite or white with 4 lockable castors
- Overall dimensions (closed): H 120 x W 151 x D 11 cm
Overall dimensions (open): H 120 x W 300 x D 11 cm
- Cabinet dimensions with stand: H 195 x W 160 x D 75 cm
- Projection area: approx. H 135 x W 125 cm
- Doors open out 180°
- Includes: eraser (TZ 4), 1 set board markers TZ 1, magnets, flipchart pad and fixing kit

Colour	Ref.no.
White	7-703001
Beech	7-703003



PREMIUM^{PLUS} presentation cabinet



- Main board contains enamel steel, magnetic whiteboard
- One door includes a pad holder for every flipchart paper pad size
- Pull out matt-white projection screen
- Keystone eliminator bracket
- Available in white or beech finish
- Ample marker tray with double groove
- White cabinet backing
- Optional: mobile stand in matt anthracite or white with 4 lockable castors
- Overall dimensions (closed): H 120 x W 151 x D 11 cm
Overall dimensions (open): H 120 x W 300 x D 11 cm
- Cabinet dimensions with stand: H 195 x W 152 x D 75 cm
- Projection area: approx. H 135 x W 125 cm
- Doors open out 180°

Colour	Ref.no.
White	7-704001
Beech	7-704003



Mobile presentation cabinet stand



- Solid mobile steel stand for the Legamaster presentation cabinets
- Matt anthracite or white lacquered finish
- 4 lockable castors for added stability
- Conduct presentations wherever you choose

Colour	Ref.no.
White	7-702801
Matt anthracite	7-702802

Accessories



Retractable marker TZ 14	Ref.no. 7-1125xx	page 133
Board marker TZ 1	Ref.no. 7-1100xx	page 133
Board marker TZ 100	Ref.no. 7-1105xx	page 134
Board marker PLUS TZ 10	Ref.no. 7-1110xx	page 134
Board marker TZ 140	Ref.no. 7-1140xx	page 135
Board marker TZ 150	Ref.no. 7-1150xx	page 135
Board marker JUMBO TZ 180	Ref.no. 7-1180xx	page 135
Refill ink for board markers	Ref.no. 7-1195xx	page 136
Refill ink for board markers	Ref.no. 7-1199xx	page 136
Refill ink for TZ 14	Ref.no. 7-1129xx	page 136

Small whiteboard eraser	Ref.no. 7-120100	page 137
Magnetic whiteboard eraser	Ref.no. 7-120300	page 137
Whiteboard eraser TZ 4	Ref.no. 7-120500	page 137
Whiteboard cleaner TZ 6	Ref.no. 7-121000	page 138
Whiteboard cleaner TZ 7	Ref.no. 7-121200	page 138
Whiteboard cleaner TZ 8	Ref.no. 7-121300	page 138
Whiteboard cleaner TZ 66	Ref.no. 7-121400	page 138
MagicWipe	Ref.no. 7-121500	page 139

Marker holder	Ref.no. 7-122000	page 139
Board assistant	Ref.no. 7-122500	page 139
Tacking magnets	Ref.no. 7-1810xx - Ref.no. 7-1814xx	page 146

Whiteboard accessory set: PROFESSIONAL kit	Ref.no. 7-125500	page 140
Whiteboard accessory set: STARTER kit	Ref.no. 7-125000	page 141
Whiteboard accessory set: BASIC kit	Ref.no. 7-125100	page 141

Presentation marker TZ 41	Ref.no. 7-1550xx	page 142
Presentation marker JUMBO TZ 48	Ref.no. 7-1555xx	page 142
Refill ink for presentation markers	Ref.no. 7-1558xx	page 142
Refill ink for presentation markers	Ref.no. 7-1559xx	page 142

Push-pins in assorted colours	Ref.no. 7-1451xx	page 145
Push-pins, assorted	Ref.no. 7-145299	page 145

PROJECTION

Each situation is unique and the choice for the right projection screen is influenced by factors such as ambient light, light output, projector set-up and the presentation room. Legamaster offers a wide range of projection screens. A solution for every situation.

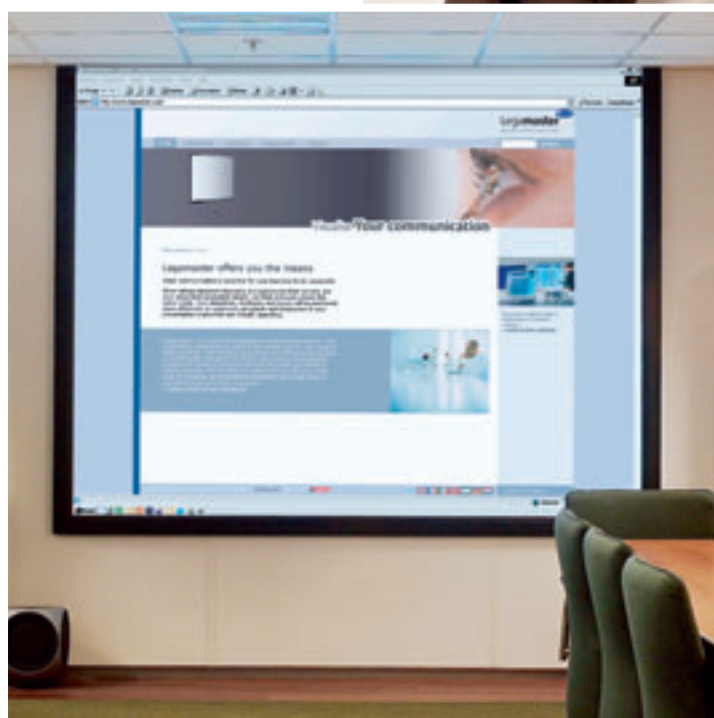

See the difference

Choosing the right projection screen is extremely important!

1 Black border

The black border increases the perceived clarity of the projected image

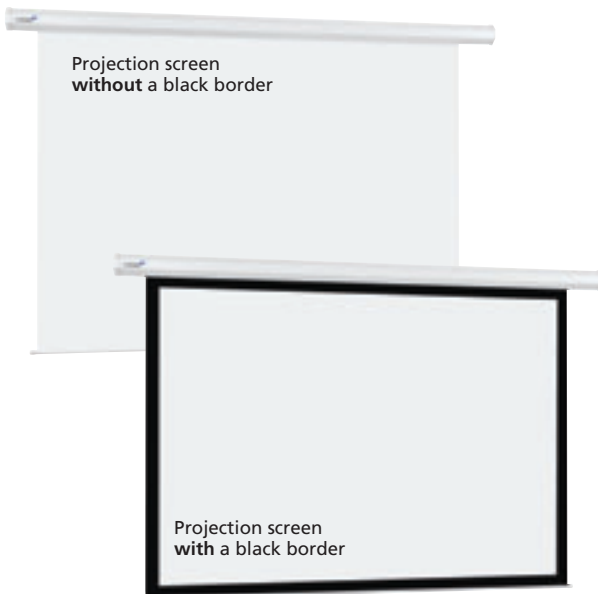

2 Projection screen

With a projection screen, the visual information will be shown without any quality loss. The projected light will be reflected towards the audience.



Projection on a wall

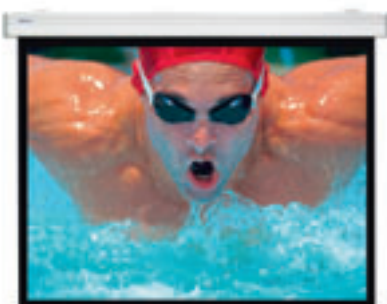

Projection on a projection screen

Screen qualities

There are many projection screens on the market with varying quality levels.

To make the selection process easier, Legamaster projection screen names give a clear indication on the quality level of the screen.



For intensive use

Top quality screens which meet the highest requirements, for the demanding user.

PROFESSIONAL projection screens



For regular use

Excellent projection screens with a good price / quality ratio.

PREMIUM projection screens



For occasional use

A good alternative for price oriented buyers.

ECONOMY projection screens



PROJECTION

The 4 steps

The next 4 steps provide you with the most important selection criteria which will help you to choose the right projection screen, while taking your specific circumstances and needs into account.

1 Screen type

There are three projection screen types:

- electrically operated projection screen
- manually operated projection screen
- mobile projection screen

A mobile (portable) projection screen is the best choice if a variety of locations are used for projection. However, if the projection room is permanent, then you may choose from an electrically- or manually operated screen. Depending on your personal preference and budget.

For special projection solutions, such as interactive projection, see page 80.

2 Aspect ratio

Depending on the projection method, the projected image will have a certain width / height ratio.

For the best results, we advise to select a projection screen with the same ratio as that of the projected image.

The following aspect ratios are distinguished:

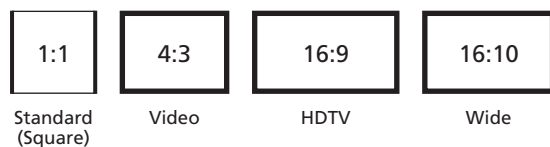

3 Screen dimensions

The dimensions and hanging position of the projection screen can be determined by following this guideline:

Dimensions of the projection screen

Height (X) of the projection screen = 1/6 of the distance from the projection screen to the last row of chairs.

width of the projection screen =



width = height

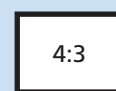

4:3 width = 1.33 x height

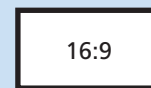

16:9 width = 1.78 x height

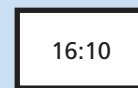

16:10 width = 1.60 x height

Optimum viewing height

The most optimum distance from the bottom of the projection screen to the floor is:

In case of:

Professional use = approximately 125 cm

Home Cinema use = minimum 60-90 cm

Minimum viewing distance

The optimum perception of the projected image is determined by:

Distance to the first (D) row of audience = diagonal (D) dimension of the screen

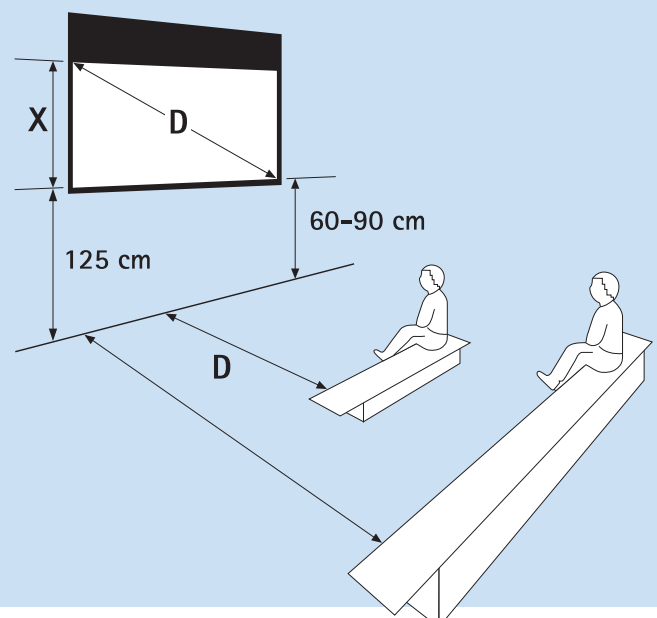

4

Choosing the right screen fabric

Please choose from the screen fabrics as described below. Please take into account primarily the light output of the projector, the ambient light, the position of the projector (on the ceiling or placed at seat height) and the layout of the presentation room.

Wide viewing angle 100°
Matte white

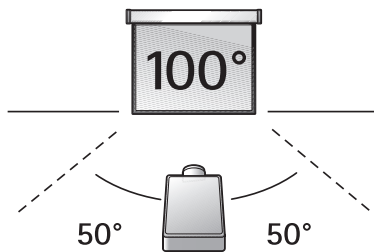

Legamaster projection screen fabrics:

A diffusion projection screen surface spreads the light evenly and has a wide viewing angle.

Within the diffusion screen fabrics we offer the following screen fabric types:

- matte white
- matte white high gain

Suitable choice for projection settings that require a wide viewing angle (max. 50° L/R) or in which a projector with a high light output is used. A diffusion screen fabric can also be used in situations in which the projector is placed at seat height or where the projector is mounted on the ceiling.

PROFESSIONAL and PREMIUM projection screens: screen fabrics are tested for fire resistance and meet the norm B2.

Screen fabric	Gain	Viewing angle L/R	Fire safety
Matte white High Gain	2.2	70°	B2
Matte white	1.0	120°	B2



At the screen pages you can find the screen fabric per screen.

Easy Install



Flexible installation with Easy Install

The variable hanging system ensures that the Legamaster projection screens are easy to install.*

Easy Install results in major time savings and this naturally also results in a reduction in the installation costs.

Easy Install is an absolute improvement in the ease of installation for the professional market. Thanks to the plug & play installation, consumers can easily install an electrical projection screen in their own homes.

1

Simplicity and ease



The principle behind Easy Install is simple.

First two brackets are mounted to the wall or ceiling, and then the screen can be easily slid into the brackets and secured with screws.

Even the largest screens can be quickly and easily installed using this system.

2

Flexible choice for drill holes



Thanks to Easy Install, the screen width no longer determines the position of the points of suspension. The mounting brackets may be mounted to the wall or ceiling within 50 cm of the two ends of the screen. It is also possible to make corrections either to the left or right after hanging.

This means the end of fixed drilling measurements. A Legamaster projection screen is easy to install and always hangs perfectly in no time.

3

Plug & play accessories



With the plug & play accessories, everyone can easily install an electrical projection screen:

connect the plug to the screen, conceal the wiring neatly in the end caps, and the projection screen is ready to use.

*Legamaster Easy Install projections screens:

- PROFESSIONAL electrical RF projection screen, page 82
- PREMIUM electrical (RF) projection screen, page 83
- PROFESSIONAL manual CSR projection screen, page 85
- PROFESSIONAL manual projection screen, page 86

PROJECTION



PROFESSIONAL projection board FLEX

For the PROFESSIONAL projection board FLEX the technology of the Legamaster e-Boards has been used to design a high quality, scratch resistant projection surface with good image and contrast quality. The projection board FLEX is perfect for projection with an a/v projector. Without leaving a "hotspot" on the board.

At the same time, the boards can be used as a wet-wipeable whiteboard and are also suitable for use in combination with eBeam Edge or eBeam Engage.

The PROFESSIONAL projection board FLEX offers much flexibility in creating a solution that fits your demand for projection: Everyone can assemble his or her own ideal board by choosing:

- 4:3 or 16:10 widescreen format
- Board size
- With or without side panels (standard option for 77" or 88" boards)
- Several options for the surface of the side panels
- Long or short marker tray
- Height adjustable or not
- Wall mount, mobile stand or on columns



Optional: PROFESSIONAL Hybrid board FLEX

The Hybrid version of the FLEX assortment is an optimal multi-functional solution in environments where whiteboards and projectors both are frequently used.

For more information about this board, please contact your Legamaster dealer.

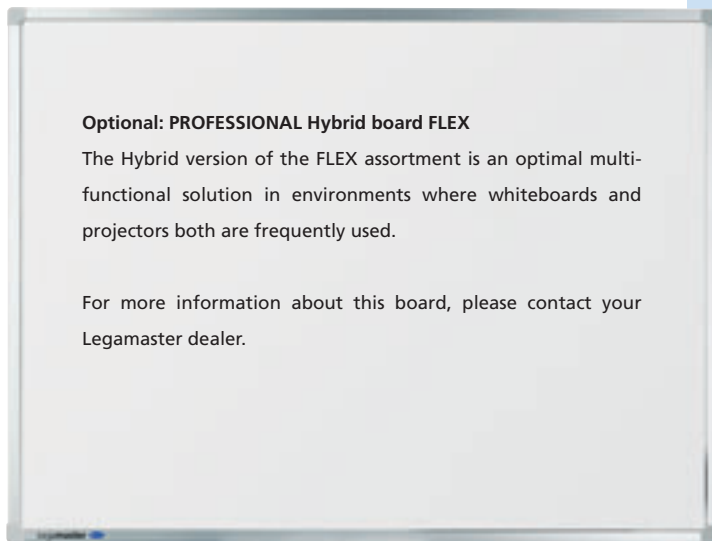

- Suitable for use in combination with eBeam Edge and the electronic pen (stylus)



- High quality, scratch resistant enamel projection surface
- Perfect for projection with a/v projector
- Good image and contrast quality:
No "hotspot" visible when projecting with average a/v projector
- Aluminum frame with light grey plastic corner caps
- Baked enamel finish (fired at 800°C), which results in a very durable surface
- Easy wall mounting with concealed slot system
- Particularly well suited for long term use
- Long or short marker tray
- Projection surface is guaranteed for 25 years when used in conjunction with the interactive stylus

Please note that the PROFESSIONAL projection board FLEX can be used as a whiteboard but is wet-wipeable and not dry-wipeable.

	Product name	Projection format	External dimensions	Internal dimensions (projection surface)	Ref.no.
4:3	PROFESSIONAL projection board FLEX 57"	57" / 144 cm	90 x 127 cm	86 x 123 cm	7-190011
	PROFESSIONAL projection board FLEX 77"	77" / 197 cm	120 x 168 cm	118 x 164 cm	7-190012
	PROFESSIONAL projection board FLEX 99"	99" / 252 cm	155 x 212 cm	151 x 208 cm	7-190013
16:10	PROFESSIONAL projection board FLEX 88" W	88" / 223 cm	122 x 200 cm	118 x 196 cm	7-190014



PROFESSIONAL electrical built-in RF projection screen

- Attractive and durable built-in solution. Building in a projection screen efficiently was never so easy
- Includes built-in radio frequency receiver, making it possible to operate the screen using the remote control supplied
- Closure formed by the projection screen surface slat bar ensures that ceiling mounting is inconspicuous
- Easy Serviceability System: once installed, the motor and screen surface remain accessible making adjustments and carrying out maintenance possible. The bottom panel and case remain connected to each other
- Easy to build into existing non-modular ceilings
- Easy installation with optional wall and ceiling brackets, prewired for electrical installation



- Concealed-in-ceiling projection screen
- Matte white screen fabric
- Screen fabric is flame retardant
- Black border increases perceived clarity of the projected image
- Quiet, fast motor with a 5-year guarantee
- Formats: video (4:3) and wide (16:10)

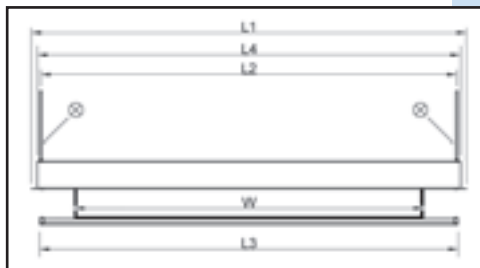
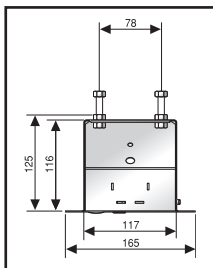

- Case colour is white; RAL 9016
- Sturdy construction
- Projection screen is pre-assembled
- Quality marks: CE, TÜV/GS



Screen dimension Height x Width	Viewing size Height x Width	Nominal Diagonal Inches	kg
------------------------------------	--------------------------------	----------------------------	----

4:3

Format for data / video projection

153 x 200 cm	143 x 190 cm	94"	20
183 x 240 cm	173 x 230 cm	113"	24
228 x 300 cm	218 x 290 cm	143"	29

16:10

Format for wide screen use

129 x 200 cm	119 x 190 cm	88"	21
154 x 240 cm	144 x 230 cm	107"	23
191 x 300 cm	181 x 290 cm	135"	28

Housing dimensions				Gain	Ref.no.
L1 mm	L2 mm	L3 mm	L4 mm		

2259	2197	2187	2209	1.0	7-550554
2659	2597	2587	2609	1.0	7-550556
3259	3179	3187	3209	1.0	7-550559

2259	2197	2187	2209	1.0	7-550513
2659	2597	2587	2609	1.0	7-550514
3259	3179	3187	3209	1.0	7-550570

PROJECTION

PROFESSIONAL electrical RF projection screen



- Top quality electrical projection screen in two aspect ratios
- Includes built-in radio frequency receiver, making it possible to operate the screen using the remote control supplied
- Easy to mount onto a wall or ceiling thanks to the Easy Install system
- The possibilities offered by Easy Install Plug and Play make connecting the screen fast and easy
- The automatic stop employed when extending and retracting the projection screen surface guarantees a long life span
- The triangular slat bar fully rolls up into the case for a clean finish
- Low noise, high speed motor

- Matte white screen fabric
- Screen fabric is flame retardant
- Black border increases perceived clarity of the projected image
- Quiet, fast motor with a 5-year guarantee
- Formats: video (4:3) and wide (16:10)

- Case colour is white; RAL 9016
- Sturdy construction
- Easy Install system
- (Cordless) RF remote control
- Quality marks: CE, TÜV/GS

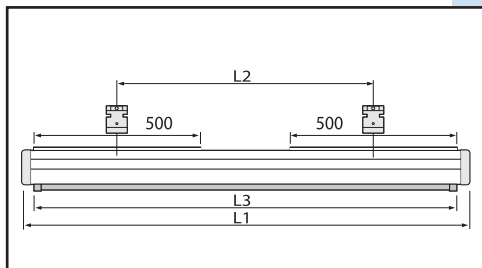
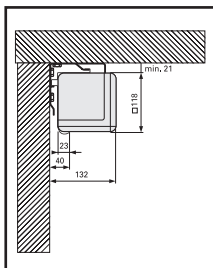

Screen dimension	Viewing size	Nominal	kg
Height x Width	Height x Width	Diagonal	Inches

Format for data / video projection

4:3

153 x 200 cm	143 x 190 cm	94"	21
183 x 240 cm	173 x 230 cm	113"	26
228 x 300 cm	218 x 290 cm	143"	33

Format for wide screen use

16:10

129 x 200 cm	119 x 190 cm	88"	20
154 x 240 cm	144 x 230 cm	107"	25
191 x 300 cm	181 x 290 cm	135"	28

Housing dimensions	Gain	Ref.no.
L1 mm	L2 mm	L3 mm

2135	1149-1949	2040	1.0	7-550454
2535	1549-2349	2440	1.0	7-550456
3135	2149-2949	3040	1.0	7-550459

2135	1149-1949	2040	1.0	7-550613
2535	1549-2349	2440	1.0	7-550614
3135	2149-2949	3040	1.0	7-550670

PREMIUM electrical (RF) projection screen



- Electrical projection screen of professional quality
- Only PREMIUM electrical RF projection screen: Including built-in radio frequency module, making it possible to operate the screen using the remote control supplied
- Easy to mount onto a wall or ceiling thanks to the Easy Install system
- The possibilities offered by Easy Install Plug and Play make connecting the screen fast and easy
- The automatic stop employed when extending and retracting the projection screen surface guarantees a long life span

- Matte white screen fabric
- Compact case with motor
- Screen fabric is flame retardant
- Black border increases perceived clarity of the projected image
- Formats: square (1:1) and video (4:3)

- Case colour is white; RAL 9016
- Easy Install system
- Remote control
- Compact design
- Quality marks: CE, TÜV/GS

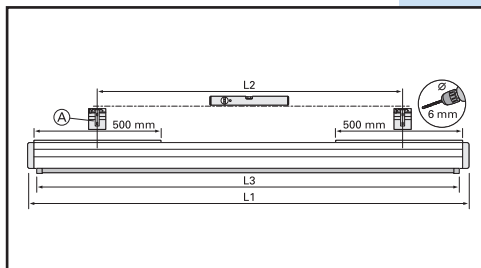
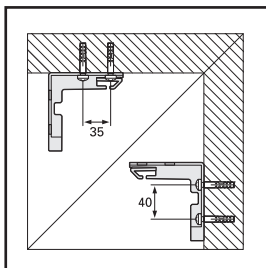

Screen dimension Height x Width	Viewing size Height x Width	Nominal Diagonal Inches	kg
------------------------------------	--------------------------------	-------------------------------	----

Standard format

1:1

180 x 180 cm	173 x 173 cm	-	12
200 x 200 cm	195 x 195 cm	-	14
240 x 240 cm	230 x 230 cm	-	18

Format for data / video projection

4:3

153 x 200 cm	143 x 190 cm	100"	14
183 x 240 cm	173 x 230 cm	120"	18
213 x 280 cm	203 x 270 cm	140"	22

Housing dimensions		
L1 mm	L2 mm	L3 mm

1914	1734	1820
2134	1954	2040
2534	2354	2440

2134	1954	2040
2534	2354	2440
2934	2754	2840

Gain

Ref.no.
electrical RF

Ref.no.
electrical

1.0	7-551753	7-553053
1.0	7-551755	7-553054
1.0	7-551756	7-553056

1.0	7-551854	7-553154
1.0	7-551856	7-553156
1.0	7-551858	7-553158

PROJECTION



ECONOMY electrical projection screen

- Entry-level electrical projection screen
- Particularly suitable for regular to light use
- Wall or ceiling attachment
- White steel screen housing with plastic end caps
- Easy to mount: fixing points on the end caps of the screen housing
- Low-noise, synchronous motor
- Includes remote control to operate the screen by touching one button
- Black border increases perceived clarity of the projected image
- CE approved
- Comes complete with fittings for wall/ceiling attachment, remote control, EU plug and mounting manual

- Matte white screen fabric
- Screen housing shape: octagon
Except for size 180 x 240 cm: hexagon
- Colour of back of screen fabric: white
- Automatic stop
- Voltage: 230 V
- Power: 40 W
- Frequency: 50 Hz
- Cable length: approx. 2 m



Recommended accessory:
Laser pointer LX 1 Ref.no. 7-575300

Format	Size	Black Border
1:1	Size up to 240 cm	3 cm left and right
1:1	Size bigger than 240 cm	5 cm left and right
4:3	Size up to 240 cm	3 cm left-right-bottom, 5 cm top
4:3	Size bigger than 240 cm	5 cm all four sides



Screen dimension
Height x Width

Viewing size
Height x Width

Standard format

1:1

160 x 160 cm	152 x 152 cm
180 x 180 cm	174 x 174 cm
200 x 200 cm	194 x 194 cm

Format for data / video projection

4:3

120 x 160 cm	111 x 148 cm
150 x 200 cm	143 x 190 cm
180 x 240 cm	173 x 230 cm

Viewing size
Inch (H x W x diagonal)

kg

Gain

Ref.no.

60" x 60"	9	1.0	7-556752
70" x 70"	13	1.0	7-556753
80" x 80"	16	1.0	7-556754

63" x 47" / 80"	9	1.0	7-556852
79" x 59" / 100"	13	1.0	7-556854
96" x 71" / 120"	18	1.0	7-556860

PROFESSIONAL manual CSR projection screen



- Professional manual projection screen with the reliable Controlled Screen Return, available in two aspect ratios
- The new Legamaster Controlled Screen Return ensures a strong spring mechanism that allows the projection screen surface to be extended and retracted smoothly
- The PROFESSIONAL manual CSR is available with the new CSR spring mechanism up to a width of 240 cm
- The screen locks into place at 13 cm intervals for required height adjustment
- Easy to mount on a wall or ceiling thanks to the Easy Install system

- Matte white screen fabric
- Screen fabric is flame retardant
- Black border increases perceived clarity of the projected image
- Formats: video (4:3) and wide (16:10)

- Case colour is white; RAL 9016
- Easy Install system
- Quality marks: CE

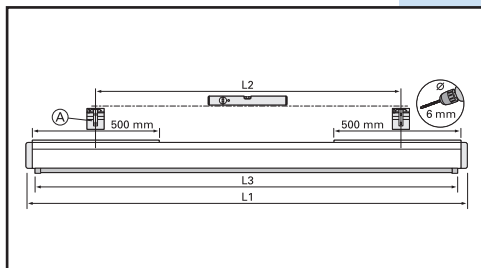
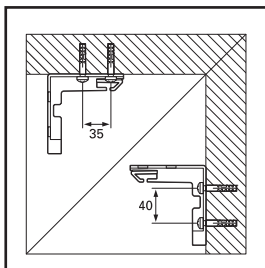

Aspect Ratio	Screen dimension		Viewing size		Nominal Diagonal	kg
	Height x Width	Height x Width	Height x Width	Inches		
4:3	Format for data / video projection					
	138 x 180 cm	126 x 168 cm	83"	11		
	153 x 200 cm	143 x 190 cm	94"	13		
	183 x 240 cm	173 x 230 cm	113"	16		
16:10	Format for wide screen use					
	115 x 180 cm	105 x 168 cm	85"	11		
	129 x 200 cm	119 x 190 cm	88"	12		
	154 x 240 cm	144 x 230 cm	107"	16		
		Housing dimensions			Gain	Ref.no.
		L1 mm	L2 mm max.	L3 mm		
		1914	1734	1820	1.0	7-543453
		2134	1954	2040	1.0	7-543454
		2534	2354	2440	1.0	7-543456
		1914	1734	1820	1.0	7-543412
		2134	1954	2040	1.0	7-543413
		2534	2354	2440	1.0	7-543414

PROJECTION

PROFESSIONAL manual projection screen



- Professional manual projection screen, available in two aspect ratios
- The spring mechanism allows the projection screen surface to be extended and retracted quickly and smoothly
- The screen locks into place at 20 cm intervals for flexible height adjustment
- Easy to mount on a wall or ceiling thanks to the Easy Install system

- Matte white screen fabric
- Screen fabric is flame retardant
- Black border increases perceived clarity of the projected image
- Formats: video (4:3) and wide (16:10)

- Case colour is white; RAL 9016
- Easy Install system
- User friendly pull-out system
- Supplied complete with a pull cord
- Sturdy construction
- Quality marks: CE

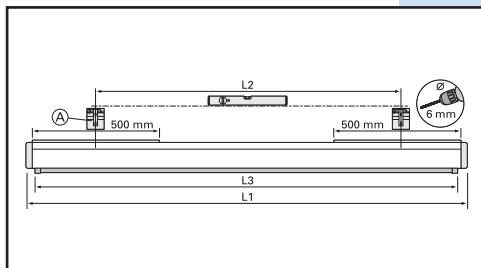
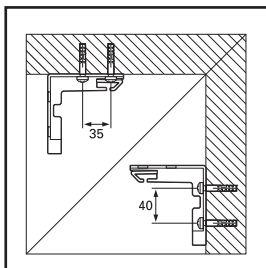

Screen dimension Viewing size Nominal kg
Height x Width Height x Width Diagonal Inches

Format for data / video projection

4:3

138 x 180 cm	126 x 168 cm	83"	11
153 x 200 cm	143 x 190 cm	94"	13
183 x 240 cm	173 x 230 cm	113"	16
213 x 280 cm	203 x 270 cm	133"	19

Format for wide screen use

16:10

115 x 180 cm	105 x 168 cm	85"	11
129 x 200 cm	119 x 190 cm	88"	12
154 x 240 cm	144 x 230 cm	107"	16
179 x 280 cm	169 x 270 cm	125"	18

Housing dimensions
L1 mm L2 mm max. L3 mm

Gain

Ref.no.

1914	1734	1820	1.0	7-543653
2134	1954	2040	1.0	7-543654
2534	2354	2440	1.0	7-543656
2934	2754	2840	1.0	7-543658

1914	1734	1820	1.0	7-543712
2134	1954	2040	1.0	7-543713
2534	2354	2440	1.0	7-543714
2934	2754	2840	1.0	7-543753

PREMIUM manual projection screen



- Manual projection screen with spring mechanism
- Supplied in the most compact case
- Easy to mount on a wall or ceiling using the integrated mounting brackets on each end cap
- The screen locks into place at 11 cm intervals for flexible height adjustment. The intervals are at 15 cm for screen widths of 200 cm

- Matte white screen fabric
- Screen fabric is flame retardant
- Black border increases perceived clarity of the projected image
- Formats: square (1:1), video (4:3) and wide (16:9)

- Case colour is white; RAL 9016
- Sturdy construction
- Quality marks: CE

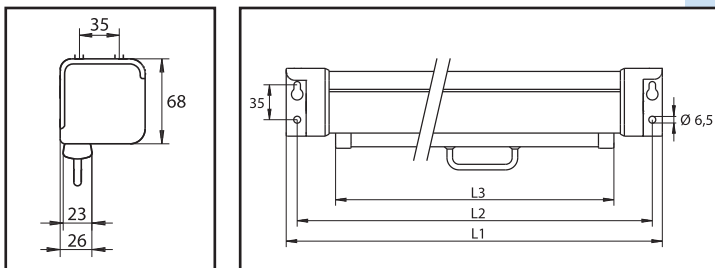

Screen dimension Height x Width	Viewing size Height x Width	Nominal Diagonal Inches	kg
------------------------------------	--------------------------------	----------------------------	----

Standard format

1:1

160 x 160 cm	151 x 151 cm	-	7
180 x 180 cm	173 x 173 cm	-	8
200 x 200 cm	195 x 195 cm	-	9

Format for data / video projection

4:3

Screen dimension	Viewing size	Nominal Diagonal	kg
123 x 160 cm	110 x 146 cm	72"	6
138 x 180 cm	126 x 168 cm	84"	7
153 x 200 cm	143 x 190 cm	100"	8

Format for wide screen / HDTV use

16:9

Screen dimension	Viewing size	Nominal Diagonal	kg
90 x 160 cm	82 x 146 cm	65"	6
102 x 180 cm	95 x 168 cm	82"	7
117 x 200 cm	107 x 190 cm	92"	8

Housing dimensions	Gain	Ref.no.
L1 mm	L2 mm	L3 mm

1718	1696	1620	1.0	7-540152
1918	1896	1820	1.0	7-540153
2138	2116	2040	1.0	7-540154

1718	1696	1620	1.0	7-540052
1918	1896	1820	1.0	7-540053
2138	2116	2040	1.0	7-540054

1718	1696	1620	1.0	7-540025
1918	1896	1820	1.0	7-540027
2138	2116	2040	1.0	7-540029

PROJECTION



ECONOMY manual projection screen

- Entry-level manual projection screen
- Particularly suitable for regular to light use
- Wall or ceiling attachment
- White steel screen housing with plastic end caps
- Easy to mount: fixing points on the end caps of the screen housing
- Smooth rolling and re-rolling of projection screen fabric
- The screen is equipped with an easy-to-use handgrip for adjusting the height and format of the screen
- Includes a user friendly pull-down rope which can be attached to the handgrip
- Black border increases perceived clarity of the projected image
- Comes complete with fittings for wall/ceiling attachment, pulling cord and mounting manual

- Matte white screen fabric
- Screen housing shape: octagon
- Colour of back of screen fabric: white
- Automatic stop
- Red stop sign on the screen fabric prevents the fabric from being pulled out too far



Recommended accessory:
Laser pointer LX 1 Ref.no. 7-575300

Format	Size	Black Border
1:1	Size up to 240 cm	3 cm left and right
1:1	Size bigger than 240 cm	5 cm left and right
4:3	Size up to 240 cm	3 cm left-right-bottom, 5 cm top
4:3	Size bigger than 240 cm	5 cm all four sides

Screen dimension
Height x Width

Viewing size
Height x Width

Standard format

160 x 160 cm	152 x 152 cm
180 x 180 cm	174 x 174 cm
200 x 200 cm	194 x 194 cm

1:1

Format for data / video projection

120 x 160 cm	111 x 148 cm
150 x 200 cm	143 x 190 cm
180 x 240 cm	173 x 230 cm

4:3

Viewing size
Inch (H x W x diagonal)

kg

Gain

Ref.no.

60" x 60"	6	1.0	7-544652
70" x 70"	8	1.0	7-544653
80" x 80"	10	1.0	7-544654

63" x 47" / 80"	6	1.0	7-544752
79" x 59" / 100"	8	1.0	7-544754
96" x 71" / 120"	12	1.0	7-544760



PROFESSIONAL mobile portable deluxe projection screen

- Lightweight, portable projection screen in video format sizes (floor screen)
- The flexible pneumatic tensioning arm makes it possible for the height to be adjusted infinitely and flexibly
- Supplied with an extra black lower border as standard for adjusting to the ideal viewing height
- The PROFESSIONAL mobile portable deluxe has two feet which are folded out when setting up to give it stability
- The case is made of aluminium with a subtle titanium-coloured finish

- Matte white high gain
- Screen fabric is flame retardant
- Black border increases perceived clarity of the projected image
- Very stable with two fold-away feet
- Flexible viewing-height adjustment via extended black border on the bottom
- Formats: video (4:3)

- Case colour is aluminium titanium
- Suitable for intensive portable use
- Sturdy construction
- Quality marks: CE

A = Bottom Surface (cm)
 B = Min. Height (cm)
 C = Max. Height (cm)

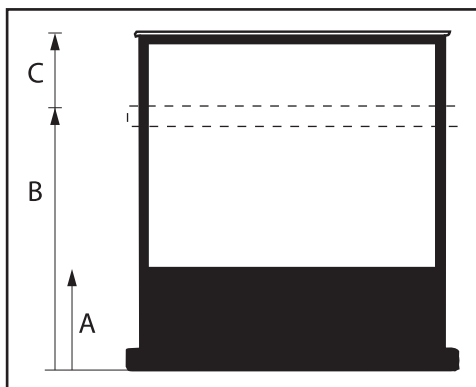

Screen dimension Height x Width	Viewing size Height x Width	Nominal Diagonal Inches	kg
------------------------------------	--------------------------------	----------------------------	----

Format for data / video projection

99 x 130 cm	91 x 122 cm	60"	6
130 x 170 cm	122 x 162 cm	80"	7
157 x 211 cm	119 x 199 cm	100"	8

4:3

Dimensions			Gain	Ref.no.
A cm	B cm	C cm		
104	100	204	2.2	7-531149
74	131	205	2.2	7-531152
88	160	248	2.2	7-531155

PROJECTION

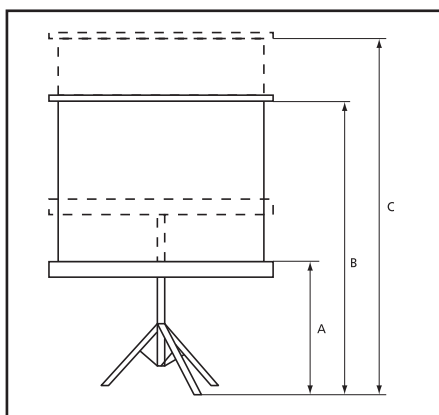

Screen dimension Height x Width	Viewing size Height x Width	Nominal Diagonal Inches	kg
------------------------------------	--------------------------------	----------------------------	----

Standard format

1:1

213 x 213 cm	207 x 207 cm	-	18
244 x 244 cm	238 x 238 cm	-	20

Format for data / video projection

4:3

115 x 152 cm	109 x 146 cm	72"	13
135 x 178 cm	127 x 172 cm	84"	15
162 x 213 cm	152 x 203 cm	100"	17
185 x 244 cm	175 x 234 cm	120"	19

PROFESSIONAL mobile projection screen

- Top quality projection screen on a tripod, well known for its stability and durability under intensive, portable use
- The PROFESSIONAL mobile has a very stable tripod made from square tubing and features a simple, foot-operated toe-release mechanism
- Special transport lock protects the screen fabric from damage
- Self-locking handle for optimum height adjustment and portability
- Integrated OHP bracket for keystone correction with a length of 40 cm

- Matte white screen fabric
- Screen fabric is flame retardant
- Black border increases perceived clarity of the projected image
- Tripod can easily be folded ready for storage
- Format (1:1 or 4:3) directly adjustable via hole design

- Case colour is black
- Suitable for intensive portable use
- User friendly features such as transport lock and self locking handle
- Sturdy construction
- Quality marks: CE

Housing dimensions			Gain	Ref.no.
A mm	B mm	C mm		

51	278	325	1.0	7-530655
51	307	325	1.0	7-530657

51	174	254	1.0	7-530725
51	185	300	1.0	7-530753
51	217	325	1.0	7-530755
51	239	325	1.0	7-530761



PREMIUM mobile projection screen

- Projection screen on a tripod
- The PREMIUM mobile has a stable tripod made from square tubing
- Special transport lock shields the screen fabric from damage
- Easy-to-operate handle for adjusting height and aspect ratios
- Light-weight, aluminium case with handle

- Matte white screen fabric
- Screen fabric is flame retardant
- Black border increases perceived clarity of the projected image
- Formats: square (1:1)

- Case colour is black
- Suitable for intensive portable use
- Sturdy construction
- Quality marks: CE

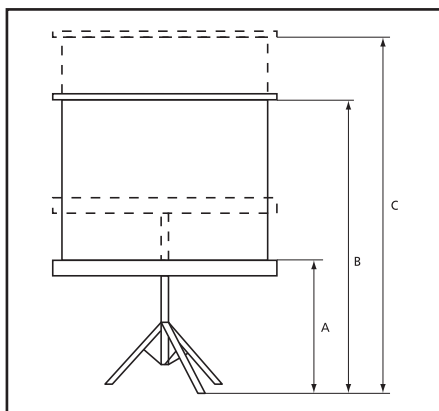

Screen dimension Viewing size
Height x Width Height x Width kg

Standard format

127 x 127 cm	121 x 121 cm	8
152 x 152 cm	146 x 146 cm	10
178 x 178 cm	172 x 172 cm	11

1:1

Housing dimensions
A cm B cm C cm

43	165	224
43	203	269
55	231	295

Gain

Ref.no.

1.0	7-531225
1.0	7-531250
1.0	7-531253

PROJECTION

ECONOMY mobile portable projection screen



- Entry-level portable projection screen (floor screen)
- Particularly suitable for regular to light use
- Specifically for mobile use: easily move your screen from one room to the other
- Height adjustable; screen height can be adjusted with the telescopic rod
- Integrated telescopic rod storage area
- The V-shaped screen housing serves as a stable base
- Quick and easy set-up
- Useful and user-friendly carry handle
- Carry handle is integrated in the screen case; there is no need for a separate carry bag
- Matte white screen fabric
- Black border increases perceived clarity of the projected image
- Comes complete with integrated carry handle and mounting manual
- Colour of back of screen fabric: grey
- Maximum height: ca. 190 cm

Format	Size	Black Border
4:3	All	3 cm left-right-top, 65 cm bottom

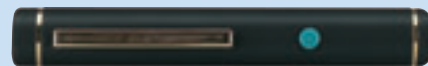

Recommended accessory:
Laser pointer LX 1 Ref.no. 7-575300

Screen dimension Height x Width	Viewing size Height x Width
------------------------------------	--------------------------------

Format for data / video projection

90 x 120 cm	87 x 116 cm
120 x 160 cm	117 x 156 cm

4:3

Viewing size Inch (H x W x diagonal)	kg	Gain	Ref.no.
47" x 35" / 80"	11	1.0	7-531349
63" x 47" / 80"	14	1.0	7-531330



ECONOMY mobile projection screen

- Entry-level mobile tripod projection screen
- Particularly suitable for regular to light use
- Specifically for mobile use: easily move your screen from one room to another
- User-friendly features such as transport lock
- Black powder-coated screen housing
- Height adjustable; screen height can be adjusted with the telescopic rod
- Quick and easy set-up
- Black tripod fold-in frame
- Black border increases perceived clarity of the projected image
- Comes complete with mounting manual

- Matte white screen fabric
- Screen fabric backside colour: black
- Maximum height: approx. 235 cm
- Steel stand

Format	Size	Black Border
1:1	All	No black border
4:3	All	3 cm left and right

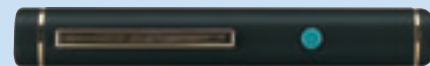

Recommended accessory:
Laser pointer LX 1 Ref.no. 7-575300

	Screen dimension Height x Width	Viewing size Height x Width	Inch (H x W x diagonal)	kg	Gain	Ref.no.
1:1	Standard format					
	160 x 160 cm	160 x 160 cm	60" x 60"	7	1.0	7-531452
	180 x 180 cm	180 x 180 cm	70" x 70"	9	1.0	7-531453
	200 x 200 cm	200 x 200 cm	80" x 80"	10	1.0	7-531454
4:3	Format for data / video projection					
	120 x 160 cm	115.5 x 154 cm	63" x 47"/ 80"	7	1.0	7-531552
	150 x 200 cm	145.5 x 194 cm	79" x 59"/ 100"	10	1.0	7-531554
	180 x 240 cm	175.5 x 234 cm	87" x 65"/ 110"	12	1.0	7-531560

PROJECTION

Accessories for projection screens

Ceiling brackets

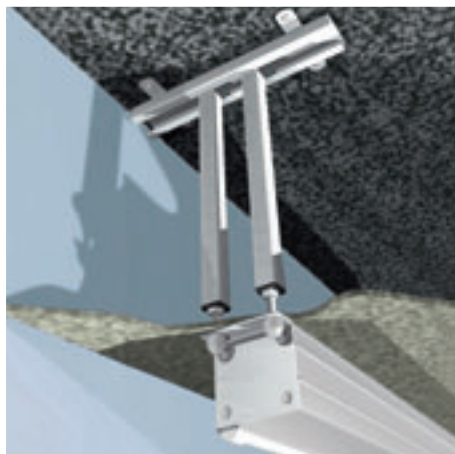

For installation of a projection screen in a high room or under a recessed ceiling, special ceiling brackets are available. The ceiling brackets measure 100 cm (length) but can be shortened as needed.

Ceiling brackets for PROFESSIONAL and PREMIUM – M6 100 cm

Suitable for:

- PREMIUM (RF) electrical
- PROFESSIONAL (CSR) manual

Ceiling brackets	Length	Ref.no.
PROFESSIONAL and PREMIUM	100 cm	7-554500

Ceiling brackets for PROFESSIONAL – M8 100 cm

Suitable for:

- PROFESSIONAL RF electrical (built-in)

Ceiling brackets	Length	Ref.no.
PROFESSIONAL	100 cm	7-555200



Wall brackets

In certain cases, it might be necessary to move the projection screen away from the wall.

For example:

if a painting is hanging where the projection screen needs to be.

For example:

if for overhead projection the projection screen must be placed on a tiltable angle to prevent distortion of the image.

Wall brackets	Length	Ref.no.
PROFESSIONAL and PREMIUM	75 cm	7-555100
PROFESSIONAL and PREMIUM	30 cm	7-545400

Other accessories available on request.

Laser pointer LX 3



Laserpointer	Length	Laser class	Weight incl. batteries	Ref.no.
LX 3 green	15 cm	2	71 g	7-575600

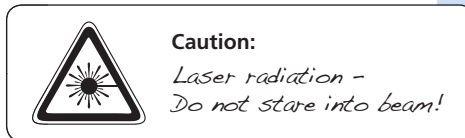

The eye is 20 times more sensitive to a green colour than a red colour. Therefore a green laser pointer is particularly suitable for use in a daylight situation or on a brightly lit screen. The green dot is very bright and piercing and has a very long range.
For use in an office, classroom or conference environment.

- Best laser pointer tool for high brightness screens and big display presentations
- Laser pointer with a green dot, Ø 1.4 cm
- By pushing the button the green laser dot is activated
- Green laser beam; high visibility (twenty times higher than a red laser beam)
- Silver metal casing
- Practical pen-clip
- Soft structured grip zone
- Range: 200 m
- Laser class 2, power < 1 mW
- CE-approved
- Certified to standard EN 60825-1
- Comes complete with case, 2 AAA batteries and a user manual

Laser pointer LX 1, LX 2 and LX 4



Laserpointer	Length	Laser class	Weight incl. batteries	Ref.no.
LX 1	10 cm	2	60 g	7-575300
LX 2	14 cm	2	56 g	7-575500
LX 4	14 cm	2	54 g	7-575700

- Power: <1 mW
- Red laser dot, diameter approx. 4 mm
- Certified to standard EN 60825-1
- Range: 100 m
- CE tested
- Comes complete with case and batteries

Laserpointer LX 1:

- Black metal casing
- Green on / off button
- Handy size
- Battery: (N) battery SUM5R1



Laserpointer LX 2:

- Silver metal casing
- Red on / off button
- Sturdy
- Battery: (AAA) battery SUM4R03

Laserpointer LX 4:

- Silver metal casing
- Red on / off button
- Red laser dot: can be turned into an arrow by twisting the laser head
- Battery: (AAA) battery SUM4R03



PLANNING

Managing is a question of looking ahead. Once you have determined your strategy, you must plan carefully and realistically. It is then a matter of keeping all those involved thoroughly informed about the objectives.

To realise your goals it is important to continuously visualise your planning in an up-to-date way, offering insight through overview.





Choose your ideal planner

STEP 1

Answer these three questions:

For what length of time do I need to plan?

How many people / objects / events do I want to display?

How much wall space do I have at my disposal?

STEP 2

Find the best planner to suit your needs:

Match your answers to the three questions with the table below, and place a cross in the appropriate right-hand box. Deciding which planner to buy should then be easy.

Division	Capacity	Size H x W	Description	Ref.no.	Page	
1 week						
7 days	5	60 x 90 cm	General planner	7-418000	107	<input type="checkbox"/>
7 days	25	90 x 120 cm	Activity planner	7-409000	103	<input type="checkbox"/>
7 days	1	60 x 90 cm	Week planner	7-490000	109	<input type="checkbox"/>
7 days	5	60 x 90 cm	Multi purpose planner	7-490500	109	<input type="checkbox"/>
5 weeks						
7 days	5	90 x 120 cm	Activity planner	7-409000	103	<input type="checkbox"/>
7 days	1	60 x 90 cm	Multi purpose planner	7-490500	109	<input type="checkbox"/>
35 days / 24 h	1	60 x 90 cm	Week planner	7-413500	106	<input type="checkbox"/>
7 days	1	60 x 90 cm	General planner	7-418000	107	<input type="checkbox"/>
25 days	1	60 x 90 cm	Month planner	7-489500	108	<input type="checkbox"/>
35 days	20 / 10*	60 x 90 cm	Week planner	7-413500	106	<input type="checkbox"/>
35 days	40	60 x 90 cm	Multi purpose planner	7-410800	104	<input type="checkbox"/>
½ year						
27 weeks	60	90 x 120 cm	Year planner (7-days week)	7-406000	102	<input type="checkbox"/>
27 weeks	66	90 x 120 cm	Year planner	7-415000	107	<input type="checkbox"/>
1 year						
365 days	1	60 x 90 cm	Year planner (compact)	7-411000	104	<input type="checkbox"/>
365 days	1	60 x 90 cm	Year planner	7-412000	105	<input type="checkbox"/>
365 days	20	60 x 90 cm	Project planner	7-414000	106	<input type="checkbox"/>
365 days	30 / 15*	100 x 200 cm	Year planner (6-month format)	7-405500	101	<input type="checkbox"/>
365 days	30	50 x 150 cm	Year planner (5-days week)	7-404100	99	<input type="checkbox"/>
365 days	30	90 x 120 cm	Year planner (7-days week)	7-406000	102	<input type="checkbox"/>
365 days	33	90 x 120 cm	Year planner	7-415000	107	<input type="checkbox"/>
365 days	40 / 20*	60 x 90 cm	Year planner (compact)	7-413000	105	<input type="checkbox"/>
365 days	50	75 x 150 cm	Year planner (5-days week)	7-404200	99	<input type="checkbox"/>
365 days	75	100 x 150 cm	Year planner (5-days week)	7-404300	99	<input type="checkbox"/>
365 days	75	100 x 200 cm	Year planner (7-days week)	7-405000	100	<input type="checkbox"/>
365 days	1	90 x 120 cm	Year planner	7-400000	98	<input type="checkbox"/>
365 days	1	60 x 90 cm	Year planner	7-489000	108	<input type="checkbox"/>

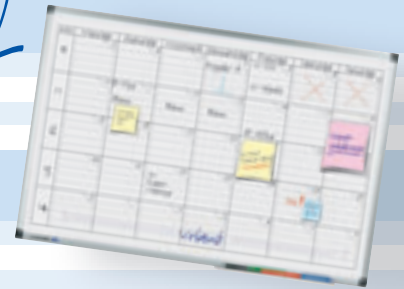

If any of our planners do not meet your requirements, please contact us.

* Figures in brackets denote the capacity when using double spacing

PLANNING

PROFESSIONAL year planner 365 days

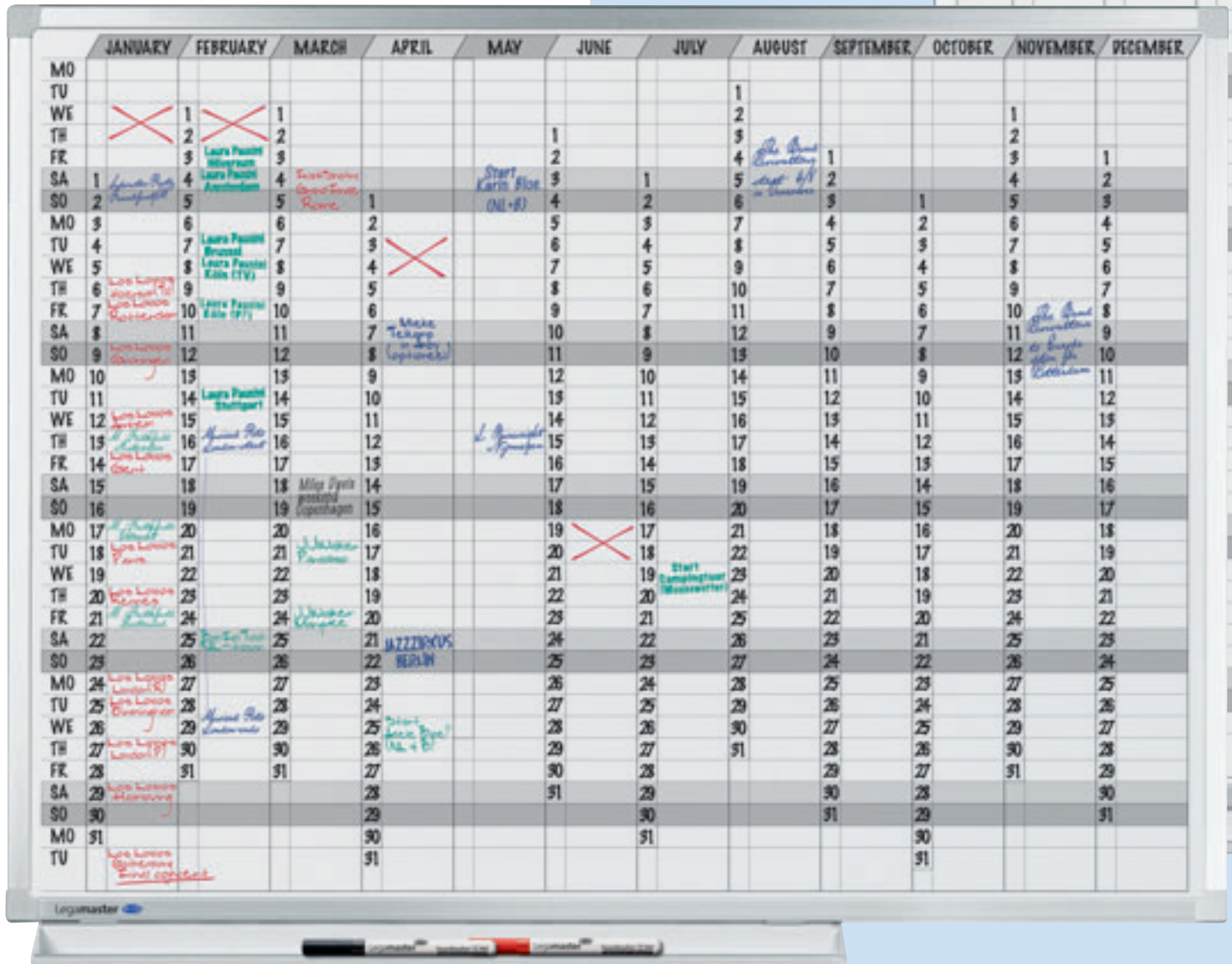

- High quality planner with enamel writing surface
- Fill out months and days and visualise an entire year
- Entire year at a glance
- Anodised aluminium frame
- Light-weight honeycomb board structure
- Practical design
- Magnetic date strips to update each year
- Magnetic; suitable for writing on with dry wipe board markers
- Enamel surface (double fired at 800°C)
- Acid and scratch resistant
- Write on / dry wipe surface is guaranteed for 25 years when used in combination with Legamaster accessories
- Comes complete with fixing kit, marker tray, date strips and one board marker

Height x Width Ref.no.
90 x 120 cm 7-400000

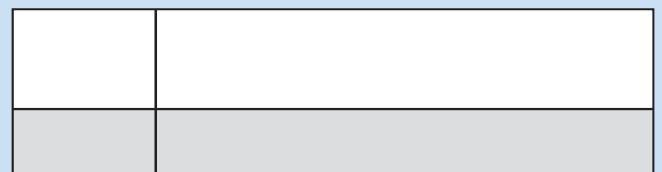

■ Grid size: H 22 x W 70 mm



Recommended accessory:
Planning set 1 Ref.no. 7-435100



PROFESSIONAL year planner 12 month format

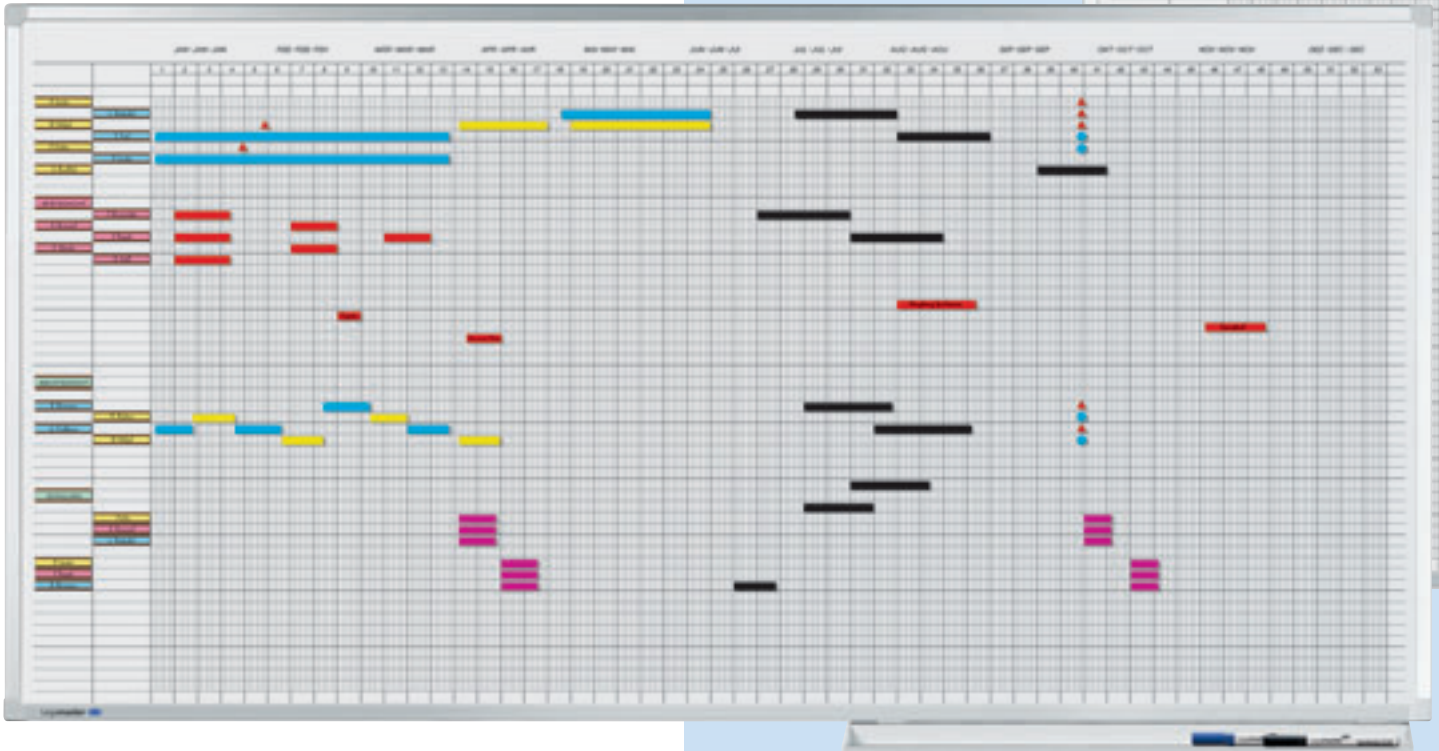

- High quality planner with enamel writing surface
- Breaks down into divisions of 5 day weeks
- Entire year at a glance
- Anodised aluminium frame
- Light-weight honeycomb board structure
- Ideal for staff planning
- Magnetic; suitable for writing on with dry wipe board markers
- Enamel surface (double fired at 800°C)
- Acid and scratch resistant
- Write on / dry wipe surface is guaranteed for 25 years when used in combination with Legamaster accessories
- Comes complete with fixing kit, marker tray, date strip set 2 and one board marker

Height x Width	For	Ref.no.
50 x 150 cm	30 people / events	7-404100
75 x 150 cm	50 people / events	7-404200
100 x 150 cm	75 people / events	7-404300

Sliding index

- For a detailed overview on large planners
- Easy and simple to use
- Recommended for planners of 100 cm height and at least 150 cm width particularly Ref.no. 7-404300
- Permanent lines for up to 75 people / objects / events
- Magnetic surface
- Write-on / dry-wipe surface using board markers
- Specially developed roller-spring system: slides across the board using the upper tracking of the PROFESSIONAL frame, ensuring optimum grip when moved sideways

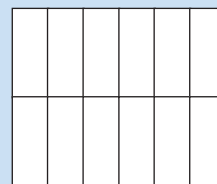

Shown actual size
 ■ Grid size approx. H 12 x W 5 mm
 ■ Index column size approx. 2 x H 12 x W 60 mm

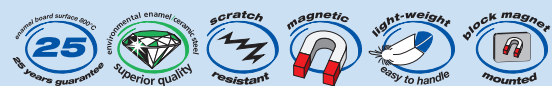

Recommended accessories:
 Planning set 2 Ref.no. 7-435200
 Planning set 3 Ref.no. 7-435300

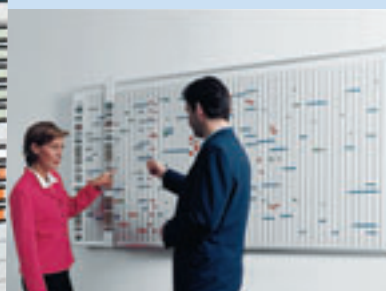

- Ruled lines every 12 mm
- H 101.7 x W 7 cm
- Detachable magnetic sheeting

Ref.no. 7-430500

PLANNING

PROFESSIONAL year planner 75 items

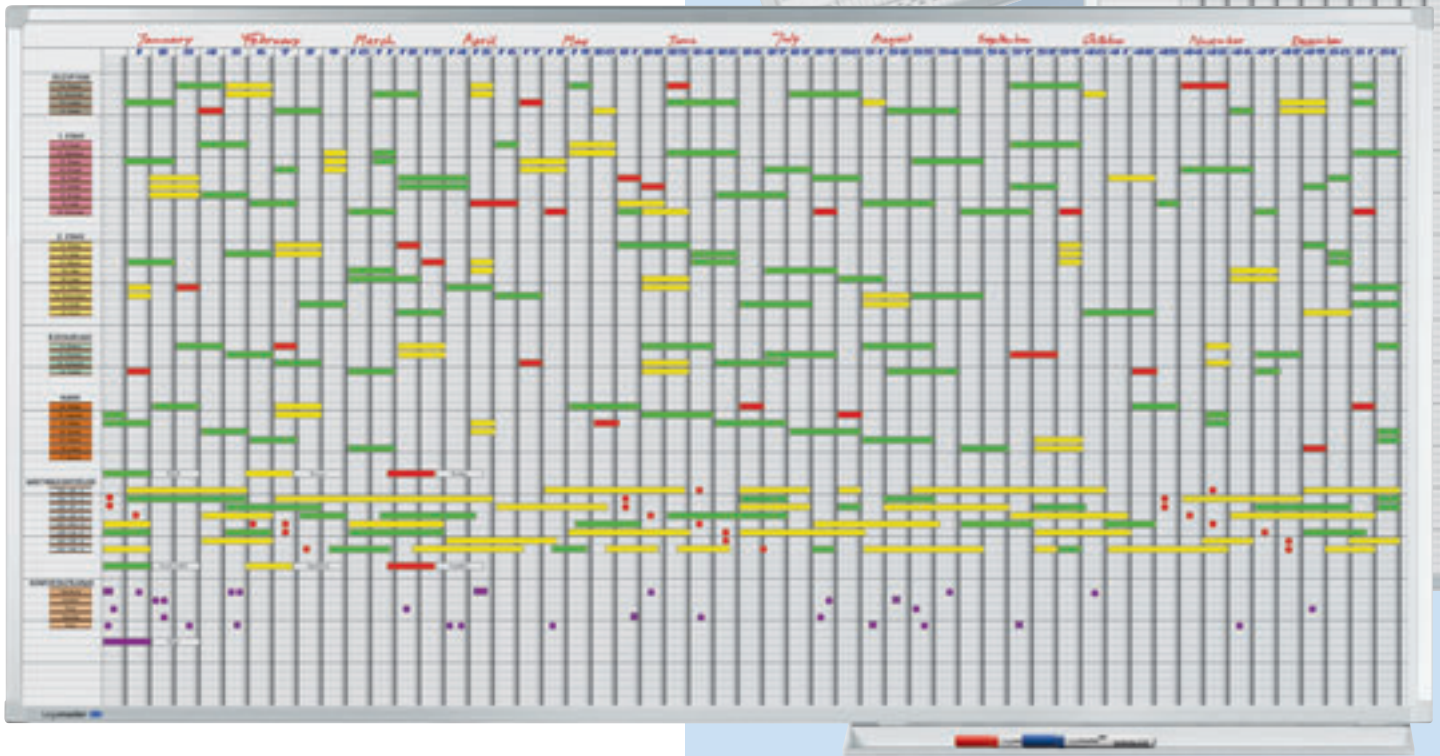

- High quality planner with enamel writing surface
- Breaks down into 7 day week divisions and 365 day grids
- Suitable for 75 people / events / objects
- Entire year at a glance
- Anodised aluminium frame
- Light-weight honeycomb board structure
- Weekends shaded in grey
- Contents include: date strip set 3, showing names of the months (in five languages), calendar week numbers and day numbers (1-7)
- The accessories included mean you can start from any month
- Magnetic; suitable for writing on with dry wipe board markers
- Enamel surface (double fired at 800°C)
- Acid and scratch resistant
- Write on / dry wipe surface is guaranteed for 25 years when used in combination with Legamaster accessories
- Comes complete with fixing kit, marker tray, date strip set 3 and one board marker

Height x Width	Ref.no.
100 x 200 cm	7-405000

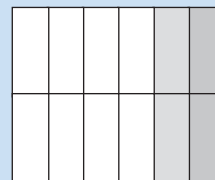

Shown actual size

- Grid size approx. H 12 x W 5 mm
- Index column size approx. H 12 x W 90 mm



Recommended accessory:
Planning set 3 Ref.no. 7-435300



PROFESSIONAL year planner 30 items

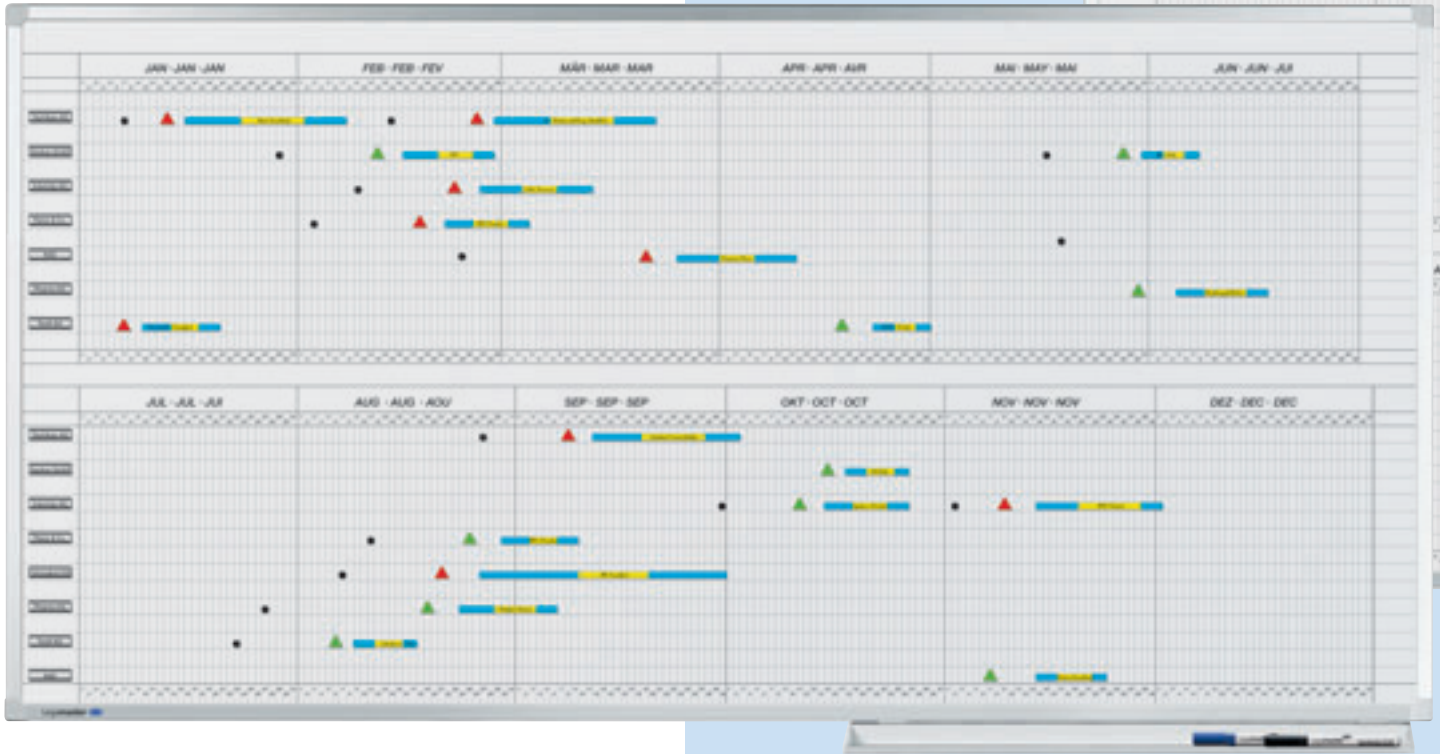

- High quality planner with enamel writing surface
- Breaks down into one month divisions and 365 day grids
- Suitable for 30 people / events / objects (or up to 15 people / events / projects if using double line spacing)
- Anodised aluminium frame
- Light-weight honeycomb board structure
- Combines long range planning with large day grids
- Magnetic; suitable for writing on with dry wipe board markers
- Enamel surface (double fired at 800°C)
- Acid and scratch resistant
- Write on / dry wipe surface is guaranteed for 25 years when used in combination with Legamaster accessories
- Comes complete with fixing kit, marker tray and one board marker

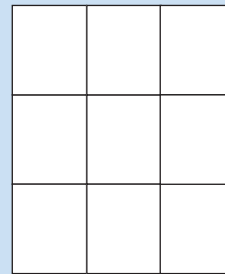

Shown actual size

- Grid size approx. H 12 x W 10 mm (approx. H 24 x W 10 mm in double spacing)
- Index column approx. H 12 x 80 mm (approx. H 24 x W 80 mm in double spacing)



Height x Width Ref.no.
100 x 200 cm 7-405500

Recommended accessory:
Planning set 3 Ref.no. 7-435300



*Choose your
ideal planner,
see page 97.*



PLANNING

PROFESSIONAL year planner 6 month format

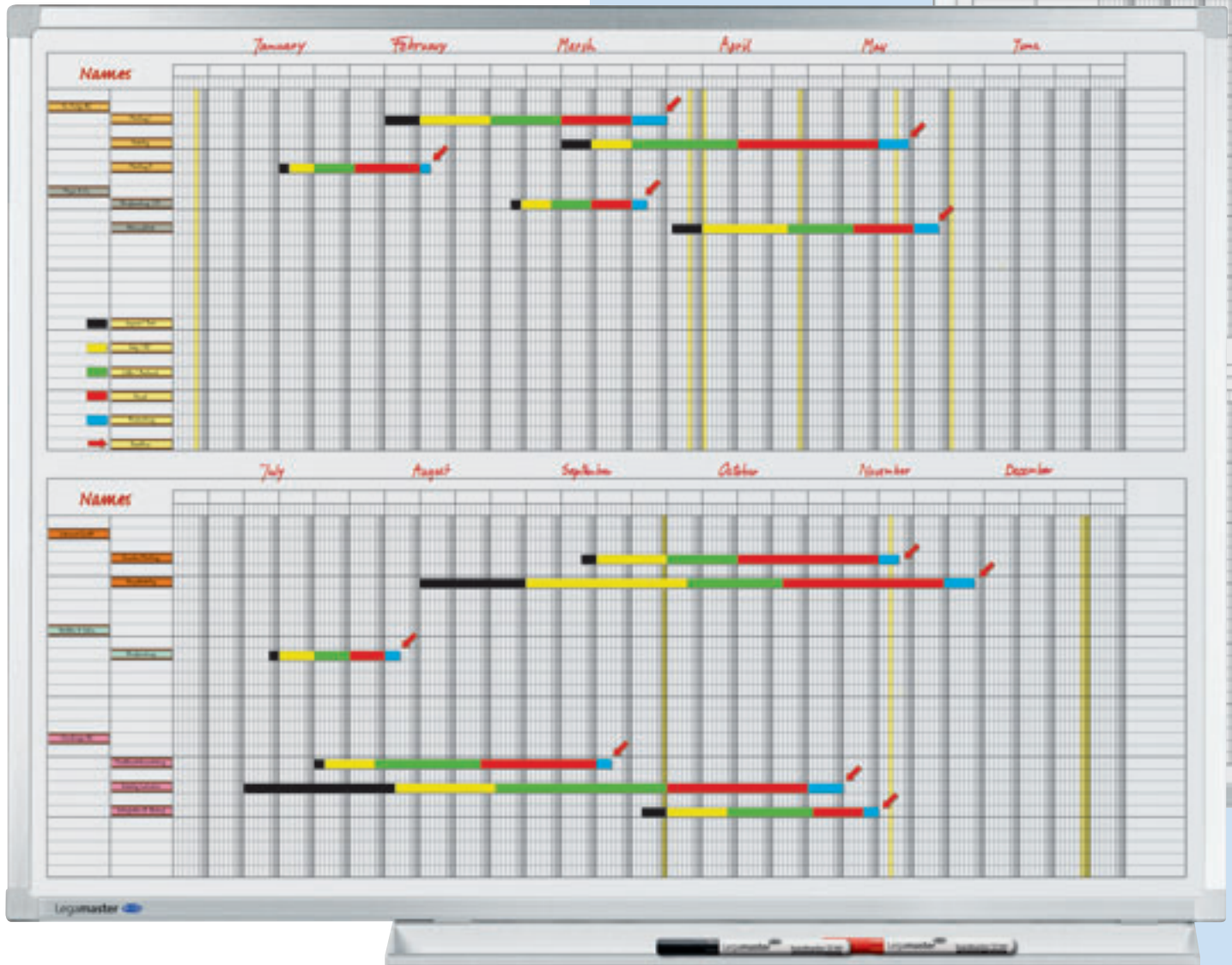

- High quality planner with enamel writing surface
- Year planner in six month format
- Breaks down into 7 day week divisions and 365 day grids
- Suitable for up to 60 people / events / objects using the six month format
- Suitable for up to 30 people / events / objects using the 12 month format
- Anodised aluminium frame
- Light-weight honeycomb board structure
- Weekends shaded in grey
- Contents include: set of date strips 1 showing names of the months (in five languages), calendar week numbers 12 month strips (dates 1-31)
- The accessories included enable you to start planning from any month
- Magnetic; suitable for writing on with dry wipe board markers
- Enamel surface (double fired at 800°C)
- Acid and scratch resistant
- Write on / dry wipe surface is guaranteed for 25 years when used in combination with Legamaster accessories
- Comes complete with fixing kit, marker tray, date strip set 1 and one board marker

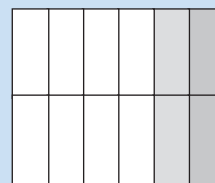

Shown actual size

- Grid size approx. H 12 x W 5 mm
- Index column approx. 2 x H 12 x W 60 mm

Height x Width

Ref.no.

90 x 120 cm

7-406000



Recommended accessories:
 Planning set 2: for up to 40 people
 Ref.no. 7-435200
 Planning set 3: for up to 75 people
 Ref.no. 7-435300
 Set of date strips 1 Ref.no. 7-431100
 Date line Ref.no. 7-430000



PROFESSIONAL activity planner

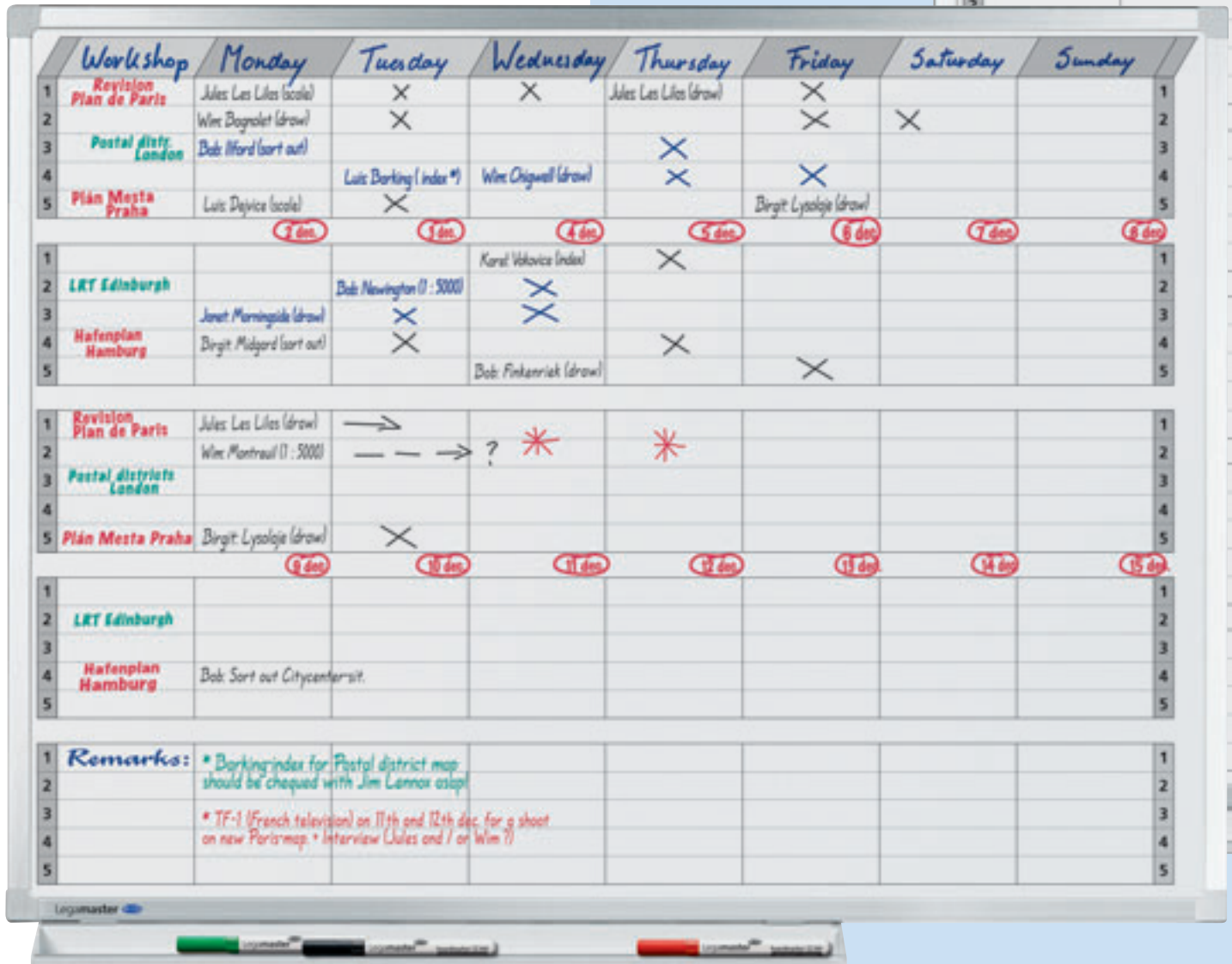

- High quality planner with enamel writing surface
- Versatile write-on planner for a wide variety of plans
- 8 columns for projects and days of the week from Monday to Sunday
- 5 x blocks of five lines
- Anodised aluminium frame
- Light-weight honeycomb board structure
- Magnetic; suitable for writing on with dry wipe board markers
- Enamel surface (double fired at 800°C)
- Acid and scratch resistant
- Write on / dry wipe surface is guaranteed for 25 years when used in combination with Legamaster accessories
- Comes complete with fixing kit, marker tray and one board marker

Height x Width Ref.no.
90 x 120 cm 7-409000

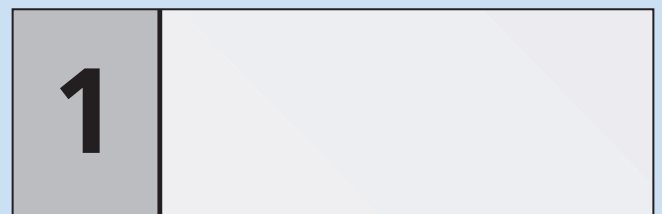

Shown actual size

■ Grid size: H 28 x W 135 mm



Recommended accessory:
Planning set 1 Ref.no. 7-435100



PLANNING

PREMIUM^{PLUS} multi purpose planner

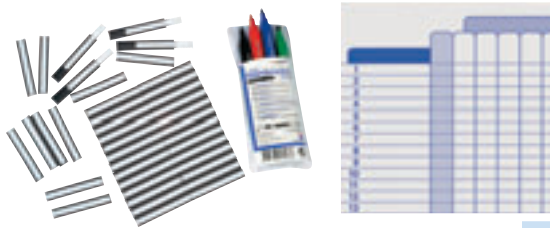
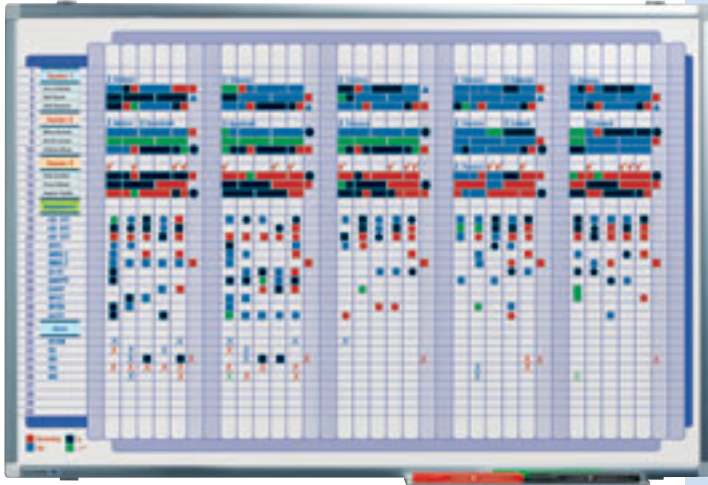

- High quality planner with enamel writing surface
- Can be used as week planner with days across the top and projects down the side
- For up to 40 projects, staff members, events or tasks
- Weekends are marked in a different colour
- Anodised aluminium frame
- Magnetic; suitable for writing on with dry wipe board markers
- Grid size H 1.1 x W 2.1 cm
- Index column size H 1.1 x W 6.7 cm
- High quality, scratch resistant enamel surface
- Includes accessory set
 - TZ 111 / set of 4 board markers
 - 40 label holders (10 x 60 mm) with white inserts
- Comes complete with marker tray, accessory set and fixing kit

Height x Width Ref.no.
60 x 90 cm 7-410800



PREMIUM year planner horizontal

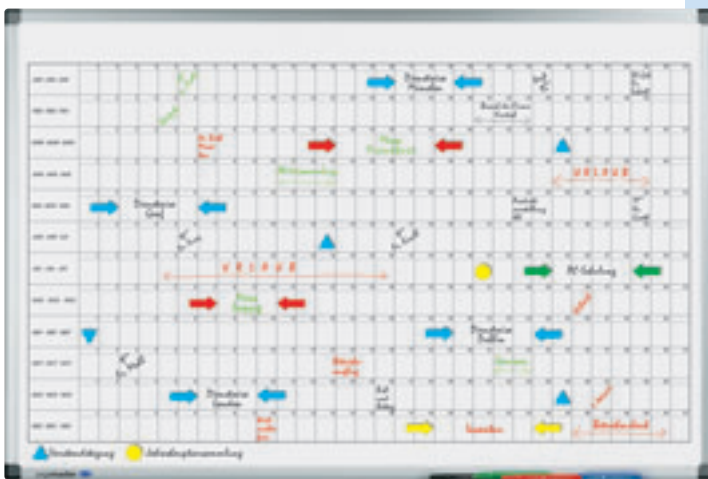

- Months can be written down the side (calendar style)
- Ideal as a personal planner
- Anodised aluminium frame
- Magnetic; suitable for writing on with dry wipe board markers
- Special UV hardened surface
- 30 cm marker tray
- Includes accessory set
 - TZ 111 / set of 4 board markers
 - 1 set of assorted magnetic symbols and shapes (20 mm)
- Comes complete with marker tray, accessory set and fixing kit



Shown actual size
■ Day grids approx. H 42 x W 25 mm

Height x Width Ref.no.
60 x 90 cm 7-411000



Recommended accessory:
Planning set 1 Ref.no. 7-435100

PREMIUM year planner vertical

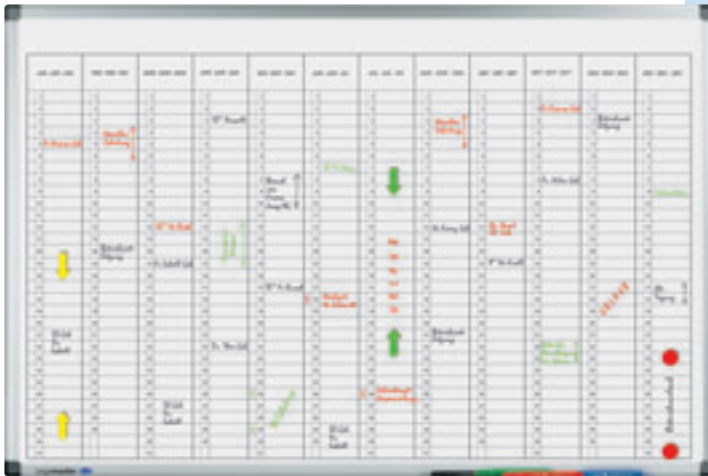

- Ideal as personal planner
- Anodised aluminium frame
- Magnetic; suitable for writing on with dry wipe board markers
- Special UV hardened surface
- 30 cm marker tray
- Includes accessory set
 - TZ 111 / set of 4 board markers
 - 1 set of assorted magnetic symbols and shapes (10 mm)
- Comes complete with marker tray, accessory set and fixing kit

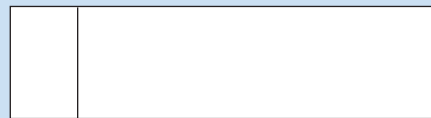

Shown actual size

- Day grids approx. H 15 x W 50 mm



Height x Width

60 x 90 cm

Ref.no.

7-412000



Recommended accessory:
Planning set 1 Ref.no. 7-435100

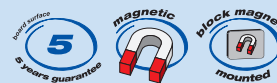

PREMIUM year planner 53 weeks

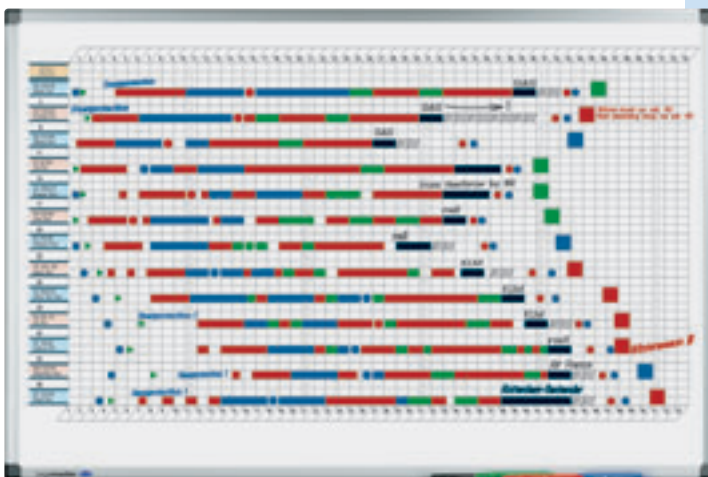

- Annual overview
- Year planner in 53 week format
- Anodised aluminium frame
- Magnetic; suitable for writing on with dry wipe board markers
- Special UV hardened surface
- 30 cm marker tray
- Includes accessory set
 - TZ 111 / set of 4 board markers
 - 40 label holders (10 x 60 mm) with white inserts
- Comes complete with marker tray, accessory set and fixing kit

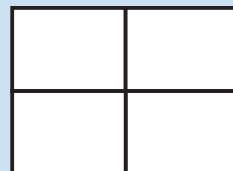

Shown actual size

- Grid size approx. H 11 x W 15 mm
- Index column size H 11 x W 60 mm

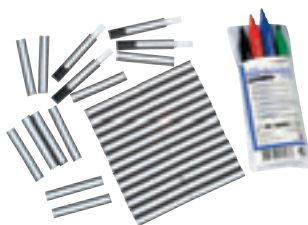

Height x Width

60 x 90 cm

Ref.no.

7-413000



Recommended accessories:
Planning set 2 Ref.no. 7-435200
Planning set 3 Ref.no. 7-435300

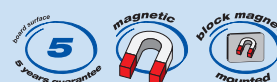

PLANNING

PREMIUM week planner 35 days

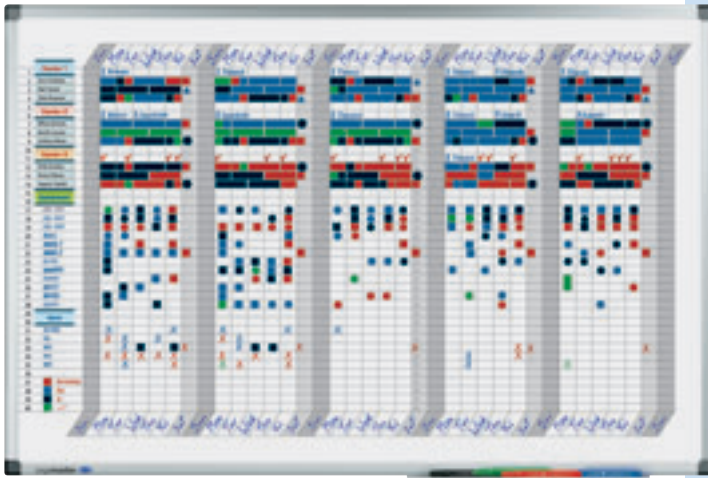

- Week planner broken down into 35 day blocks
- Ideal for planning work schedules
- Anodised aluminium frame
- Magnetic; suitable for writing on with dry wipe board markers
- Special UV hardened surface
- 30 cm marker tray
- Includes accessory set
 - TZ 111 / set of 4 board markers
 - 40 label holders (10 x 60 mm) with white inserts
- Comes complete with marker tray, accessory set and fixing kit

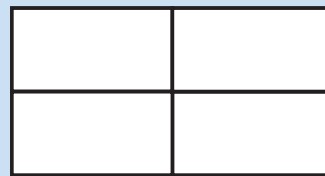

Shown actual size

- Grid size approx. H 11 x W 21 mm
- Index column size H 11 x W 80 mm

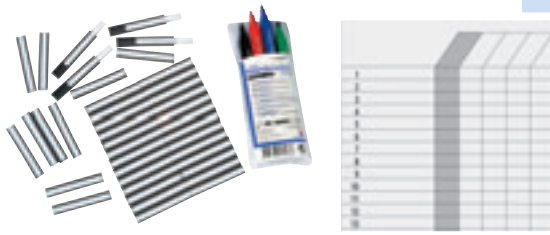

Height x Width Ref.no.
60 x 90 cm 7-413500



Recommended accessory:
Planning set 1 Ref.no. 7-435100

PREMIUM project planner

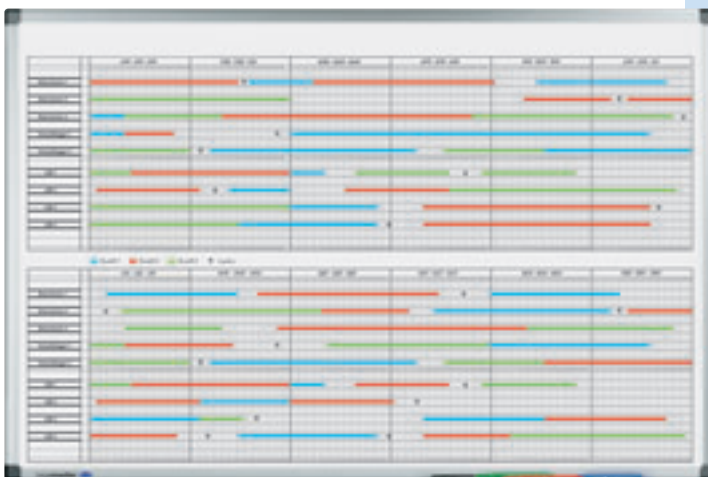

- Year planner in 2 x 6 month format
- For up to 20 people / objects / events
- Anodised aluminium frame
- Magnetic; suitable for writing on with dry wipe board markers
- Special UV hardened surface
- 30 cm marker tray
- Includes accessory set
 - TZ 111 / set of 4 board markers
 - 40 label holders (10 x 60 mm) with white inserts
- Comes complete with marker tray, accessory set and fixing kit

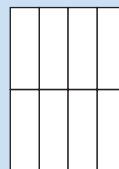

Shown actual size

- Day grids approx. H 11 x W 4 mm



Height x Width Ref.no.
60 x 90 cm 7-414000



Recommended accessories:
Planning set 2 Ref.no. 7-435200
Planning set 3 Ref.no. 7-435300

PREMIUM general planner

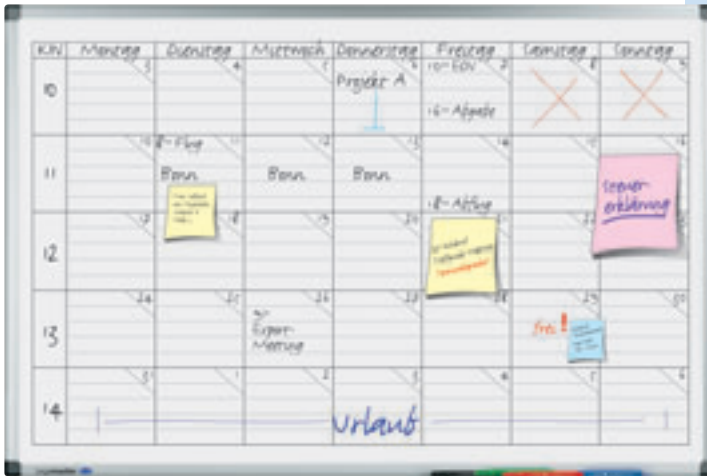

- Planning to your choice
- Week planner for up to 5 people / projects or for 1 person for a 5 week period
- Anodised aluminium frame
- Magnetic; suitable for writing on with dry wipe board markers
- Special UV hardened surface
- 30 cm marker tray
- Includes accessory set
 - TZ 111 / set of 4 board markers
 - 8 magnets (diam. 20 mm)
- Comes complete with marker tray, accessory set and fixing kit

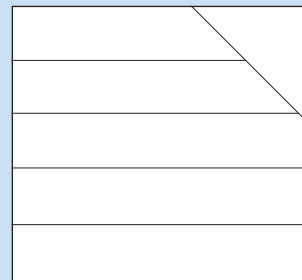

Scale: 1:3

- Day grids approx. H 11 x W 120 mm

Height x Width

Ref.no.

60 x 90 cm

7-418000

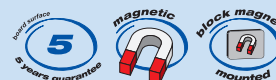

Recommended accessories:
 Planning set 2 Ref.no. 7-435200
 Planning set 3 Ref.no. 7-435300

PREMIUM year planner 6 month format

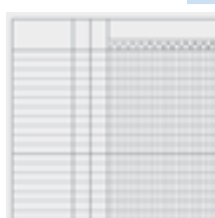
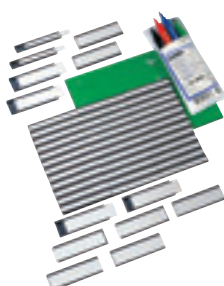
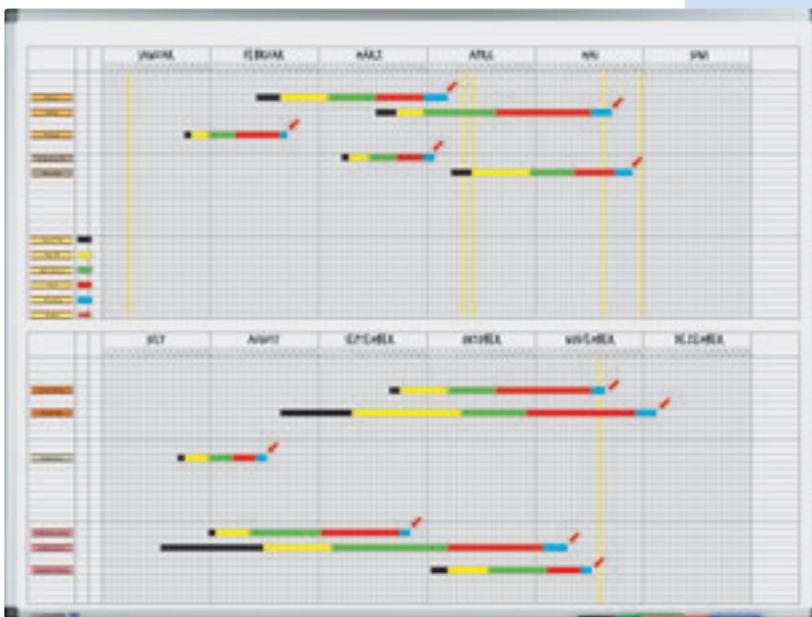

- Annual overview
- Year planner in 2 x 6 month format
- Division into 365 day grids
- Up to 33 people / objects / events when used as 12 month planner
- Up to 66 people / objects / events when used as 6 month planner
- Planning can start from any month
- Anodised aluminium frame
- Magnetic; suitable for writing on with dry wipe board markers
- Special UV hardened surface
- 30 cm marker tray
- Includes accessory set
 - TZ 111 / set of 4 board markers
 - 72 label holders (10 x 60 mm) with white inserts
 - 1 set of assorted magnetic symbols and shapes (10 mm)
- Comes complete with marker tray, accessory set and fixing kit

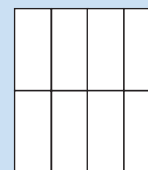

Shown actual size

- Grid size approx. H 11 x W 5 mm
- Index column size approx. H 11 x W 70 mm

Height x Width

Ref.no.

90 x 120 cm

7-415000

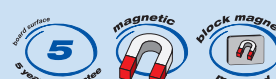

Recommended accessories:
 Planning set 2 Ref.no. 7-435200
 Planning set 3 Ref.no. 7-435300

PLANNING

ACCENTS Linear planners – Cool year planner

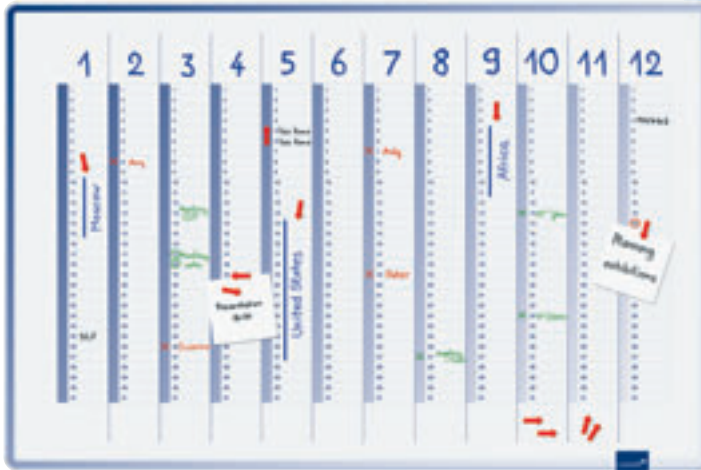

- Year planner with months across the top
- Months are not preprinted
- Grid size: H 13 x W 39 mm
- Lacquered steel surface with special coating
- Planner print with a gradient from dark to light colour
- Suitable for writing on with dry wipe board markers (alcohol based ink)
- Wall mount with L-hooks
- Comes complete with accessory set:
 - TZ 111 / set of 4 board markers
 - Magnetic symbols
- Design frame with plastic corner caps
- Also available: ACCENTS Linear whiteboards
- Weight: approx. 5 kg/m²
- Comes complete with fixing materials, marker tray and an accessory set

Height x Width	Ref.no.
60 x 90 cm	7-489000*



ACCENTS Linear planners – Cool month planner



- Month planner
- Months are not preprinted
- Grid size: H 91 x W 104 mm
- Lacquered steel surface with special coating
- Planner print with a gradient from dark to light colour
- Suitable for writing on with dry wipe board markers (alcohol based ink)
- Wall mount with L-hooks
- Comes complete with accessory set:
 - TZ 111 / set of 4 board markers
 - Magnetic symbols
- Design frame with plastic corner caps
- Also available: ACCENTS Linear whiteboards
- Weight: approx. 5 kg/m²
- Comes complete with fixing materials, marker tray and an accessory set

Height x Width	Ref.no.
60 x 90 cm	7-489500*



* Also available in cash&carry packaging

PLANNING

Divider tape for planboards

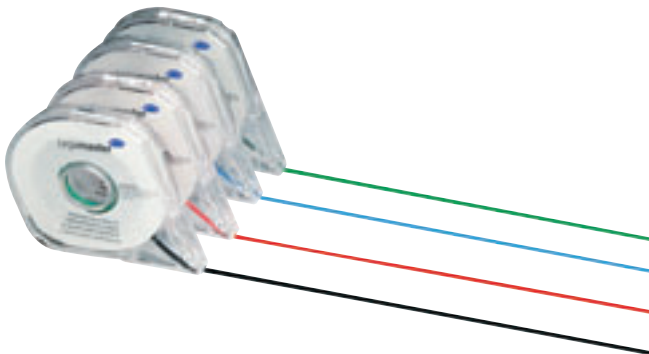

- A quick and accurate way of dividing columns and rows
- Self-adhesive, available in available in black, red, blue and green
- Useful accessory for grid and planning boards
- Just add the right colour code to Ref.no.

Size	Ref.no.
1.0 mm x 16 m	7-4331xx
2.5 mm x 16 m	7-4332xx
3.0 mm x 8 m	7-4333xx

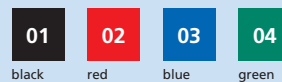

Date strip sets

Date strip set 1:

- For year planner
Ref.no. 7-406000
- Breaks down into 7 day week divisions and 365 day grids using the six month format



Ref.no. 7-431100

Date strip set 2:

- For year planner
Ref.no. 7-404100,
Ref.no. 7-404200,
Ref.no. 7-404300
- Breaks down into 5 day week divisions
- This set covers the years 2012 up to and including 2014



Ref.no. 7-431200

Date strip set 3:

- For year planner
Ref.no. 7-405000
- Breaks down into 7 day week divisions and 365 day grids



Ref.no. 7-431300

- Contents:
 - 12 month strips (dates 1-31), alternating in blue and green
 - Calendar week numbers 1-53
 - Names of the months in five languages: English, German, Dutch, French and Swedish

- Contents:
 - Strips with 12 month dates (1-31); applicable for specifically three years
 - 5-day week strips (1st letter of the days: M-F); applicable for any week and month. The week strips are delivered in English, German, Dutch, French and Swedish

- Contents:
 - 12 month indicators (January...etc.) in English, German, Dutch, French and Swedish
 - Strips with 12 month dates (1-31); applicable for any year
 - Calendar week numbers (1-53)
 - 7-day week strips (1st letter of the days: M-F); applicable for any week and month. The week strips are delivered in English, German, Dutch, French and Swedish

Date line



- Marks the day's date
- Length adjustable to fit all board sizes
- Magnetic date line for unlimited use on all magnetic boards

Ref.no. 7-430000



Planning sets



Planning set 1:

- For personal planning
- Contents:
 - 1 wallet of TZ 140 / set of 4 board markers, assorted
 - 1 OHP pen edding 152 M (black)
 - 12 magnetic strips (10 x 300 mm)
3 each in red, blue, green and yellow
 - 120 assorted magnetic symbols (20 mm)
30 each in red, blue, green and yellow

Ref.no. 7-435100



*Essential equipment
for your planboard.*



Planning set 2:

- For up to 40 people / events / projects
- Contents:
 - 1 wallet of TZ 140 / set of 4 board markers, assorted
 - 1 OHP pen edding 152 M (black)
 - 12 magnetic strips (10 x 300 mm)
3 each in red, blue, green and yellow
 - 280 assorted magnetic symbols (10 mm)
70 each in red, blue, green and yellow,
 - 40 label holders (10 x 60 mm)
 - 6 sheets of labels: 1 sheet each in yellow, pink, red, green,
blue and white (45 labels per sheet)

Ref.no. 7-435200



Planning set 3:

- For up to 75 people / events / projects
- Contents:
 - 1 wallet of TZ 140 / set of 4 board markers, assorted
 - 1 OHP pen edding 152 M (black)
 - 24 magnetic strips (10 x 300 mm)
6 each in red, blue, green and yellow
 - 280 assorted magnetic symbols (10 mm)
70 each in red, blue, green and yellow
 - 10 label holders (20 x 60 mm)
 - 3 sheets of labels:
 - 1 sheet each in yellow, white, green (18 labels per sheet)
 - 75 label holders (10 x 60 mm)
 - 12 sheets of labels: 2 sheets each in yellow, pink, red, green,
blue and white (45 labels per sheet)

Ref.no. 7-435300

PLANNING



Planners 2013

- Size: H 60 x W 90 cm
(Traditional vertical cardboard year planner H 90 x W 60 cm)
- Other languages available on request
- Season article, available till end of stock

Cardboard planners

- Cardboard: 400 g/m²

Laminated planners

- Laminated version enhances durability and can be dry wiped after using board markers or wiped with a damp cloth after using non permanent OHP pens
- Lamination foil includes polypropylene, ensuring a perfect transparent and strong planner surface

Rolled up planners

- Paper quality: 170 g/m²
- Laminated planner surface
- Packed individually
- Cash & carry packaging
- Comes complete with accessories

Traditional horizontal cardboard year planner

- Year planner with days across the top (first two letters only) and months down the side
- Weekends are marked in a different colour
- Space for notes at the bottom of the planner
- Week numbers are integrated in the design
- Day grid size approx.: H 42 x W 22 mm

1



Country	Ref.no. Cardboard	Ref.no. Laminated	Ref.no. Rolled up
Germany and Austria	7-420021-13	7-420121-13	7-420221-13
Benelux	7-420022-13	7-420122-13	7-420222-13
Switzerland	7-420025-13	7-420125-13	7-420225-13
France	-	7-420126-13	7-420226-13

Traditional vertical cardboard year planner

- Year planner with months across the top and days down the side
- Weekends are marked in a different colour
- Space for notes at the bottom of the planner
- Week numbers are integrated in the design
- Day grid size approx.: H 21 x W 42 mm

2



Country	Ref.no. Cardboard	Ref.no. Laminated	Ref.no. Rolled up
Germany and Austria	7-421021-13	7-421121-13	7-421221-13
Benelux	7-421022-13	7-421122-13	7-421222-13
Switzerland	7-421025-13	7-421125-13	7-421225-13
France	-	7-421126-13	7-421226-13



3

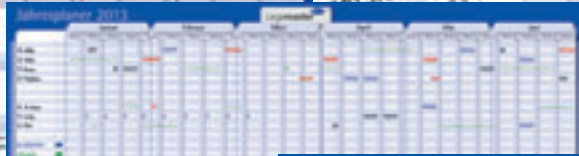

4



5

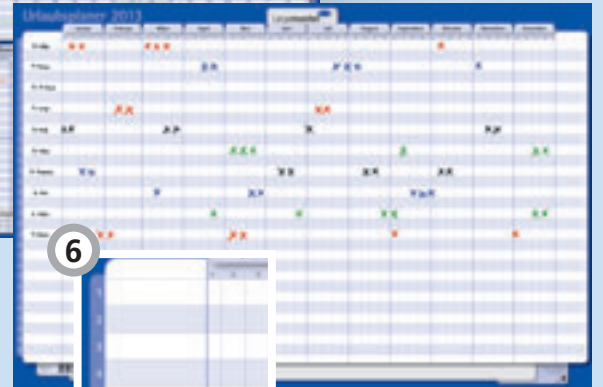

6

3 Personal vertical cardboard year planner

- Year planner with months across the top and days down the side (first letter only)
- Vertical year planner in a landscape format
- Three extra columns for each month; helps indicating priorities
- Weekends are marked in a different colour
- Space for notes at the bottom of the planner
- Week numbers are integrated in the design
- Day grid size approx.: H 14 x W 46 mm

Country	Ref.no. Cardboard	Ref.no. Laminated	Ref.no. Rolled up
Germany and Austria	7-422021-13	7-422121-13	7-422221-13
Benelux	7-422022-13	7-422122-13	7-422222-13
Switzerland	7-422025-13	7-422125-13	7-422225-13
France	-	7-422126-13	7-422226-13

5 Cardboard holiday planner April-March

- Ideal for planning holidays; half year blocks can be broken down as April-September and October-March
- Includes school term dates
- Day grid size approx.: H 7 x W 4 mm

Country	Ref.no. Cardboard	Ref.no. Laminated	Ref.no. Rolled up
Germany, Austria and Switzerland	7-424021-13	7-424121-13	7-424221-13
Benelux	7-424022-13	7-424122-13	7-424222-13
France	-	-	7-424226-13

4 Cardboard project planner

- Year planner with months across the top and projects down the side
- Two 6 month blocks, one above the other
- For up to 30 projects, staff members, events or tasks
- Weekends are marked in a different colour
- Space for notes at the bottom of the planner
- Week numbers are integrated in the design
- Day grid size approx.: H 7 x W 4.2 mm

Country	Ref.no. Cardboard	Ref.no. Laminated	Ref.no. Rolled up
Germany and Austria	7-423021-13	7-423121-13	7-423221-13
Benelux	7-423022-13	7-423122-13	7-423222-13
Switzerland	7-423025-13	7-423125-13	7-423225-13
France	-	7-423126-13	7-423226-13

6 Cardboard holiday planner January-December

- Year planner with months across the top and space for staff members down the side
- For up to 30 staff members
- Space for notes at the bottom of the planner
- Additional space for notes at the right side of the planner
- Week numbers are integrated in the design
- Week grid size approx.: H 16 x W 15 mm

Country	Ref.no. Cardboard	Ref.no. Laminated	Ref.no. Rolled up
Austria	7-425021-13	7-425121-13	7-425221-13
Benelux	7-425022-13	7-425122-13	7-425222-13
Switzerland	7-425025-13	7-425125-13	7-425225-13
France	7-425026-13	7-425126-13	7-425226-13

PLANNING

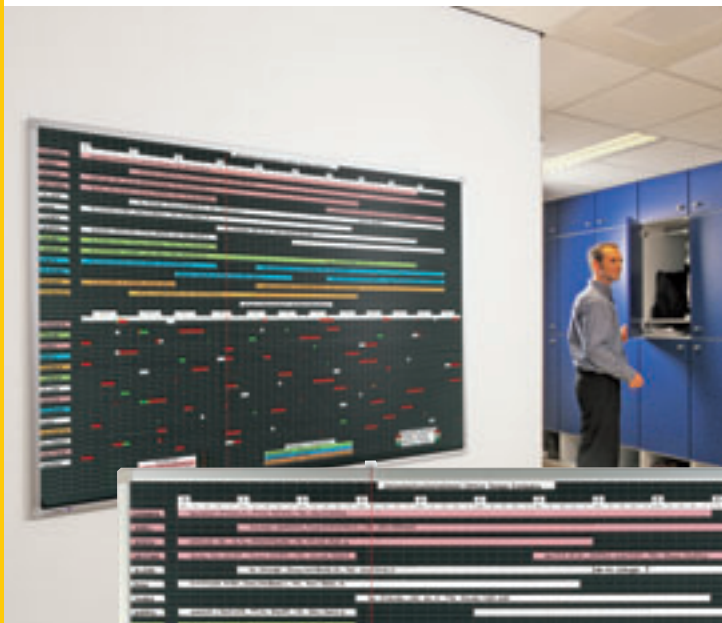

PROFESSIONAL channel planner

- High quality plastic channels
- Patented self-wedge design with groove to hold planning strips and plastic signals firmly
- The number of scaled planning areas tells you how many periods and headings you can plan
- 2 planning tasks on one board possible
- Many accessory combinations available
- Comes complete with fixing kit

43 channels, 42 scaled planning areas (20 mm)

Height x Width	Ref.no.
60 x 90 cm	7-460043

68 channels, 57 scaled planning areas (20 mm)

Height x Width	Ref.no.
90 x 120 cm	7-460054

93 channels, 82 scaled planning areas (20 mm)

Height x Width	Ref.no.
120 x 170 cm	7-460074



Recommended accessories:

- Basic set
Ref.no. 7-465200 (see below)
- Mobile pedestal stand on castors
Ref.no. 7-170500



Basic set

- Specially designed for board sizes from 120 to 170 cm wide
- Comes complete with container for loose signals
- Recommended for Ref.no. 7-460054 and Ref.no. 7-460074
- Contents:
 - 100 each of 4, 8 and 20 mm wide signals (assorted colours)
 - 200 planning strips assorted (10 colours)
 - 100 planning strips (white)
 - one sheet of Mon-Sun, weeks 1-53 and months January-December
 - Date line with plastic runners
 - Calendar week strips for 5 and 7 day weeks

Ref.no. 7-465200



Signals and strips

Plastic signals

- Plastic signals, assorted in 5 colours: red, blue, green, yellow, white
- Set of 100 signals
- Height of one signal: 10 mm

Width	Ref.no.
4 mm	7-466199
8 mm	7-466299
20 mm	7-466399

Planning strips

- Planning strips in a single colour or assorted colours, available colours: red, blue, green, yellow, white
- Card strips 30 cm long, visible height 13 mm each edge
- 100 strips

Colour	Ref.no.	
Single colour	7-4670xx	add colour code
Five assorted colours	7-467100	

02	03	04	05	19
red	blue	green	yellow	white

Calendar strip set 1

- Weekday strips: Mon to Sun
Sheet with 6 card strips · 2 x 6 = 12 weeks on the sheet · day units each 20 mm wide
- Calendar strips: weeks 1-53 and months January to December
Sheet with 6 card strips · weeks 1-53 and names of the months January to December · week units each 20 mm wide · month units each 60 mm wide
- In two languages: English and German

Ref.no. 7-468500

Calendar strip set 2

- Calendar strips: 5 day week and months January to December
Sheet with 6 card strips · 5 day week strips and months January to December · week units each 20 mm wide (days 4 mm) · month units each 50 mm wide · set of one sheet each for current and following year
- Calendar strips: 7 day week
Sheet with 6 card strips · 7 day week strips with week units each 28 mm wide (days 4 mm) · set of one sheet each for current and following year
- In two languages: English and German

Ref.no. 7-468600

PLANNING



Slide index system

Whether you wish to show comprehensive staffing information or detailed room bookings (e.g. for conference rooms), the slide index system will bring order to the matter – and that's guaranteed! The system's modules are available in 3 different lengths and two widths and can be used in combination with each other, all come complete with their own device for attachment. One module can hold up to 60 cards providing a clear, colourful and structured overview.

If something changes, there's no problem: simply remove the card and holder from the rail and watch all the remaining cards simply slide down into place and fill the gap you have just created; new cards can also be added in the same way.

- Works on the basis of the "follow my leader principle" – order is maintained even if individual card holders are taken out
- No problems with combining modules
- Magnetic strips on reverse side to prevent modules from slipping
- Support rails made of anodised aluminium
- Comes complete with rail for mounting, fixing kit and card holders

How to use the system:

STEP 1

Choose the size T-card

T-cards come in 2 sizes, so choosing the size you want to use is your first decision.

STEP 2

Determine the number of slots

The planning system boards are assembled from vertical panels with slots for the T-Cards. The width of the planner panel will correspond with the width of the T-Cards you have chosen. You can choose from 3 panel heights and from 2 panel widths.

STEP 3

Determine the number of panels

Choose the number of panels based on how many days or tasks etc. your system requires.



Planning modules with support rails



■ Available in 2 widths and 3 lengths

70 mm wide:

T cards	Length	Ref.no.
For 32 T cards	640 mm	7-472100
For 45 T cards	830 mm	7-472200
For 60 T cards	1050 mm	7-472300

101 mm wide:

T cards	Length	Ref.no.
For 32 T cards	640 mm	7-473100
For 45 T cards	830 mm	7-473200
For 60 T cards	1050 mm	7-473300

T-cards



- Strong card
- 240 gsm card
- Front ruled, reverse side blank
- Pack of 100
- Available in red, blue, green, yellow, orange, pink and white
- Just add the right colour code to Ref.no.

For Planning modules	A	B	C	Ref.no.
Medium: 70 mm wide	61 mm	48 mm	83 mm	7-4752xx
Wide: 101 mm wide	91 mm	79 mm	105 mm	7-4753xx

02	03	04	05	06	09	19
red	blue	green	yellow	orange	pink	white

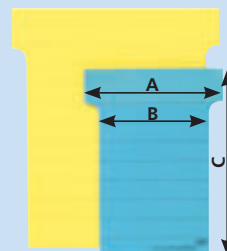

INFORMATION

Information boards and showcases are just two examples of information products which make it easy to display schedules, pictures, memos and other important information in your office, school or shop. Instant and effective communication will be generated through the many information products Legamaster offers.

Wall mounted or free standing? Portrait or landscape? Whiteboard, letterboard or pinboard? For every question Legamaster has an answer i.e. information will be kept safe when displayed in a lockable showcase, and for hanging pictures, EXPORAIL is a practical and flexible solution.



PROFESSIONAL showcases



- For interior use
- Magnetic surface, can be written on with dry wipe board markers
- Top quality information showcase
- Aluminium frame
- Two acrylic glass sliding doors, lockable
- Depth (interior): approx. 20 mm
- Enamel surface (fired at 800°C)
- Acid and scratch resistant
- Comes complete with mounting instructions, mounting material and two door keys
- Write on / dry wipe surface is guaranteed for 25 years when used in combination with Legamaster accessories

Height x Width	External dimensions H x W x D	Weight	Ref.no.
90 x 120 cm	94 x 124 x 7.5 cm	27 kg	7-630054
90 x 180 cm	94 x 184 x 7.5 cm	37 kg	7-630056

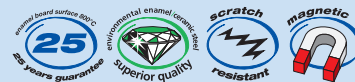

PREMIUM outdoor showcases



- For outdoor use, designed to withstand various light weather conditions
- Magnetic surface; can be written on with dry wipe board markers
- Anodised aluminium frame and aluminium angles for a maximum resistance
- Special safety perspex swing door provided with an aluminium frame and an incorporated lock (on request available with special safety glass)
- Product and product parts: 5-year guarantee
- Various showcase sizes; up to 18 DIN A4
- Easy installation and the possibility to mount the showcase with a to the right or to the left opening swing door
- Frame thickness 35 mm
- Comes complete with mounting instructions, mounting material and two door keys

Height x Width	Qty / DIN A4	Ref.no.
692 x 518 mm	4	7-630636
518 x 692 mm	4	7-630646
692 x 730 mm	6	7-630644
692 x 940 mm	9	7-630642
989 x 730 mm	9	7-630647
730 x 989 mm	9	7-630660
989 x 940 mm	12	7-630645
989 x 1358 mm	18	7-630662



INFORMATION

PREMIUM indoor showcases

- For indoor use
- Better quality information showcase
- Magnetic surface; can be written on with dry wipe board markers
- Anodised aluminium frame with aluminium angles for a maximum resistance
- Perspex glass swing or sliding door provided with an aluminium frame and an incorporated lock; lockable with keys
- Product and product parts: 5-year guarantee



Swing door:

- Various showcase sizes; up to 18 DIN A4
- Easy installation and the possibility to mount the showcase with a to the right or to the left opening door
- Frame thickness 32 mm
- Comes complete with mounting instructions, mounting material and two door keys

Height x Width	Qty / DIN A4	Ref.no.
353 x 476 mm	2	7-630734
650 x 476 mm	4	7-630736
476 x 650 mm	4	7-630746
650 x 686 mm	6	7-630744
650 x 896 mm	8	7-630742
947 x 686 mm	9	7-630747
686 x 947 mm	9	7-630760
947 x 896 mm	12	7-630759
947 x 1316 mm	18	7-630748

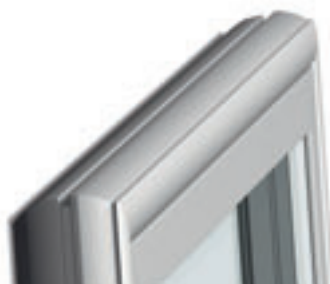

Sliding door:

- Various showcase sizes; up to 27 DIN A4
- Suitable for installation in, for example, small corridors
- Frame thickness 50 mm
- Comes complete with mounting instructions, mounting material, two grey handgrips (aluminium look) and two door keys

Height x Width	Qty / DIN A4	Ref.no.
653 x 899 mm	8	7-630942
950 x 690 mm	9	7-630947
690 x 950 mm	9	7-630960
653 x 1319 mm	12	7-630945
950 x 1120 mm	15	7-630961
950 x 1523 mm	21	7-630963
950 x 1949 mm	27	7-630964



ECONOMY showcases



- For indoor use
- Magnetic surface; can be written on with dry wipe board markers
- Anodised aluminium frame with aluminium angles for a maximum resistance
- Perspex glass swing door provided with an aluminium frame and an incorporated lock; lockable with keys
- Product and product parts: 5-year guarantee
- Various showcase sizes; up to 9 DIN A4
- Frame thickness only 20 mm (extra thin)
- Comes complete with mounting instructions, mounting material and two door keys

Height x Width	Qty / DIN A4	Ref.no.
338 x 251 mm	1	7-631732
338 x 461 mm	2	7-631734
635 x 461 mm	4	7-631736
461 x 635 mm	4	7-631746
635 x 671 mm	6	7-631744
635 x 881 mm	8	7-631742
932 x 671 mm	9	7-631747
671 x 932 mm	9	7-631760



ECONOMY key holder showcases



- For indoor use
- Special key holder showcase
- Holds 45 or 90 keys
- Lockable, acrylic glass door
- Aluminium frame
- Swing door
- Comes complete with mounting instructions, mounting material and two door keys

Height x Width	Keys	Ref.no.
50 x 35 cm	45	7-632534
50 x 70 cm	90	7-632536



The solution for storing your keys.

INFORMATION

PREMIUM poster frames



- Top quality poster frame
- Clear presentation of messages and / or posters
- Stable frame construction
- Wall mount
- Clip-opening mechanism; stainless steel springs
- Transparent sheet with UV protection, protects the poster
- White front material and black polystyrene backing material
- Elegant design; anodised silver frame with matt dark grey corner caps
- Frame width: 25 mm or 35 mm
- Includes mounting material

Height x Width	Frame	DIN	Ref.no.
341 x 254 mm	25 mm	A4	7-632631
464 x 341 mm	25 mm	A3	7-632633
644 x 470 mm	35 mm	A2	7-632735
891 x 644 mm	35 mm	A1	7-632744

PREMIUM poster frames on a stand

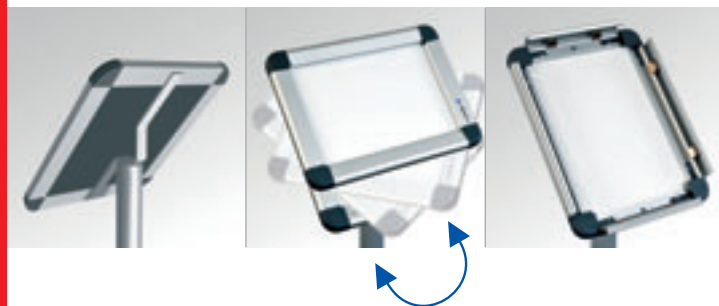

- For A4 and A3 poster formats
- Snap-open poster-change system
- Angled frame can be shown portrait or landscape; change of position in a second
- Anti-glare sheet for poster protection
- Fixed height (maximum height: 114 cm)
- Sturdy metal base
- Base weight: 6 kg, width 30 cm
- Easy to assemble

Height x Width	DIN	Ref.no.
341 x 254 mm	A4	7-635531
464 x 341 mm	A3	7-635533

Magnetic document holders

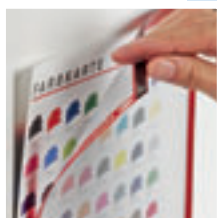
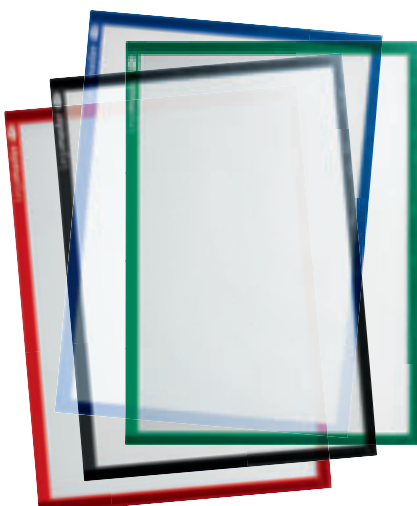

- Simple and fast switching of documents
- Magnetic document holders for attaching to a (white)board
- Systematically present your messages on a whiteboard or any other steel surface
- Magnetic backside strips on three sides of the holder
- Can be used horizontally or vertically
- UV protection
- Transparent foil surface
- Packed per 5 pieces
- Coloured border: available in black, red, blue and green
- Just add the right colour code to Ref.no.

DIN	Ref.no.
A4	7-6356xx

01	02	03	04
black	red	blue	green

PROFESSIONAL In & out board



- Attendance board
- Name cards slide easily from side to side
- Name cards can easily be changed
- Aluminium frame with light grey corner caps
- Comes complete with fixing kit and blank name plates
- Comes complete with "In and out" plate in 4 languages: English, German, French and Dutch

Height x Width	People	Ref.no.
31 x 26 cm	10	7-622100
54 x 26 cm	20	7-622200
77 x 26 cm	30	7-622300

You name it, we engrave it

- Name plates in white plastic with black engraved requested lettering
- Letter height 8 mm, max. 20 letters
- White name plates that are easy to write on using either a permanent marker or any label printer

Ref.no. 7-622500

PROFESSIONAL In & out board

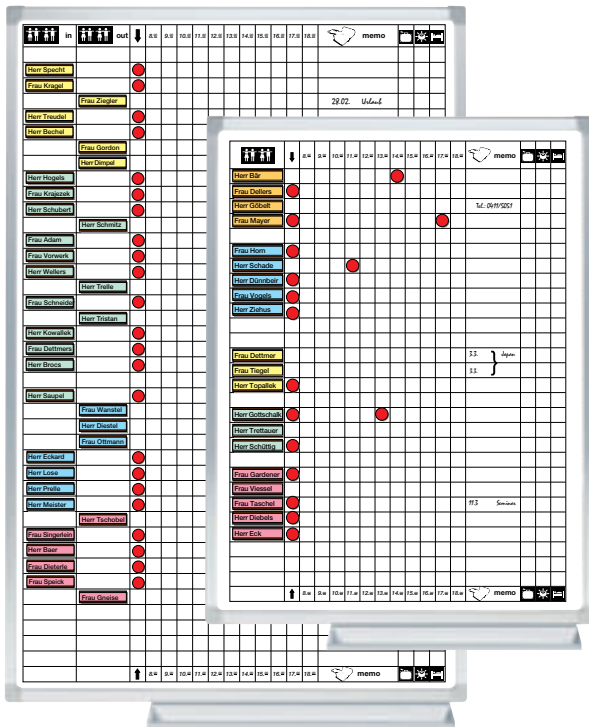

- High quality in & out board with enamel writing surface
- Light-weight honeycomb board structure
- Attendance board for up to 25/40 people
- Shows return times and other details at a glance
- Ideal for reception areas
- Comes complete with fixing kit, one board marker and marker tray
- Enamel surface (fired at 800°C)
- Acid and scratch resistant
- Write on/dry wipe surface is guaranteed for 25 years when used in combination with Legamaster accessories

Height x Width	For up to	Box sizes approx. H x W	Ref.no.
60 x 45 cm	25 people	18 x 18 mm	7-620100
90 x 60 cm	40 people	20 x 20 mm	7-620200

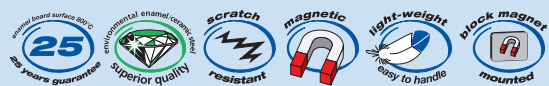

Recommended accessory set:
Accessory kit for in & out board
Ref.no. 7-620500

Accessory kit for in & out board

- Contents:
 - Set of 4 board markers (black, red, blue, green)
 - 40 magnets (ø 10 mm) in red
 - 40 label holders (15 x 60 mm)
 - 5 sheets of labels: 1 sheet each in white, yellow, pink, green and blue (24 labels per sheet)

Ref.no. 7-620500



INFORMATION



Legaline PROFESSIONAL floor system

The Legamaster floor display system opens up all manner of possible uses in places such as hotels and banks, acting as a practical room partition in offices or placed directly in work spaces or public areas.

The individual parts of the presentation screen system – the double sided boards, the stands, bases and coupling set – can be linked together quickly, in many different combinations and are continuously variable height adjustable.

Try different surfaces to add that extra slant; to create a room designed for communication.

Whiteboards for Legaline PROFESSIONAL

- High quality double sided whiteboards
- Scratch resistant, enamel steel board surface
- Particularly well suited for long term use
- Magnetic and suitable for writing on with dry wipe board markers
- Can be mounted vertically or horizontally
- Powder coated white (RAL 9016) aluminium frame
- Write on / dry wipe surface is guaranteed for 25 years when used in combination with Legamaster accessories
- Please order a coupling kit separately

Height x Width	Ref.no.
90 x 120 cm	7-640254
90 x 150 cm	7-640255
120 x 150 cm	7-640273



Pinboards for Legaline PROFESSIONAL

- High quality double sided pinboards
- Durable felt covering on both sides
- Particularly well suited for long term use
- Can be mounted vertically or horizontally
- Powder coated white (RAL 9016) aluminium frame
- Please order a coupling kit separately

Height x Width	Ref.no. Blue felt	Ref.no. Grey felt
90 x 120 cm	7-641554	7-641654
90 x 150 cm	7-641555	7-641655
120 x 150 cm	7-641573	7-641673



Recommended accessory:
Push-pins in assorted colours
Ref.no. 7-1451xx



Combine the different elements of the floor system to create a professional "communication wall" which suits your needs best!



Legaline PROFESSIONAL accessories

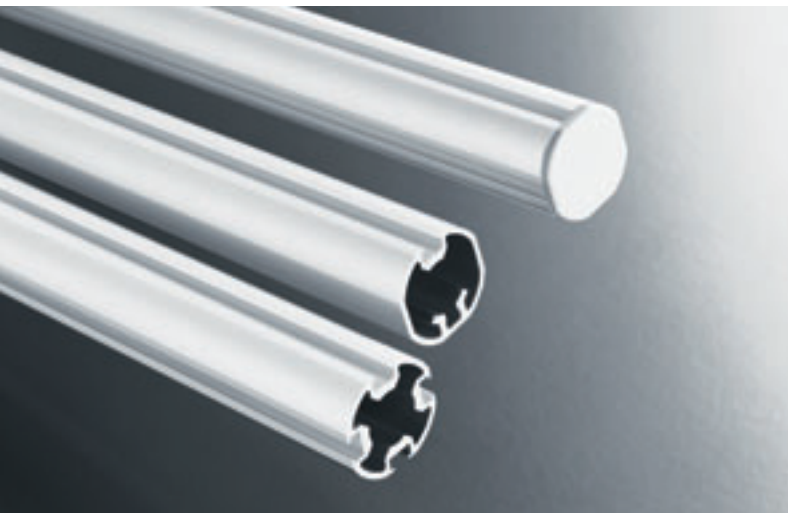

1- and 4-channel stands

- Suitable for all double-sided Legaline PROFESSIONAL boards
- Powder coated white (RAL 9016) aluminium

Single-channel stand (end pole)

Height	Ref.no.
180 cm	7-642200
200 cm	7-642300

4-channel stand (connecting poles)

Height	Ref.no.
180 cm	7-642700
200 cm	7-642800



Bases for channel stands

- Plastic base cap diam. 40 mm height adjustable for 3 cm
 - Suitable for connecting poles only
- Ref.no. 7-643300
- Iron bar shaped base
length 50 cm, weight approx. 0.7 kg
 - Particularly suitable as an endpole, for example positioned next to a wall. To be combined with a circular iron base for optimal support
- Ref.no. 7-643200

- Circular iron base
diam. 35 cm, weight approx. 3.6 kg
- Particularly suitable for end poles,
for optimal support

Ref.no. 7-643100

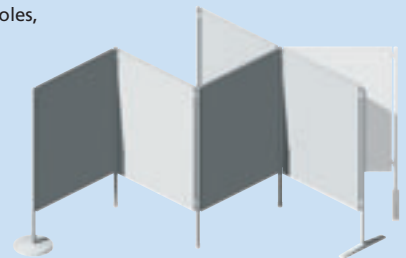

Coupling kit

- Connects boards together at any angle
- Set of 4 couplings for one board
- Coupling kits are not included in the delivery of the floor display system. Please order kits separately

Ref.no. 7-645100



*Many possibilities
to connect the
several boards!*

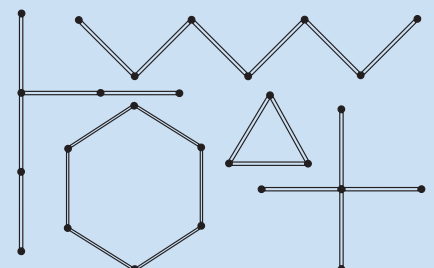

INFORMATION



PROFESSIONAL maps

- Top quality map
- Political maps, road maps or postal district maps from leading map publishers
- Magnetic map surface
- Suitable for writing on with dry wipe board markers
- Laminated map surface is UV resistant
- Laminated foil guarantees dry wipeability
- Light weight honeycomb board structure
- Aluminium board frame with light grey plastic corner caps
- Comes complete with marker tray and fixing kit
- Other maps and languages available on request
- R = includes place-name index



World

■ Kümmery & Frey political map
Ref.no. 7-610000



Europe

■ Maps International
Ref.no. 7-610100

Map	Scale	Size H x W	Ref.no.
World	1: 30 000 000	98 x 142 cm	7-610000
Europe	1: 4 300 000	100 x 137 cm	7-610100
Benelux (R)	1: 500 000	120 x 95 cm	7-610200
Germany	1: 700 000	127 x 97 cm	7-611100
Netherlands (R)	1: 250 000	130 x 101 cm	7-612100
Netherlands (R)	1: 250 000	129 x 101 cm	7-612200
Belgium (R)	1: 250 000	101 x 121 cm	7-613100



Benelux (R)

■ Falkplan road map
Ref.no. 7-610200



Germany

■ Bacher Verlag road map
Ref.no. 7-611100



Netherlands (R)

■ Falkplan road map
Ref.no. 7-612100



Netherlands (R)

■ Buijten & Schipperheijn postal district map
Ref.no. 7-612200



Belgium (R)

■ Falkplan road map
■ Includes Belgium and Luxembourg
Ref.no. 7-613100

New editions of maps may contain alterations. We therefore reserve the right to alter the maps.



INFORMATION

PREMIUM information boards

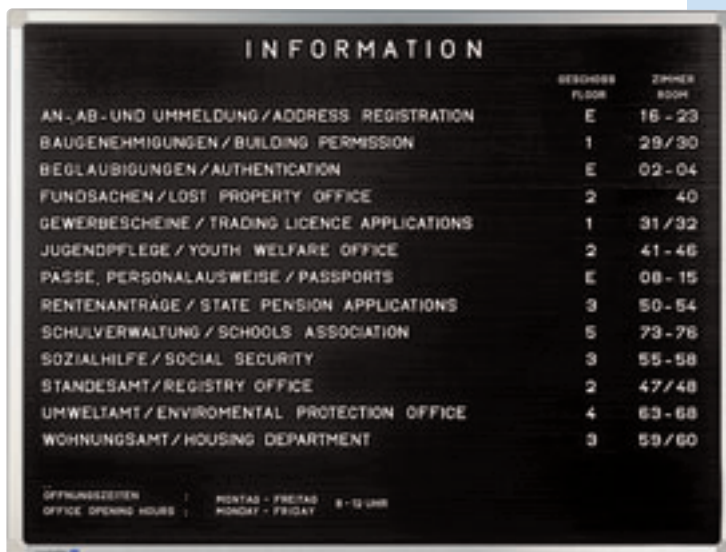

- Traditional information board
- Black, ridged rubber board surface
- Display messages (welcome!), announcements, route directions or general company information
- Attach and change letters easily
- Aluminium frame with light grey plastic corner caps
- Letters, numbers and characters available in 3 different heights
- Comes complete with fixing kit

Height x Width Ref.no.

30 x 40 cm	7-600033
40 x 30 cm	7-600034
40 x 60 cm	7-600035
60 x 40 cm	7-600041
60 x 80 cm	7-600043
80 x 60 cm	7-600052

Maximum number of lines

Board height cm	30	40	60	80
Letter height	Number of lines			
12 mm	15	20	30	40
20 mm	12	16	24	32
30 mm	9	12	18	24

Maximum number of letters horizontal

Board width cm	30	40	60	80
Letter height	Number of letters horizontal			
12 mm	25	33	50	67
20 mm	15	21	31	41
30 mm	11	14	22	29



Doorplates

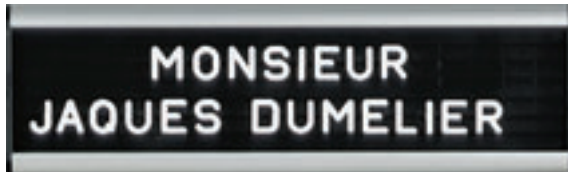

- Aluminium holder
 - Acrylic panel
 - Plastic end caps
 - Suitable for one line of 20 mm letters or two lines of 12 mm letters
 - H 6 x W 25 cm
- Ref.no. 7-601100

Letters and numbers



Letter height	A	B	C	D	E	F	G	H	I	J	K	L	M	N	O	P	Q	R	S	T	U	V	W	X	Y	Z
H 12 mm	24	8	8	16	32	8	8	8	16	8	16	16	16	24	16	8	8	16	16	16	16	16	8	8	8	8
H 20 mm	24	8	8	16	32	8	8	8	16	8	16	16	8	24	16	8	8	16	16	16	16	16	8	8	8	8
H 30 mm	16	8	8	8	16	8	8	8	8	8	8	8	8	16	8	8	8	8	8	8	8	8	8	8	8	8

Letter height	1	2	3	4	5	6	7	8	9	0	.	,	!	?	()	/	-	-	"	€					
H 12 mm	16	8	8	8	16	8	8	8	8	16	24	24	8	8	8	8	8	8	8	8	8	8	8	8	8	8
H 20 mm	16	8	8	8	16	8	8	8	8	8	24	24	8	8	8	8	8	8	8	8	8	8	8	8	8	8
H 30 mm	8	8	8	8	8	8	8	8	8	8	16	8	8	8	8	8	8	-	-	-	8	8	8	8	8	



In & out doorplate

- The international doorplate
 - By covering the green or red side of the doorplate the user can indicate whether the room is available or not
 - Rounded aluminium holder with black slide system
 - Aluminium frame
 - Polystyrene panel
 - Plastic end caps
 - H 6 x W 25 cm
- Ref.no. 7-601200

- White plastic letters
- Box size: L 36 x W 25 x H 5 cm

Boxes full of character:

- Indispensable for use with PREMIUM information boards
- Each character supplied in a quantity designed to reflect its frequency of use
- Box with separate compartments for each letter
- For contents, see below

Letter height	Characters	Ref.no.
H 12 mm	576	7-605100
H 20 mm	560	7-605200
H 30 mm	384	7-605300

Supplementary sets:

- Complete set of letters, numbers and characters in all available sizes
- This box contains half of the quantity mentioned below
- It is only possible to order the complete box of supplements

Letter height	Characters	Ref.no.
H 12 mm	288	7-606100
H 20 mm	280	7-606200
H 30 mm	192	7-606300

INFORMATION



EXPORAIL suspension system

EXPORAIL is the practical suspension system for hanging and moving about all kinds of pictures and posters in all standard formats.

Blending in nicely with any room, you can rearrange your suspension system over and over at the flick of a wrist. Whatever you want to focus on, the EXPORAIL suspension system always plays the perfect backdrop, with paper holders for adjusting your drawings and picture hooks to give your artwork a firm hold.

- Attractive hanging system for various wall decorations such as paintings, pictures, posters, drawings and signs
- Wall decorations can be arranged and re-positioned in a flexible way
- No need to drill holes for every separate wall decoration
- Quick and easy assembly
- Elegant and hardly visible system



Track

- Attractive way to hang pictures, posters, drawings and signs
- Powder coated white (RAL 9016) aluminium

Lenght	Ref.no.
120 cm	7-650110
180 cm	7-650120
240 cm	7-650130



Paper grippers

- Paper grippers firmly hold (paper) drawings
 - Grippers can be attached to any point on the rail
 - The size of the picture will determine how many grippers you need
 - White plastic
 - Pack of 6 paper grippers
- Ref.no. 7-655600



Picture hooks

- Wall decorations can be adjusted in height in a flexible way
- If you would like to hang several pictures above one another, just add extra hooks to the nylon cord
- Set comprises two aluminium hooks and strong nylon cord for each picture
- 2 mm strong cord will take loads up to 50 kg
- Use the Allan key provided to adjust the cord to whatever height you choose

	Ref.no.
2 hooks + 1 m nylon cord	7-655100
5 m nylon cord	7-655200
6 hooks	7-655500

- Simplified EXPORAIL mounting system

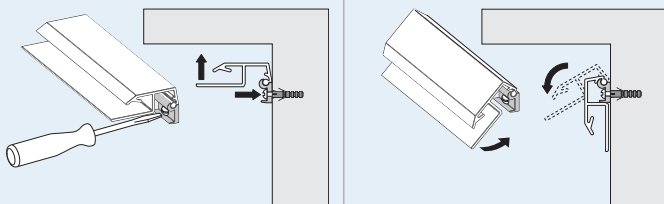

Accessories



Retractable marker TZ 14	Ref.no. 7-1125xx	page 133
Board marker TZ 1	Ref.no. 7-1100xx	page 133
Board marker TZ 100	Ref.no. 7-1105xx	page 134
Board marker PLUS TZ 10	Ref.no. 7-1110xx	page 134
Board marker TZ 140	Ref.no. 7-1140xx	page 135
Board marker TZ 150	Ref.no. 7-1150xx	page 135
Board marker JUMBO TZ 180	Ref.no. 7-1180xx	page 135

Refill ink for board markers	Ref.no. 7-1195xx	page 136
Refill ink for board markers	Ref.no. 7-1199xx	page 136
Refill ink for TZ 14	Ref.no. 7-1129xx	page 136

Small whiteboard eraser	Ref.no. 7-120100	page 137
Magnetic whiteboard eraser	Ref.no. 7-120300	page 137
Whiteboard eraser TZ 4	Ref.no. 7-120500	page 137

Whiteboard cleaner TZ 6	Ref.no. 7-121000	page 138
Whiteboard cleaner TZ 7	Ref.no. 7-121200	page 138
Whiteboard cleaner TZ 8	Ref.no. 7-121300	page 138
Whiteboard cleaner TZ 66	Ref.no. 7-121400	page 138
MagicWipe	Ref.no. 7-121500	page 139

Marker holder	Ref.no. 7-122000	page 139
Board assistant	Ref.no. 7-122500	page 139

Tacking magnets	Ref.no. 7-1810xx - Ref.no. 7-1814xx	page 146
-----------------	--	----------

Push-pins in assorted colours	Ref.no. 7-1451xx	page 145
Push-pins, assorted	Ref.no. 7-145299	page 145

Accessory kit for in & out board	Ref.no. 7-620500	page 123
----------------------------------	------------------	----------

ACCESSORIES

There is a wide range of Legamaster accessories available to help maintain your products in good condition. From cleaners to erasers, markers to magnetic accessories, Legamaster offers the complete solution, all carefully chosen to ensure the highest of standards.

Our wide selection of accessories and high quality products mean that you can display notes and ideas securely without any trouble, and removing them is just as easy!



TZ 14 Retractable marker



- Ready to use immediately, operate with one hand
- Never lose a cap again!
- Tip can be revealed by using the push button at the end of the marker, retract tip by pressing the push button in the clip or by lifting up the clip slightly
- When you retract the tip after use, it is protected against drying out by a special closing system in the barrel
- For use on whiteboards and flipcharts
- Easily removed from all whiteboard surfaces
- Plastic barrel with push button and mouth piece in writing colour
- Quick and easy refill in colours 1 to 4
- For refilling the markers, use the 25 ml bottle Ref.no. 7-1129xx (capillary system)
- Alcohol-based, low-odour ink
- Length: 14.5 cm, diam. 16.3 mm

Tip:

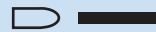

Stroke width:
approx. 1.5 – 3.0 mm

TZ 14 Pack of 10, single colour
Please state colour code with order
Ref.no. 7-1125xx

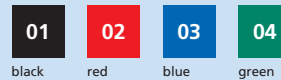

TZ 1 Board marker



- For use on whiteboards and flipcharts
- Easily removed from all whiteboard surfaces
- Aluminium barrel
- Quick and easy refill in colours 1 to 4
- For refilling the markers, use the 25 ml bottle Ref.no. 7-1195xx (capillary system) or the 100 ml bottle Ref.no. 7-1199xx (dropper system)
- Alcohol-based, low-odour ink
- Length: 13.8 cm, diam. 14 mm
- Cap Off ink protects against rapid drying out

Tip:

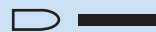

Stroke width:
approx. 1.5 – 3.0 mm

TZ 1 Pack of 10, single colour or assorted
Please state colour code with order
Ref.no. 7-1100xx

TZ 1 Wallet of 4, assorted: black, red, blue and green
Ref.no. 7-110094

TZ 1 Wallet of 6, assorted:
black, red, blue, green, orange and purple
Ref.no. 7-110096

10 replacement nibs for TZ 1
Ref.no. 7-110300



ACCESSORIES

TZ 100 Board marker

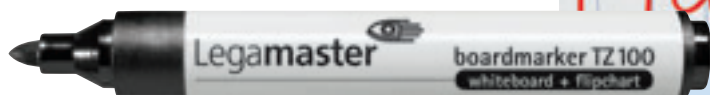

- For use on whiteboards and flipcharts
- Easily removed from all whiteboard surfaces
- Plastic barrel
- Quick and easy refill in colours 1 to 4
- For refilling the markers, use the 25 ml bottle Ref.no. 7-1195 xx (capillary system)
- Alcohol-based, low-odour ink
- Length: 13.8 cm, diam. 14 mm

Tip:

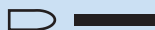

Stroke width:
approx. 1.5 – 3.0 mm

TZ 100 Pack of 10, single colour
Please state colour code with order
Ref.no. 7-1105xx

TZ 100 Wallet of 4, assorted: black, red, blue and green
Ref.no. 7-110594



PLUS TZ 10 Board marker and refill cartridge TZ 11



- For use on whiteboards and flipcharts
- Free-flow ink system to make your marker last longer
- Pump valve in the tip for smooth flow
- Easily removed from all whiteboard surfaces
- Environmentally friendly
- Large ink reservoir with facility to see exactly how much ink is left
- Quick and easy refill with TZ 11 ink cartridges
- Alcohol-based, low-odour ink
- Length: 13.8 cm, diam. 14 mm

Tip:

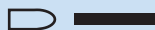

Stroke width:
approx. 1.5 – 3.0 mm

TZ 10 Pack of 10, single colour
Please state colour code with order
Ref.no. 7-1110xx

TZ 10 Wallet of 4, assorted: black, red, blue and green
Ref.no. 7-111094

TZ 11 Pack of 5 refill cartridges in a single colour
Please state colour code with order
Ref.no. 7-1119xx

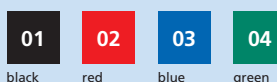

TZ 140 Board marker



- For very fine lettering, ideal for planners
- Can be dry-wiped off all whiteboard surfaces
- Quick drying
- Quick and easy refill
- For refilling the markers, use the 25 ml bottle Ref.no. 7-1195xx (capillary system) or the 100 ml bottle Ref.no. 7-1199xx (dropper system)
- Alcohol-based, low odour ink
- Length: 14.5 cm, diam. 12 mm

Tip:

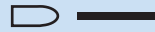

Stroke width:
approx. 1.0 mm

Ideal marker for planning boards.



TZ 140 Pack of 10, single colour
Please state colour code with order
Ref.no. 7-1140xx

TZ 140 Wallet of 4, assorted: black, red, blue and green
Ref.no. 7-114094



TZ 150 and JUMBO TZ 180 Board marker



- Bold strokes for extra effect
- Particularly well suited for headings and underlining
- For use on whiteboards and flipcharts
- Easily removed from all whiteboard surfaces
- Quick and easy refill
- For refilling the markers, use the 100 ml bottle Ref.no. 7-1199xx (dropper system)
- Alcohol-based, low-odour ink
- TZ 150:
Length: 12 cm, diam. 21 mm
- TZ 180:
Length: 15.8 cm, diam. 26 mm

Tip:



Stroke width TZ 150:
approx. 2.0 – 7.0 mm

Tip:



Stroke width TZ 180:
approx. 3.0 – 12.0 mm

TZ 150 Pack of 10, single colour
Please state colour code with order
Ref.no. 7-1150xx

TZ 150 Wallet of 4, assorted: black, red, blue and green
Ref.no. 7-115094

TZ 180 Pack of 10, single colour
Please state colour code with order
Ref.no. 7-1180xx

TZ 180 Wallet of 4, assorted: black, red, blue and green
Ref.no. 7-118094



ACCESSORIES

MINI TZ 111 Board marker



- Small and fine for finer lines
- Bullet tip
- For use on whiteboards and planboards
- Easily removed from all whiteboard surfaces
- Plastic barrel
- Alcohol-based, low odour ink
- Length: 10.3 cm, diam. 11 mm

Tip:

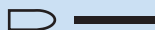

Stroke width:
approx. 1.0 mm

TZ 111 Pack of 10, single colour
Please state colour code with order
Ref.no. 7-1111xx

TZ 111 Wallet of 4, assorted: black, red, blue and green
Ref.no. 7-111194

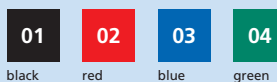

Refill ink

Refill ink for board markers:
25 ml bottle, capillary system

- Simply insert the tip of the marker into the refill bottle and after a few minutes the marker is ready for writing again
- Cap Off ink protects against rapid drying out

Ref.no. 7-1195xx

- High quality, low odour, quick drying, alcohol based ink
- Easily removed from all whiteboard surfaces
- Just add the right colour code to Ref.no.

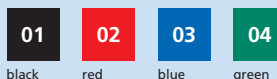

Refill ink for board markers:
100 ml bottle

- Dropper for precision filling
- Cap Off ink protects against rapid drying out

Ref.no. 7-1199xx



Refill ink for Legamaster retractable board marker TZ 14

- 25 ml bottle, capillary system
- Simply insert the tip of the marker into the refill bottle and after a few minutes the marker is ready for writing again

Ref.no. 7-1129xx

An environmentally-friendly solution: recycle your marker by using the refill ink!



Whiteboard eraser TZ 4



- Dry erasers for quick cleaning of boards
- Modern design
- Good grip
- Extra-wide magnetic strip for excellent board adhesion
- Colour: anthracite
- Approx. L 17 x W 7 cm

Ref.no. 7-120500

Refill tissues

- Suitable for TZ 4 erasers
- Available in boxes of 100
- 100% viscose tissue
- Biodegradable

Ref.no. 7-120600



Small whiteboard eraser

- Dry erasers for quick cleaning of boards
- Contains integrated magnet for board adhesion
- With replaceable tissue
- Cellulose fabric tissues
- Colour: white
- Dimensions approx. L 14.3 x W 4.8 cm



Ref.no. 7-120100



Eraser tissues

- Tissues for small eraser
- Pack of 100
- Biodegradable

Ref.no. 7-120200



Magnetic whiteboard eraser

- Dry erasers for quick cleaning of boards
- Contains integrated magnet for board adhesion
- Pads come with Velcro strip for quick changeover
- Felt strips
- Colour: white
- Dimensions approx. L 14 x W 4.5 x H 3.5 cm



Ref.no. 7-120300

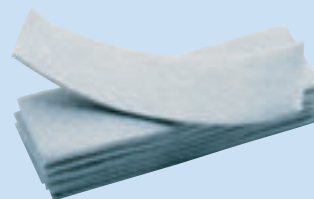

Eraser pads

- Pads for magnetic eraser
- Pack of 10

Ref.no. 7-120400



ACCESSORIES

Keep your board as new
with these
easy-to-use cleaners.



TZ 6 Whiteboard cleaner

- For regular, thorough cleaning of whiteboards and planning boards
- Practical non-aerosol pump spray system
- Detergent surfactant in alcohol solution
- Quick-drying

TZ 6 150 ml can
Ref.no. 7-121000

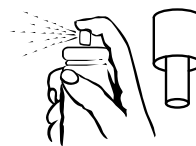
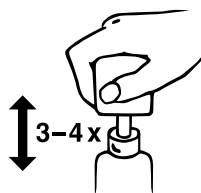

TZ 7 / TZ 8 Whiteboard cleaner

- For regular, thorough cleaning of whiteboards and planning boards
- Atomizer
- Detergent surfactant in alcohol solution
- Quick-drying

TZ 7 125 ml bottle
Ref.no. 7-121200

TZ 8 250 ml bottle
Ref.no. 7-121300



TZ 66 Whiteboard cleaning wipes

- Moist, lint-free disposable wipes
- Perforated tear-off edge; tissues are dispensed one by one
- Dispenser
- Moistened with detergent surfactant in alcohol solution
- Quick-drying

100 tissues
Ref.no. 7-121400



MagicWipe



Specifically for use on enamel board surface, look for the logo enamel / ceramic steel on the surface of your Legamaster board



- For intensive whiteboard cleaning
- Wipes away the toughest marks and stains, even permanent marker ink
- Ready to use: only requires a drop of water or Legamaster whiteboard cleaner
- MagicWipe may fade non enamel board surfaces
- Material: micro fibre, washable at 60 °
- Environmentally friendly; 100% recyclable
- Contents: 2 MagicWipes + 1 drying towel

Ref.no. 7-121500



Specifically for use on enamel board surface.

Board assistant

- Suitable for all magnetic boards
- Magnetic
- Container and eraser in one
- Container lid doubles as board eraser
- Modern design
- Colour: anthracite
- Suitable for all Legamaster board markers
- Markers not included

Ref.no. 7-122500



Marker holder

- Suitable for all magnetic boards
- Magnetic
- Stores markers in a horizontal position
- Holds 4 board markers
- Suitable for all Legamaster board markers except for TZ 180
- Markers not included

Ref.no. 7-122000



ACCESSORIES

PROFESSIONAL kit Board accessory

- Quality kit for all whiteboards
- Extensive range of boxed accessories
- Contents:
 - Set of 10 board markers TZ 1 (one of each in: black, red, blue, green, yellow, orange, brown, purple, pink, light blue)
 - 1 board assistant (container and eraser)
 - 50 dry-wipe tissues
 - 1 whiteboard cleaner TZ 6, 150 ml
 - 10 magnets 30 mm diameter
 - 5 super-strength magnets, 35 mm diameter



Ref.no. 7-125500

Magnetic strength
≈ 850 g



Magnetic strength
≈ 2500 g (super)



Tip:
Stroke width:
approx. 1.5 – 3.0 mm

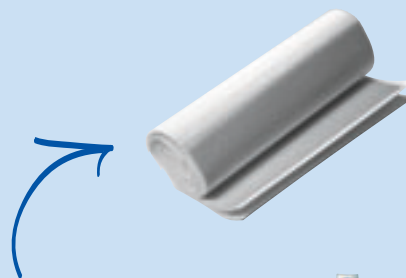

- 100% viscose tissue
- Biodegradable



- Practical non-aerosol pump spray system
- Quick-drying



- Suitable for all magnetic boards
- Container and eraser in one
- Container lid doubles as board eraser
- Dry erasers for quick cleaning of boards

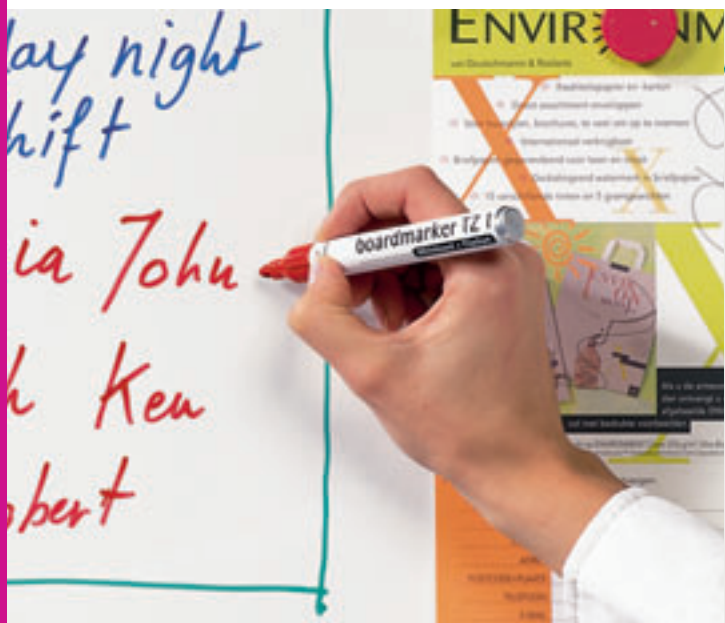

STARTER kit Board accessory

- Complete kit for whiteboards
- Boxed selection of indispensable accessories
- Contents:
 - Set of 4 board markers TZ 100 (one of each in: black, red, blue, green)
 - 1 marker holder
 - 1 small whiteboard eraser
 - 10 dry-wipe tissues
 - 1 whiteboard cleaner TZ 7, 125 ml
 - 10 magnets 30 mm diameter

Ref.no. 7-125000





Magnetic strength ≈ 850 g

- Tissues for small eraser
- Biodegradable
- Atomizer
- Quick-drying
- Dry erasers for quick cleaning of boards
- Contains integrated magnet for board adhesion
- With replaceable tissue

Tip:

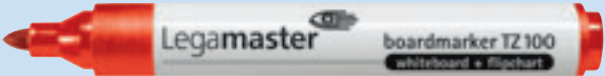
 Stroke width:
 approx. 1.5 – 3.0 mm

CAP OFF



- Suitable for all magnetic boards
- Stores markers in a horizontal position
- Holds 4 board markers

BASIC kit Board accessory

- Basic set for whiteboards
- Boxed selection of indispensable accessories
- Contents:
 - 4 TZ 100 board markers (one of each in: black, red, blue, green)
 - 1 small whiteboard eraser
 - 1 whiteboard cleaner TZ 7, 125 ml
 - 4 magnets 30 mm diameter

Ref.no. 7-125100



Magnetic strength ≈ 850 g

- For use on whiteboards and flipcharts
- Dry erasers for quick cleaning of boards
- Contains integrated magnet for board adhesion

CAP OFF



- Atomizer
- Quick-drying

ACCESSORIES

TZ 41 Presentation marker

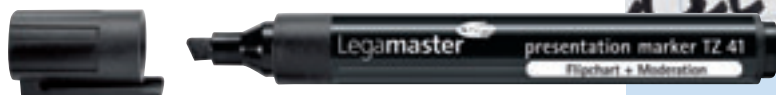

- Specially for use on flipchart paper pads
- Special bleed-proof odourless ink
- Ink will not bleed through paper
- Chisel tip for bold downstrokes and stylish lettering
- Also suitable for moderation purposes
- For refilling this marker use the 100 ml refill ink bottle
Ref.no. 7-1558xx, capillary system
- Special water-based ink

Tip:



Stroke width:
approx. 2.0 – 5.0 mm

TZ 41 Box of 10, available in single colour
Please state colour code with order
Ref.no. 7-1550xx

TZ 41 Wallet of 4, assorted: black, red, blue and green
Ref.no. 7-155094

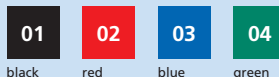

JUMBO TZ 48 Presentation marker



- Specially for use on flipchart paper pads
- Special bleed-proof odourless ink
- Chisel tip for thicker downstrokes
- Also suitable for moderation purposes
- For refilling this marker use the 100 ml refill ink bottle
Ref.no. 7-1559xx, dropper system
- Special water-based ink

Tip:



Stroke width:
approx. 4.0 – 12.0 mm

TZ 48 Box of 10, available in single colour
Please state colour code with order
Ref.no. 7-1555xx

TZ 48 Wallet of 4, assorted: black, red, blue and green
Ref.no. 7-155594



Refill ink for presentation markers



For presentation marker TZ 41,
capillary system
Ref.no. 7-1558xx



For presentation marker TZ 48,
dropper for precision filling
Ref.no. 7-1559xx

- Refilling your marker is environmentally friendly
- Special bleed-proof odourless ink
- 100 ml bottle
- Cap Off ink protects against rapid drying out
- Just add the right colour code to Ref.no.

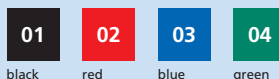



Flipchart accessory STARTER kit

- A practical all-in-one accessory set for your flipchart
- Includes paper as well as accessories
- Includes a free small booklet with "tips and tricks" on:
 - how to use the accessories best in combination with your flipchart
 - how to use flipchart paper efficiently
 - how to write clear and clean on paper charts with our special Legamaster markers
 - and much more!

- Contents:
 - 3 flipchart paper pads 20 sheets plain
 - set of 2 presentation markers TZ 48 (one of each colour: black, red)
 - set of 4 presentation markers TZ 41 (one of each colour: black, red, blue, green)
 - 4 magnets 30 mm
 - 1 free booklet with tips and tricks



Ref.no. 7-124900

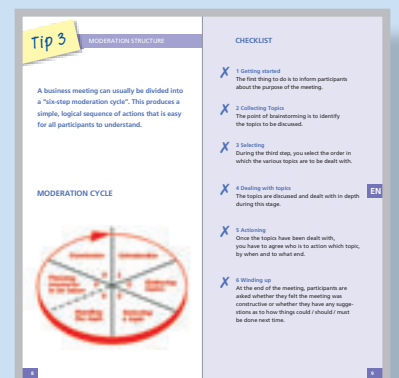
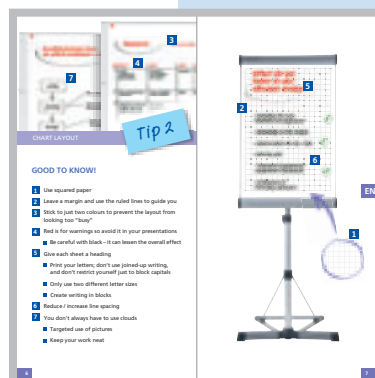
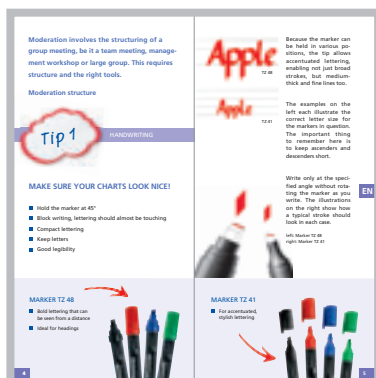
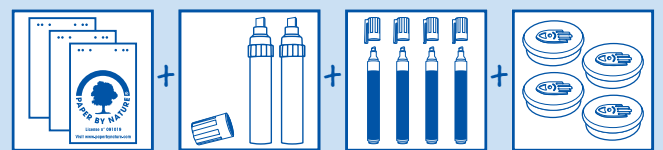

ACCESSORIES

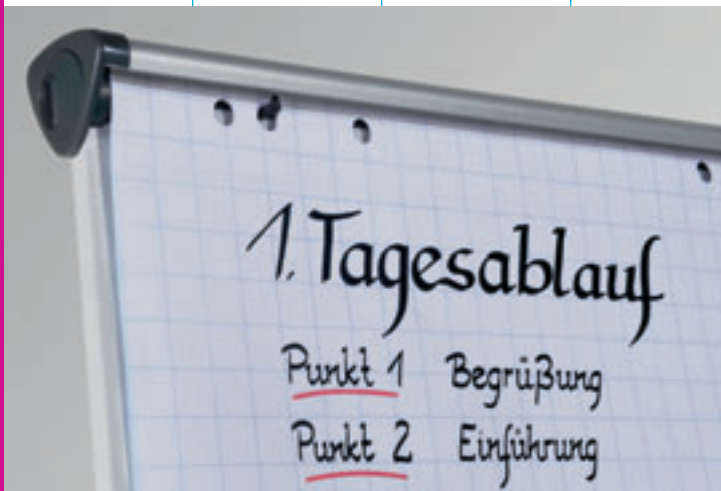

Flipchart paper

- 20-sheet paper pads
- Wood-free, white paper
- Pack of 5 pads
- Perforations enable individual sheets to be torn off easily
- Sheet size: 98 x 65 cm
- 80 gsm
- Chlorine-free, bleached paper



Sheet	Grid size	Ref.no.
Plain	–	7-156000
Grid	2.5 x 2.5 cm	7-156500



Paper roll for SILVERTEC mobile

- Paper roll for SILVERTEC mobile flipchart
- 35 m roll
- Wood-free, white paper
- 80 gsm
- Chlorine-free, bleached paper

Ref.no. 7-156900



Flipchart pad holder

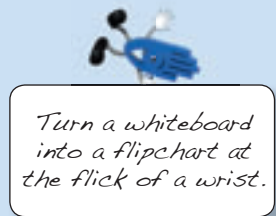



- For flipchart paper pads
- Magnetic
- Adjustable to suit all major standard pad formats
- Aluminium
- H 7 x W 70 cm

Ref.no. 7-123000



Magic-Chart

- Ready to use solution for every spontaneous or planned meeting
- Creates an instant writing surface, even when a whiteboard or flipchart are not available
- Electrostatic foil easily sticks to almost any surface (wood, concrete, glass, wallpaper)
- Long lasting electrostatic product properties (up to 5 years!)
- No adhesive required, leaves no traces
- Sheets can be repositioned easily
- Presentation cards and notices will stick without help simply by smoothing them onto the foil
- Environmentally friendly: fully recyclable
- Roll width 60 cm, perforations every 80 cm, 25 sheets
- Including marker

Magic-Chart	Grid size	Ref.no.
	–	7-159100
	–	7-159200
	2.5 x 2.5 cm	7-159000



Produced in an environmentally friendly way and completely recyclable

Magic-Chart whiteboard

- Can be written on using Legamaster board markers and edding permanent markers
- Permanent markers guarantee a more intensive ink colour (longer drying time)
- Erasable when used in combination with Legamaster board markers
- Environmentally friendly: one sheet can be used up to 10 times!

Magic-Chart flipchart

- Grid size 2.5 x 2.5 cm
- Can be written on using Legamaster board markers and edding permanent markers

Magic-Chart blackboard

- Can be used:
 - to black out/darken windows
 - to darken a room in case bright sun light makes it difficult to give a beamer presentation
 - to create a chalk board effect; e.g. present a restaurant menu in an original way
- Can be written on using:
 - edding neon board markers
 - edding paint markers
- Highest electrostatic properties



Magic-Chart whiteboard

Fully white Magic-Chart foil (whiteboard effect), glossy look

Magic-Chart flipchart

Fully gridded Magic-Chart foil (flipchart effect)

Magic-Chart blackboard

Fully black Magic-Chart foil (black chalkboard effect)

Push-Pins

- Push-pins in assorted colours
- Easy to use
- 5 colours: black, red, blue, green and white

Pack of 50
Just add the right colour code to Ref.no.
Ref.no. 7-1451xx

Pack of 200, assorted
Ref.no. 7-145299

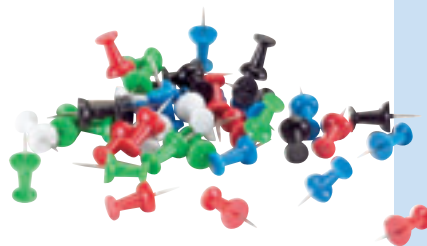

Moderation pins – Roundhead pins

- Extra thick 6 mm head for maximum grip
- Assorted pack of various colours
- Pack of 200
- Diam. 6 mm x L 15 mm

Ref.no. 7-241099

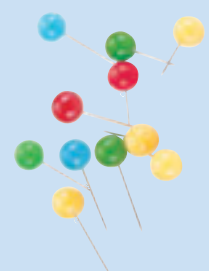

ACCESSORIES

Coloured magnets



- Available colours: black, red, blue, green, yellow and white
- Pack of 10
- Just add the right colour code to Ref.no.

Diameter	Magnetic strength	Ref.no.
10 mm	≈ 150 g	7-1810xx
20 mm	≈ 250 g	7-1811xx
30 mm	≈ 850 g	7-1812xx

01	02	03	04	05	19
black	red	blue	green	yellow	white

Diameter	Magnetic strength	Ref.no.
35 mm	≈ 1000 g	7-1813xx
35 mm	≈ 2500 g (super)	7-1814xx

01	02	03	04	19
black	red	blue	green	white

Magnetic strips



- Self adhesive on one side
- Notes and pictures can be attached to the steel strip with magnets
- Set of 10

Size	Ref.no.
5 x 100 cm	7-185400

Self-adhesive magnetic tape



- Magnetic to all steel-based surfaces
- Turn objects into magnets simply by attaching a strip of tape
- Self-adhesive on one side
- Permanent magnetic on the other side
- Magnetic strength approx. 70 g/cm²
- 1.5 mm thickness
- 1 roll, brown

Size	Ref.no.
12.5 mm x 3 m	7-186100
19.0 mm x 3 m	7-186300
25.0 mm x 3 m	7-186500

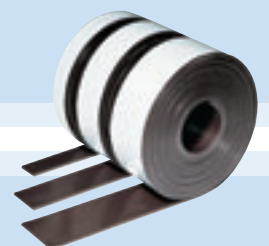

Magnetic sheets



- Magnetic to all steel-based surfaces
- Can be cut into individual shapes and symbols
- For marking and labelling all kinds of objects, e.g. shelves, etc.
- Magnetic strength approx. 35 g/cm²
- Approx. 0.7 mm thickness
- 1 sheet, white

Size	Ref.no.
200 x 300 mm	7-189000

Magnetic labelling tape



- Magnetic to all steel-based surfaces
- Handy roll; various widths available
- Cut chosen length from the roll
- For marking and labelling all kinds of objects, e.g. shelves, etc.
- Magnetic strength approx. 32 g/cm²
- Approx. 0.6 mm thickness
- 1 roll, white

Size	Ref.no.
20 mm x 3 m	7-187200
30 mm x 3 m	7-187400
40 mm x 3 m	7-187500
50 mm x 3 m	7-187600

Magnetic blocks

- Use to attach boards to steel-system walls and partitions
- Self-adhesive, magnetic blocks
- For boards with a steel backing only
- Peel off the liner from the magnet and press the magnet firmly with the adhesive side to the backside of the board
- The magnetic part must be attached to the steel wall



- The blockmagnet is provided with a rubber coating which increases the magnetic force. This coating also prevents damage to the walls
- Place the magnets in a triangle on the backside of the board for a better grip
- Suitable for the following Legamaster boards: DYNAMIC, IMAGINE, PROFESSIONAL, PREMIUM^{PLUS}, PREMIUM, UNIVERSAL^{PLUS}
- Approx. 53 x 78 x 13 mm
- Number of magnets needed:
 - board size 60 x 90 cm = 4
 - board size 90 x 120 cm = 5
 - board size 90 x 180 cm = 7

Ref.no. 7-184000

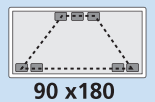
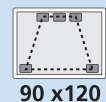

Boards which can be mounted with magnetic blocks, can be identified through the following logo:



ACCESSORIES

Magnetic document holders

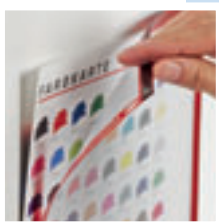

- Simple and fast switching of documents
- Magnetic document holders for attaching to a (white)board
- Systematically present your messages on a whiteboard or any other steel surface
- Magnetic backside strips on three sides of the holder
- Can be used horizontally or vertically
- UV protection
- Transparent foil surface
- Packed per 5 pieces
- Coloured border: available in black, red, blue and green
- Just add the right colour code to Ref.no.

DIN	Ref.no.
A4	7-6356xx

01	02	03	04
black	red	blue	green

Magnetic strips

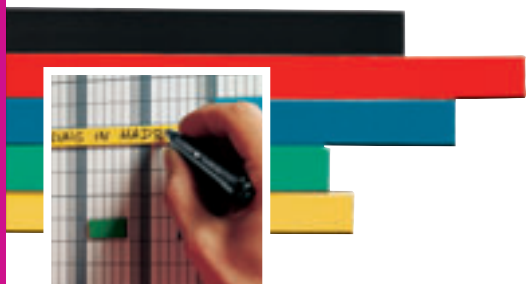

- For highlighting longer planning periods
- Will accept non-permanent OHP pens (wipe with damp cloth) or board markers (dry-wipe)
- Magnetic strength approx. 50 g/cm²
- Approx. 1.7 mm thickness
- Available colours: black, red, blue, green, yellow
- Just add the right colour code to Ref.no.

Size	Set of	Ref.no.
5 x 300 mm	12	7-4401xx
10 x 300 mm	6	7-4402xx

01	02	03	04	05
black	red	blue	green	yellow



Magnetic sheets



- Easy for cutting out individual shapes and symbols
- Magnetic strength approx. 50 g/cm²
- Approx. 1.7 mm thickness
- Available colours: black, red, blue, green, yellow
- 1 sheet
- Just add the right colour code to Ref.no.

Size	Ref.no.
240 x 320 mm	7-4410xx

01	02	03	04	05
black	red	blue	green	yellow

Date line



- Marks the day's date
- Length adjustable to fit all board sizes
- Magnetic date line for unlimited use on all magnetic boards

Ref.no. 7-430000

Magnetic symbols / shapes

Squares:

- Available in 2 colours: red and yellow
- 1.7 mm thick, permanently magnetic
- Magnetic strength 50 g/cm²

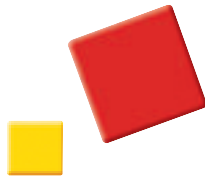

Size	Set of	Colour	Ref.no.
10 x 10 mm	96	red	7-442102
10 x 10 mm	96	yellow	7-442105
20 x 20 mm	24	red	7-442202
20 x 20 mm	24	yellow	7-442205

Rectangles:

- Available in 2 colours: red and yellow
- 1.7 mm thick, permanently magnetic
- Magnetic strength 50 g/cm²

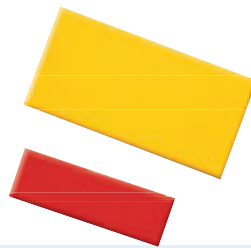

Size	Set of	Colour	Ref.no.
10 x 20 mm	48	red	7-444102
10 x 20 mm	48	yellow	7-444105
10 x 30 mm	32	red	7-444202
10 x 30 mm	32	yellow	7-444205
20 x 30 mm	16	red	7-444402
20 x 30 mm	16	yellow	7-444405
20 x 60 mm	8	red	7-444602
20 x 60 mm	8	yellow	7-444605
30 x 60 mm	6	red	7-444702
30 x 60 mm	6	yellow	7-444705
30 x 80 mm	4	red	7-444802
30 x 80 mm	4	yellow	7-444805
40 x 80 mm	3	red	7-444902
40 x 80 mm	3	yellow	7-444905

Circles:

- Available in 2 colours: red and yellow
- 1.7 mm thick, permanently magnetic
- Magnetic strength 50 g/cm²

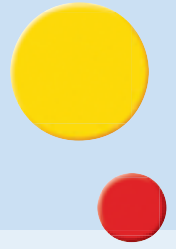

Size	Set of	Colour	Ref.no.
Ø 10 mm	54	red	7-443102
Ø 10 mm	54	yellow	7-443105
Ø 20 mm	15	red	7-443202
Ø 20 mm	15	yellow	7-443205

Triangles:

- Available in red
- 1.7 mm thick, permanently magnetic
- Magnetic strength 50 g/cm²

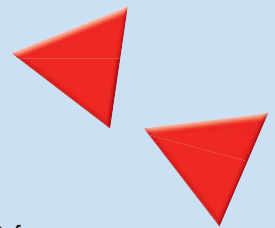

Size	Set of	Colour	Ref.no.
10 x 10 x 10 mm	207	red	7-445102

Arrows:

- Available in red
- 1.7 mm thick, permanently magnetic
- Magnetic strength 50 g/cm²



Size	Set of	Colour	Ref.no.
10 x 20 mm	35	red	7-446102
20 x 35 mm	12	red	7-446202

Assorted magnetic symbols:

- Available in 5 colours: black, red, blue, green, yellow
- 1.7 mm thick, permanently magnetic
- Magnetic strength 50 g/cm²
- Just add the right colour code to Ref.no.

Size	Set of	Ref.no.
approx. 10 mm high	70	7-4481xx
approx. 20 mm high	30	7-4482xx



01	02	03	04	05
black	red	blue	green	yellow

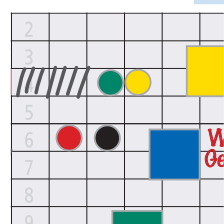
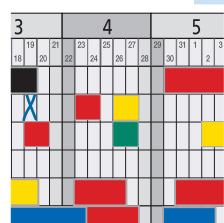
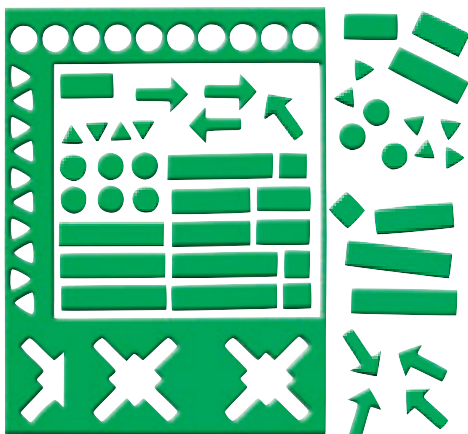

ACCESSORIES

Magnetic label holders



- Suitable for all grid boards and planning boards
- Flat C-profile for inserting written labels
- Includes set of white labels

Size	Quantity/set	Ref.no.
10 x 60 mm	72	7-450100
15 x 60 mm	63	7-450200
20 x 60 mm	54	7-450400
30 x 60 mm	36	7-450600
30 x 90 mm	24	7-450700
30 x 120 mm	18	7-450800

Label inserts



- Quick and easy to insert
- For label holders
- Colour: white

For label holder	Quantity/set	Ref.no.
10 x 60 mm	225	7-455119
15 x 60 mm	120	7-455219
30 x 60 mm	60	7-455619
30 x 90 mm	40	7-455719
30 x 120 mm	30	7-455819

- Quick and easy to insert
- For label holders
- Colours: red, blue, green, yellow, pink, white
- Just add the right colour code to Ref.no.

For label holder	Quantity/set	Ref.no.
20 x 60 mm	90	7-4554xx

02	03	04	05	09	19
red	blue	green	yellow	pink	white

Divider tape for planboards

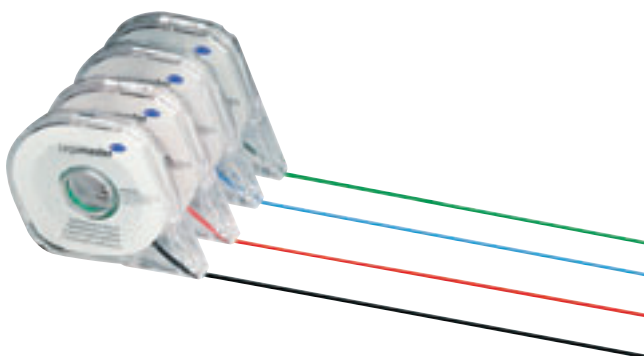

- A quick and accurate way of dividing columns and rows
- Self-adhesive, available in available in black, red, blue and green
- Useful accessory for grid and planning boards
- Just add the right colour code to Ref.no.

Size	Ref.no.
1.0 mm x 16 m	7-4331xx
2.5 mm x 16 m	7-4332xx
3.0 mm x 8 m	7-4333xx

01	02	03	04
black	red	blue	green

Date strip sets

Date strip set 1:

- For year planner
Ref.no. 7-406000
- Breaks down into 7 day week divisions and 365 day grids using the six month format

Ref.no. 7-431100

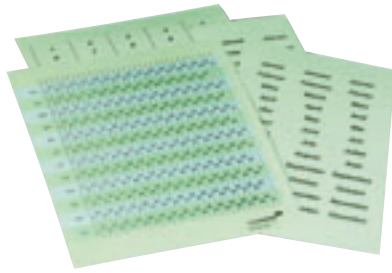

Date strip set 2:

- For year planner
Ref.no. 7-404100,
Ref.no. 7-404200,
Ref.no. 7-404300
- Breaks down into 5 day week divisions
- This set covers the years 2012 up to and including 2014

Ref.no. 7-431200



Date strip set 3:

- For year planner
Ref.no. 7-405000
- Breaks down into 7 day week divisions and 365 day grids

Ref.no. 7-431300



Planning sets



Planning set 1:

- For personal planning

Ref.no. 7-435100



Planning set 2:

- For up to 40 people / events / projects

Ref.no. 7-435200



Planning set 3:

- For up to 75 people / events / projects

Ref.no. 7-435300

- Contents:
 - 12 month strips (dates 1-31), alternating in blue and green
 - Calendar week numbers 1-53
 - Names of the months in five languages: German, English, French, Swedish and Dutch

- Contents:
 - Strips with 12 month dates (1-31); applicable for specifically three years
 - 5-day week strips (1st letter of the days: M-F); applicable for any week and month. The week strips are delivered in English, German, Dutch, French and Swedish

- Contents:
 - 12 month indicators (January...etc.) in English, German, Dutch, French and Swedish
 - Strips with 12 month dates (1-31); applicable for any year
 - Calendar week numbers (1-53)
 - 7-day week strips (1st letter of the days: M-F); applicable for any week and month. The week strips are delivered in English, German, Dutch, French and Swedish

- Contents:
 - 1 wallet of TZ 140 / set of 4 board markers, assorted
 - 1 OHP pen edding 152 M (black)
 - 12 magnetic strips (10 x 300 mm)
3 each in red, blue, green and yellow
 - 120 assorted magnetic symbols (20 mm)
30 each in red, blue, green and yellow

- Contents:
 - 1 wallet of TZ 140 / set of 4 board markers, assorted
 - 1 OHP pen edding 152 M (black)
 - 12 magnetic strips (10 x 300 mm)
3 each in red, blue, green and yellow
 - 280 assorted magnetic symbols (10 mm)
70 each in red, blue, green and yellow,
 - 40 label holders (10 x 60 mm)
 - 6 sheets of labels: 1 sheet each in yellow, pink, red, green, blue and white (45 labels per sheet)

- Contents:
 - 1 wallet of TZ 140 / set of 4 board markers, assorted
 - 1 OHP pen edding 152 M (black)
 - 24 magnetic strips (10 x 300 mm)
6 each in red, blue, green and yellow
 - 280 assorted magnetic symbols (10 mm)
70 each in red, blue, green and yellow
 - 10 label holders (20 x 60 mm)
 - 3 sheets of labels:
 - 1 sheet each in yellow, white, green (18 labels per sheet)
 - 75 label holders (10 x 60 mm)
 - 12 sheets of labels: 2 sheets each in yellow, pink, red, green, blue and white (45 labels per sheet)

ACCESSORIES

Laser pointer LX 3



Laserpointer	Length	Laser class	Weight incl. batteries	Ref.no.
LX 3 green	15 cm	2	71 g	7-575600



Caution:

*Laser radiation -
Do not stare into beam!*

The eye is 20 times more sensitive to a green colour than a red colour. Therefore a green laser pointer is particularly suitable for use in a daylight situation or on a brightly lit screen. The green dot is very bright and piercing and has a very long range.

For use in an office, classroom or conference environment.

- Best laser pointer tool for high brightness screens and big display presentations
- Laser pointer with a green dot, Ø 1.4 cm
- By pushing the button the green laser dot is activated
- Green laser beam; high visibility (twenty times higher than a red laser beam)
- Silver metal casing
- Practical pen-clip
- Soft structured grip zone
- Range: 200 m
- Laser class 2, power < 1 mW
- CE-approved
- Certified to standard EN 60825-1
- Comes complete with case, 2 AAA batteries and a user manual

Laser pointer LX 1, LX 2 and LX 4



Laserpointer	Length	Laser class	Weight incl. batteries	Ref.no.
LX 1	10 cm	2	60 g	7-575300
LX 2	14 cm	2	56 g	7-575500
LX 4	14 cm	2	54 g	7-575700

- Power: <1 mW
- Red laser dot, diameter approx. 4 mm
- Certified to standard EN 60825-1
- Range: 100 m
- CE tested
- Comes complete with case and batteries

Laserpointer LX 1:

- Black metal casing
- Green on / off button
- Handy size
- Battery: (N) battery SUM5R1



Laserpointer LX 2:

- Silver metal casing
- Red on / off button
- Sturdy
- Battery: (AAA) battery SUM4R03

Laserpointer LX 4:

- Silver metal casing
- Red on / off button
- Red laser dot: can be turned into an arrow by twisting the laser head
- Battery: (AAA) battery SUM4R03



Small telescopic pointer



- Pointer with integrated ballpoint
- Chrome-plated
- 13 cm long
- Extends to 62.5 cm
- Cash & carry packaging

Ref.no. 7-570000





Letters and numbers

- White plastic letters
- Box size: L 36 x W 25 x H 5 cm

Boxes full of character:

- Indispensable for use with PREMIUM information boards
- Each character supplied in a quantity designed to reflect its frequency of use
- Box with separate compartments for each letter
- For contents, see below

Letter height	Characters	Ref.no.
H 12 mm	576	7-605100
H 20 mm	560	7-605200
H 30 mm	384	7-605300

Supplementary sets:

- Complete set of letters, numbers and characters in all available sizes
- This box contains half of the quantity mentioned below
- It is only possible to order the complete box of supplements

Letter height	Characters	Ref.no.
H 12 mm	288	7-606100
H 20 mm	280	7-606200
H 30 mm	192	7-606300

Letter height	A	B	C	D	E	F	G	H	I	J	K	L	M	N	O	P	Q	R	S	T	U	V	W	X	Y	Z
H 12 mm	24	8	8	16	32	8	8	8	16	8	16	16	16	24	16	8	8	16	16	16	16	16	8	8	8	8
H 20 mm	24	8	8	16	32	8	8	8	16	8	16	16	8	24	16	8	8	16	16	16	16	16	8	8	8	8
H 30 mm	16	8	8	8	16	8	8	8	8	8	8	8	8	16	8	8	8	8	8	8	8	8	8	8	8	8

Letter height	1	2	3	4	5	6	7	8	9	0	.	,	!	?	()	/	-	-	"	€					
H 12 mm	16	8	8	8	16	8	8	8	8	16	24	24	8	8	8	8	8	8	8	8	8	8	8	8	8	8
H 20 mm	16	8	8	8	16	8	8	8	8	8	24	24	8	8	8	8	8	8	8	8	8	8	8	8	8	8
H 30 mm	8	8	8	8	8	8	8	8	8	8	16	8	8	8	8	8	8	-	-	-	8	8	8	8	8	8



SERVICE

Matrix whiteboards

The stars provide a comparative indication of how well a certain feature or property is presented in the product.

Five stars means a feature is represented very well in the product. One star means the feature is present, but may not be a unique advantage of the product.

Glassboard PURE
Ref.no. 7-1007xx
page 10

DYNAMIC whiteboard
Ref.no. 7-1009xx
page 11

IMAGINE whiteboard
Ref.no. 7-1016xx
page 12

PROFESSIONAL whiteboard
Ref.no. 7-1000xx
page 14

PROFESSIONAL gridboard
Ref.no. 7-1001xx
page 14

PROFESSIONAL conference unit
Ref.no. 7-1003xx
page 15

PROFESSIONAL revolving whiteboard
Ref.no. 7-1004xx
page 15

PREMIUMPLUS whiteboard
Ref.no. 7-1010xx
page 16

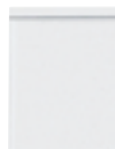

1 Surface

Guarantee on write on / dry wipe board surface



Board surface

Optical white safety glass

Top quality enamel steel

Top quality enamel steel

Top quality enamel steel

Top quality enamel steel

Top quality enamel steel

Top quality enamel steel

Top quality enamel steel

Scratch resistant

☆☆☆☆☆

☆☆☆☆☆

☆☆☆☆☆

☆☆☆☆☆

☆☆☆☆☆

☆☆☆☆☆

☆☆☆☆☆

☆☆☆☆☆

Easy to clean

☆☆☆☆☆

☆☆☆☆☆

☆☆☆☆☆

☆☆☆☆☆

☆☆☆☆☆

☆☆☆☆☆

☆☆☆☆☆

☆☆☆☆☆

Magnetic board surface



✓*

✓

✓

✓

✓

✓

✓

✓

2 Features

Suitable for long term / intensive use

☆☆☆☆☆

☆☆☆☆☆

☆☆☆☆☆

☆☆☆☆☆

☆☆☆☆☆

☆☆☆☆☆

☆☆☆☆☆

☆☆☆☆☆

Aluminium frame

✓

✓

✓

✓

✓

✓

✓

Mounting system

Special wall mount for glass boards

Special wall mount for design boards

Easy wall mounting, concealed slot system

Easy wall mounting, concealed slot system

Easy wall mounting, concealed slot system

Easy wall mounting, concealed slot system

Easy wall mounting, concealed slot system

Light-weight

☆☆

☆☆☆☆

☆☆☆

☆☆☆☆

☆☆☆☆

☆☆☆

☆☆☆☆

☆☆☆

Mobile stand

✓

Can be mounted horizontally and vertically

✓

✓

✓

3 Accessories included

Marker tray

✓

✓

✓

✓

✓

✓

✓

Board marker

✓ (4 markers, 1 eraser)

✓

✓

✓

✓

✓

✓

Fixing kit / hanging system

✓ (mounting aluminium profiles only)

✓

✓

✓

✓

✓

✓

✓

* Only for use with special glassboard magnets

PREMIUM
whiteboard
Ref.no. 7-1020xx
page 16

UNIVERSAL^{PLUS}
whiteboard
Ref.no. 7-1021xx
page 17

UNIVERSAL
whiteboard
Ref.no. 7-1022xx
page 17

ECONOMY^{PLUS}
whiteboard
Ref.no. 7-1027xx
page 18

ECONOMY
white- and combiboard
Ref.no. 7-1028xx / 7-1024xx
page 18 + 21

ECONOMY^{PLUS}
conference unit
Ref.no. 7-1005xx
page 19

ECONOMY
conference unit
Ref.no. 7-1002xx
page 19

ECONOMY^{PLUS}
revolving whiteboard
Ref.no. 7-1035xx
page 20

ECONOMY
revolving whiteboard
Ref.no. 7-1036xx
page 20

ACCENTS
linear whiteboard
Ref.no. 7-1031xx
page 21

BASIC
whiteboard
Ref.no. 7-1029xx
page 22

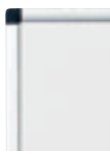

Lacquered steel

Enamel steel

Lacquered steel

Enamel steel

Lacquered steel

Enamel steel

Lacquered steel

Enamel steel

Lacquered steel

Lacquered steel

Melamine

☆☆☆

☆☆☆☆

☆☆☆

☆☆☆☆

☆☆☆

☆☆☆☆

☆☆☆

☆☆☆☆

☆☆☆

☆☆☆

☆☆

☆☆☆☆

☆☆☆☆☆☆

☆☆☆

☆☆☆☆☆☆

☆☆☆

☆☆☆☆☆☆

☆☆☆

☆☆☆☆☆☆

☆☆☆

☆☆☆

☆☆

✓

✓

✓

✓

✓

✓

✓

✓

✓

✓

☆☆☆☆

☆☆☆☆

☆☆☆

☆☆☆☆

☆☆☆

☆☆☆☆

☆☆☆

☆☆☆☆

☆☆☆

☆☆☆

☆☆

✓

✓

✓

✓

✓

✓

✓

✓

✓

✓

✓

Easy wall mounting, concealed slot system

Corner wall mount

Corner wall mount

Wall mounting

Wall mounting

Wall mounting with L-hooks

Wall mounting with L-hooks

Wall mounting

Wall mounting

Wall mounting

Corner wall mount

☆☆☆

☆☆☆

☆☆☆

☆☆☆☆

☆☆☆☆

☆☆☆

☆☆☆

☆☆☆

☆☆☆

☆☆☆☆☆☆

☆☆☆☆

✓

✓

✓

✓

✓

✓

✓

✓

✓

✓

✓

✓

✓

✓

✓

✓

✓

✓

✓

✓

✓

✓

✓

✓

✓

✓

✓

✓

✓

✓

✓

✓

✓

✓

✓

✓

✓

✓

✓

✓

✓

SERVICE

Matrix pinboards

The stars provide a comparative indication of how well a certain feature or property is presented in the product.

Five stars means a feature is represented very well in the product. One star means the feature is present, but may not be a unique advantage of the product.

**DYNAMIC
felt pinboard**
Ref.no. 7-1402xx
Ref.no. 7-1403xx
page 24

**PROFESSIONAL
lino-cork bulletin
pinboard**
Ref.no. 7-1401xx
page 25

**PROFESSIONAL
felt pinboard**
Ref.no. 7-1405xx
Ref.no. 7-1406xx
page 25



1 Surface

Board surface



Blue or grey
durable felt

Light grey
cork linoleum

Blue or grey
durable felt

Suitable for long term / intensive use

☆☆☆☆☆

☆☆☆☆☆

☆☆☆☆☆

2 Materials

Aluminium frame



Mounting system

Special
wall mount
for
design boards

Easy
mounting system
with concealed
slot system

Easy
mounting system
with concealed
slot system

Can be placed horizontally and vertically



3 Accessories included

Fixing kit



**PREMIUM
felt pinboard**
Ref.no. 7-1415xx
Ref.no. 7-1416xx
page 26



**PREMIUM
cork pinboard**
Ref.no. 7-1410xx
page 26



**UNIVERSAL
felt pinboard**
Ref.no. 7-1418xx
Ref.no. 7-1419xx
page 27



**UNIVERSAL
cork pinboard**
Ref.no. 7-1420xx
page 27



Board surface	Blue or grey durable felt	Durable natural cork	Blue or grey felt	Natural cork
Suitable for long term / intensive use	☆☆☆☆	☆☆☆	☆☆☆	☆☆
Aluminium frame	✓	✓	✓	✓
Mounting system	Easy mounting system with concealed slot system	Easy mounting system with concealed slot system	Corner wall mount	Corner wall mount
Can be placed horizontally and vertically	✓	✓	✓	✓
Fixing kit	✓	✓	✓	✓



SERVICE

Matrix flipcharts

The stars provide a comparative indication of how well a certain feature or property is presented in the product.

Five stars means a feature is represented very well in the product. One star means the feature is present, but may not be a unique advantage of the product.

ORION flipchart
Ref.no. 7-150000
page 31



TAURUS flipchart
Ref.no. 7-1502xx
page 32



SILVERTEC mobile flipchart
Ref.no. 7-151000
page 33



IMAGINE flipchart
Ref.no. 7-1503xx
page 34



PROFESSIONAL flipchart tripod
Ref.no. 7-152000
page 34



PROFESSIONAL flipchart Triangle mobile
Ref.no. 7-153500
page 36



PREMIUM flipchart Triangle mobile
Ref.no. 7-153400
page 36



1 Surface

Guarantee on write on / dry wipe board surface



Board surface

High quality enamel steel

Lacquered steel

Silver coloured coating

High quality enamel steel

High quality enamel steel

Enamel steel

Lacquered steel

Suitable for long term / intensive use

★★★★★

★★★★★

★★★★★

★★★★★

★★★★★

★★★★★

★★★★★

Writing surface / Easy to clean

★★★★★

★★★★★

★★★★★

★★★★★

★★★★★

★★★★★

★★★★★

Magnetic board surface

✓

✓

✓

✓

✓

✓

✓

2 Features

Ergonomic design

★★★★★

★★★★★

★★★★★

★★★★★

★★★★★

★★★★★

★★★★★

Curved writing surface

✓

✓

✓

✓

✓

✓

✓

Stability

★★★★★

★★★★★

★★★★★

★★★★★

★★★★★

★★★★★

★★★★★

Easily height adjustable

★★★★★

★★★★★

★★★★★

★★★★★

★★★★★

★★★★★

★★★★★

Pad holder with tear-off edge

✓

✓

✓

✓

✓

✓

✓

Two extendable side arms

✓

✓

✓

✓

✓

✓

✓

One extendable side arm

✓

✓

✓

✓

✓

✓

✓

Suitable for paper roll as well as paper pads

✓

✓

✓

✓

✓

✓

✓

Suitable for various paper formats

✓

✓

✓

✓

✓

✓

✓

Mobile / with castors

✓

✓

✓

✓

✓

✓

✓

3 Accessories included

Marker tray

✓

✓

✓

✓

✓

✓

✓

Flipchart paper pad

✓

✓

✓

✓

✓

✓

✓

Paper roll

✓

✓

✓

✓

✓

✓

✓

Presentation marker

✓

✓

✓





✓

✓

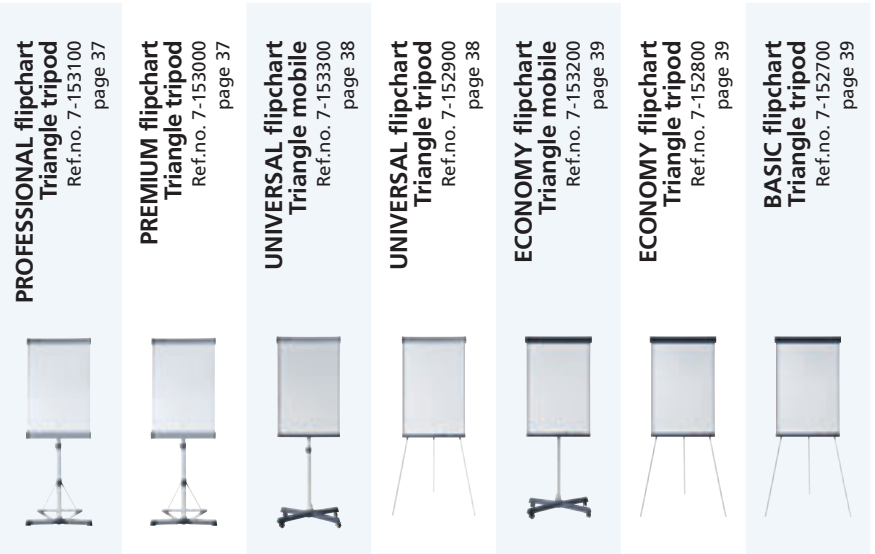
✓

✓



							
Guarantee on write on / dry wipe board surface	25 years guarantee	5 years guarantee	5 years guarantee	5 years guarantee	5 years guarantee	5 years guarantee	2 years guarantee
Board surface	Enamel steel	Lacquered steel	Lacquered steel	Lacquered steel	Lacquered steel	Lacquered steel	Melamine
Suitable for long term / intensive use	☆☆☆☆☆	☆☆☆☆☆	☆☆☆☆☆	☆☆☆☆☆	☆☆☆☆	☆☆☆☆	☆☆☆
Writing surface / Easy to clean	☆☆☆☆☆	☆☆☆☆☆	☆☆☆☆☆	☆☆☆☆☆	☆☆☆☆☆	☆☆☆☆☆	☆☆☆☆
Magnetic board surface	✓	✓	✓	✓	✓	✓	
Ergonomic design	☆☆☆☆☆	☆☆☆☆☆	☆☆☆☆☆	☆☆☆☆	☆☆☆☆☆	☆☆☆☆	☆☆☆☆
Curved writing surface							
Stability	☆☆☆☆	☆☆☆☆☆	☆☆☆☆☆	☆☆☆☆☆	☆☆☆☆☆	☆☆☆☆	☆☆☆☆
Easily height adjustable	☆☆☆☆☆	☆☆☆☆☆	☆☆☆☆☆	☆☆☆☆☆	☆☆☆☆☆	☆☆☆☆	☆☆☆☆
Pad holder with tear-off edge	✓	✓	✓	✓			
Two extendable side arms	✓	✓	✓	✓			
One extendable side arm							
Suitable for paper roll as well as paper pads							
Suitable for various paper formats	✓	✓	✓	✓	✓	✓	✓
Mobile / with castors			✓		✓		
Marker tray	✓	✓	✓	✓	✓	✓	✓
Flipchart paper pad							
Paper roll							
Presentation marker							

SERVICE

Matrix projection screens

The stars provide a comparative indication of how well a certain feature or property is presented in the product.

Five stars means a feature is represented very well in the product. One star means the feature is present, but may not be a unique advantage of the product.

1 Easy



Install (Easy Install)

CSR (controlled screen return)

Motor operation

2 Quality

TÜV

CE

Intensive use



Regular use



Occasional use



3 Width / height relation

1:1

1: 1 format

4:3

4: 3 format

16: 9 format

16:9

16:10 format

16:10

4 Black borders

1:1 aspect ratio: on the left and on the right side

4:3 / 16:10 / 16:9 aspect ratio: on the left, right, bottom and top

5 Remote control

RF (RF= radio frequency)



6 Optional accessories

7-554500 Ceiling brackets for PROFESSIONAL and PREMIUM M6 100 cm

7-555200 Ceiling brackets for PROFESSIONAL M8 100 cm

7-555100 Wall brackets PROFESSIONAL and PREMIUM 75 cm

7-545400 Wall brackets PROFESSIONAL and PREMIUM 30 cm

Electrical screens

Manual screens

PROFESSIONAL electrical built-in RF
Ref.no. 7-5505xx
page 81

PROFESSIONAL electrical RF
Ref.no. 7-5504xx, 7-5506xx
page 82

PREMIUM electrical RF
Ref.no. 7-5517xx, 7-5518xx
page 83





PREMIUM electrical
Ref.no. 7-5530xx, 7-5531xx
page 83

ECONOMY electrical
Ref.no. 7-5567xx, 7-5568xx
page 84

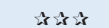
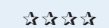
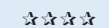
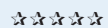
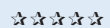
PROFESSIONAL manual CSR
Ref.no. 7-5434xx
page 85

PROFESSIONAL manual
Ref.no. 7-5436xx, 7-5437xx
page 86



		Manual screens		Mobile (tripod) and portable screens				
		PREMIUM manual Ref.no. 7-5401xx, 7-5400xx page 87	ECONOMY manual Ref.no. 7-5446xx, 7-5447xx page 88	PROFESSIONAL mobile portable deluxe Ref.no. 7-5311xx page 89	PROFESSIONAL mobile Ref.no. 7-5306xx, 7-5307xx page 90	PREMIUM mobile Ref.no. 7-5312xx page 91	ECONOMY mobile portable Ref.no. 7-5313xx page 92	ECONOMY mobile Ref.no. 7-5314xx, 7-5315xx page 93
Install (Easy Install)								
CSR (controlled screen return)								
Motor operation								
TÜV								
CE		✓		✓	✓	✓		
Intensive use	★ ★ ★ ★ ★			✓	✓			
Regular use	★ ★ ★ ★	✓				✓		
Occasional use	★ ★ ★		✓				✓	✓
1: 1 format		✓	✓		✓	✓		✓
4: 3 format		✓	✓	✓	✓		✓	✓
16: 9 format		✓						
16:10 format								
1:1 aspect ratio: on the left and on the right side		✓	✓		✓	✓		
4:3 / 16:10 / 16:9 aspect ratio: on the left, right, bottom and top		✓	✓	✓	✓		✓	✓ (only left and right)
RF (RF= radio frequency)								
7-554500 Ceiling brackets for PROFESSIONAL and PREMIUM M6 100 cm		✓						
7-555200 Ceiling brackets for PROFESSIONAL M8 100 cm								
7-555100 Wall brackets PROFESSIONAL and PREMIUM 75 cm		✓						
7-545400 Wall brackets PROFESSIONAL and PREMIUM 30 cm		✓						

Other accessories available on request.



Index alphabetical order

- Accessory kit for In&Out-Board 123, 125
- Accessory set BASIC kit 23, 75, 141
- Accessory set PROFESSIONAL kit 23, 75, 140
- Accessory set STARTER kit 23, 75, 141

- Bases Legaline PROFESSIONAL** 125
- Board Assistant 23, 75, 131, 139
- Board stands 29
- Boardmarker mini TZ 111 23, 136
- Boardmarker TZ 1 23, 75, 131, 133
- Boardmarker TZ 10 PLUS 23, 75, 131, 134
- Boardmarker TZ 100 23, 75, 131, 134
- Boardmarker TZ 140 23, 75, 131, 135
- Boardmarker TZ 150 23, 75, 131, 135
- Boardmarker TZ 180 23, 75, 131, 135
- Bookshelf unit for Legaline DYNAMIC 66
- Bookshelf unit for Legaline PROFESSIONAL ... 72

- Cardboard laminated planners** 112, 113
- Cardboard planners 112, 113
- Carry bag 50
- Ceiling brackets PROFESSIONAL 100 cm 94
- Ceiling brackets PROFESSIONAL and PREMIUM projection screen 100 cm 94
- Channel stands Legaline PROFESSIONAL 125
- Combiboard ECONOMY 21
- Conference unit ECONOMY 19
- Conference unit ECONOMY^{PLUS} 19
- Conference unit PROFESSIONAL 15
- Corner piece Legaline DYNAMIC 63
- Corner piece Legaline PROFESSIONAL 69
- Coupling kit Legaline PROFESSIONAL 125

- Date line** 110, 148
- Date strip sets 1 / 2 / 3 110, 151
- Divider tape for planboards 110, 150
- Document holders magnetic 122, 148
- Doorplate 129
- Doorplate in-/out 129

- e-Board Interactive DYNAMIC** 67
- EXPORAIL 2 hooks+1 m nylon cord 130
- EXPORAIL 5 m nylon cord 130
- EXPORAIL 6 hooks 130
- EXPORAIL 6 paper grippers 130
- EXPORAIL track 130

- Flipchart accessory STARTER kit 40, 143
- Flipchart BASIC tripod Triangle 39
- Flipchart ECONOMY mobile Triangle 39
- Flipchart ECONOMY tripod Triangle 39
- Flipchart ORION 31
- Flipchart pad holder aluminium 23, 136
- Flipchart paper grid 20 sheets 41, 144
- Flipchart paper plain 20 sheets 41, 144
- Flipchart PREMIUM mobile Triangle 36
- Flipchart PREMIUM tripod Triangle 37
- Flipchart PROFESSIONAL mobile Triangle 36
- Flipchart PROFESSIONAL tripod 34
- Flipchart PROFESSIONAL tripod Triangle 37
- Flipchart SILVERTEC mobil 33
- Flipchart UNIVERSAL mobile Triangle 38
- Flipchart UNIVERSAL tripod Triangle 38
- Flipcharts IMAGINE COLOUR 34
- Flipcharts TAURUS 32

- Glassboards Pure** 10
- Gridboards PROFESSIONAL 14

- In & Out-Board PROFESSIONAL** 123
- Information board PREMIUM 128

- Keyholder showcases ECONOMY** 121

- Label and swoosh IMAGINE COLOUR 13, 34
- Label inserts 150
- Labels IMAGINE COLOUR assorted for whiteboard and flipchart 13, 34
- Laserpointers LX 1, LX 2, LX 3, LX 4 95, 142
- Letter box 129, 153
- Letters and numbers – supplementary sets 129, 153
- Lino-cork bulletin pinboards PROFESSIONAL .. 25
- Lino-cork pinboard for Legaline PROFESSIONAL 70
- Literature rack for Legaline DYNAMIC 66
- Literature rack for Legaline PROFESSIONAL ... 73

- Magic-Chart blackboard** 22, 42, 56, 145
- Magic-Chart flipchart** 22, 42, 56, 145
- Magic-Chart whiteboard** 22, 42, 56, 145
- MagicWipe** 23, 75, 131, 139

- Magnetic arrows 149
- Magnetic blocks 147
- Magnetic circles 149
- Magnetic label holders 150
- Magnetic labelling tape 147
- Magnetic rectangles 149
- Magnetic sheets 147
- Magnetic squares 149
- Magnetic strips 146
- Magnetic symbols assorted 149
- Magnetic tape, self-adhesive 146
- Magnetic triangles 149
- Magnets 23, 41, 69, 131, 146
- Magnets for glassboard PURE 10
- Maps PROFESSIONAL magnetic 126, 127
- Marker holder 23, 75, 131, 139
- Marker tray in plexiglass for glassboard PURE. 10
- Moderation board ECONOMY 49
- Moderation board PREMIUM folding mobile. 49
- Moderation board PREMIUM mobile 48
- Moderation board PROFESSIONAL Mobile 47
- Moderation board PROFESSIONAL Travel 46
- Moderation cards Emoticons 58
- Moderation cards, circles 57
- Moderation cards, clouds 57
- Moderation cards, hexagons 57
- Moderation cards, king-size hexagons 57
- Moderation cards, lozenges 57
- Moderation cards, ovals 57
- Moderation cards, rectangles 57
- Moderation case BASIC 54
- Moderation case COMFORT 53
- Moderation case MOBILE 52
- Moderation case PRACTIC 54
- Moderation case PREMIUM 52
- Moderation case PROFESSIONAL 51
- Moderation case PROFESSIONAL TRAVEL 51
- Moderation case TRAVEL 53
- Moderation kit 55
- Moderation paper brown, white 55
- Moderation pins / Roundhead pins, assorted 58, 145
- Moderation strips for headlines 57
- Multiboard 28, 50

- Nameplates engraved** 117

- Paper roll SILVERTEC 35 m** 41, 144
- Pin cushion, clip-on 58
- Pinboard felt for Legaline DYNAMIC 64
- Pinboard felt for Legaline PROFESSIONAL 71

Index reference number

7-10.... Whiteboards			
7-1000xx Whiteboards PROFESSIONAL.....	14		
7-1001xx Gridboards PROFESSIONAL.....	14		
7-1002xx Conference unit ECONOMY.....	19		
7-1003xx Conference unit PROFESSIONAL.....	15		
7-1004xx Revolving whiteboards PROFESSIONAL.....	15		
7-1005xx Conference unit ECONOMY ^{PLUS}	19		
7-1007xx Glassboards Pure.....	10		
7-1009xx Whiteboards DYNAMIC.....	11		
7-1010xx Whiteboards PREMIUM ^{PLUS}	16		
7-1016xx Whiteboards IMAGINE COLOUR.....	12		
7-1020xx Whiteboards PREMIUM.....	16		
7-1021xx Whiteboards UNIVERSAL ^{PLUS}	17		
7-1022xx Whiteboards UNIVERSAL.....	17		
7-1024xx Combiboard ECONOMY.....	21		
7-1027xx Whiteboards ECONOMY ^{PLUS}	18		
7-1028xx Whiteboards ECONOMY.....	18		
7-1029xx Whiteboards BASIC.....	22		
7-1031xx Whiteboards ACCENTS.....	21		
7-1035xx Revolving whiteboards ECONOMY ^{PLUS}	20		
7-1035xx Revolving whiteboards ECONOMY.....	20		
7-11.... Boardmarkers			
7-1100xx Boardmarker TZ 1.....	23, 75, 131, 133		
7-110300 Replacement nibs for TZ 1.....	133		
7-1105xx Boardmarker TZ 100.....	23, 75, 131, 134		
7-1110xx Boardmarker TZ 10 PLUS.....	23, 75, 131, 134		
7-1111xx Boardmarker mini TZ 111.....	23, 136		
7-1119xx Refill cartridge TZ 11.....	136		
7-1125xx Retractable boardmarker TZ 14.....	23, 75, 131, 133		
7-1129xx Refill ink for retractable boardmarker TZ 14.....	23, 75, 136		
7-1140xx Boardmarker TZ 140.....	23, 75, 131, 135		
7-1150xx Boardmarker TZ 150.....	23, 75, 131, 135		
7-1180xx Boardmarker TZ 180.....	23, 75, 131, 135		
7-119xxx Refill ink for boardmarkers.....	23, 75, 136		
7-12.... Accessories for whiteboards			
7-120100 Whiteboard eraser small.....	23, 75, 131, 137		
7-120200 Refill tissues whiteboard eraser small.....	137		
7-120300 Whiteboard eraser magnetic.....	23, 75, 131, 137		
7-120400 Whiteboard eraser, pads for magnetic eraser.....	137		
7-120500 Whiteboard eraser TZ 4.....	23, 75, 131, 137		
7-120600 Refill tissues TZ4.....	137		
7-121000 Whiteboard cleaner TZ 6.....	23, 75, 131, 138		
7-121200 Whiteboard cleaner TZ 7.....	23, 75, 131, 138		
7-121300 Whiteboard cleaner TZ 8.....	23, 75, 131, 138		
7-121400 Whiteboard cleaning wipes TZ 66.....	23, 75, 131, 138		
7-121500 MagicWipe.....	23, 75, 131, 139		
7-122000 Marker holder.....	23, 75, 131, 139		
7-122500 Board Assistant.....	23, 75, 131, 139		
7-123000 Flipchart pad holder aluminium.....	23, 136		
7-124900 Flipchart accessory STARTER kit.....	40, 143		
7-125000 Accessory set STARTER kit.....	23, 75, 141		
7-125100 Accessory set BASIC kit.....	23, 75, 141		
7-125500 Accessory set PROFESSIONAL kit.....	23, 75, 140		
7-125xxx Label and swoosh IMAGINE COLOUR.....	13, 34		
7-1266xx Labels IMAGINE COLOUR assorted for whiteboard and flipchart.....	13, 34		
7-126700 Marker tray in plexiglass for glassboard PURE.....	10		
7-14.... Pinboards			
7-1401xx Lino-cork bulletin pinboards PROFESSIONAL.....	25		
7-1402xx Pinboards DYNAMIC blue felt.....	24		
7-1403xx Pinboards DYNAMIC grey felt.....	24		
7-1405xx Pinboards PROFESSIONAL blue felt.....	25		
7-1406xx Pinboards PROFESSIONAL grey felt.....	25		
7-1410xx Pinboards PREMIUM cork.....	26		
7-1415xx Pinboards PREMIUM blue felt.....	26		
7-1416xx Pinboards PREMIUM grey felt.....	26		
7-1418xx Pinboards UNIVERSAL blue felt.....	27		
7-1419xx Pinboards UNIVERSAL grey felt.....	27		
7-1420xx Pinboards UNIVERSAL cork.....	27		
7-145299 Push pins, assorted.....	75, 131, 145		
7-15.... Flipcharts			
7-150000 Flipchart ORION.....	31		
7-1502xx Flipcharts TAURUS.....	32		
7-1503xx Flipcharts IMAGINE COLOUR.....	34		
7-151000 Flipchart SILVERTEC mobil.....	33		
7-152000 Flipchart PROFESSIONAL tripod.....	34		
7-152700 Flipchart BASIC tripod Triangle.....	39		
7-152800 Flipchart ECONOMY tripod Triangle.....	39		
7-152900 Flipchart UNIVERSAL tripod Triangle.....	38		
7-153000 Flipchart PREMIUM tripod Triangle.....	37		
7-153100 Flipchart PROFESSIONAL tripod Triangle.....	37		
7-153200 Flipchart ECONOMY mobile Triangle.....	39		
7-153300 Flipchart UNIVERSAL mobile Triangle.....	38		
7-153400 Flipchart PREMIUM mobile Triangle.....	36		
7-153500 Flipchart PROFESSIONAL mobile Triangle.....	36		
7-15.... Accessories for flipcharts			
7-1550xx Presentation Marker TZ 41.....	41, 59, 75, 142		
7-1555xx Presentation Marker TZ 48.....	41, 59, 75, 142		
7-1558xx Refill ink presentation marker TZ 41.....	41, 59, 75, 142		
7-1559xx Refill ink presentation marker TZ 48.....	41, 59, 75, 142		
7-156000 Flipchart paper plain 20 sheets.....	41, 144		
7-156500 Flipchart paper grid 20 sheets.....	41, 144		
7-156900 Paper roll SILVERTEC 35 m.....	41, 144		
7-159000 Magic-Chart flipchart.....	22, 42, 56, 145		
7-159100 Magic-Chart whiteboard.....	22, 42, 56, 145		
7-159200 Magic-Chart blackboard.....	22, 42, 56, 145		
7-16.... Interactive products			
7-1606xx e-Board Interactive DYNAMIC.....	67		
7-17.... Stands and easels			
7-171x00 Board stands.....	29		
7-172300 Tripod easel.....	29		
7-18.... Magnetic accessories			
7-181xxx Magnets.....	23, 41, 69, 131, 146		
7-181600 Magnets for glassboard PURE.....	10		
7-184000 Magnetic blocks.....	147		
7-185400 Magnetic strips.....	146		
7-186xxx Magnetic tape, self-adhesive.....	146		
7-187xxx Magnetic labelling tape.....	147		
7-189000 Magnetic sheets.....	147		
7-19.... PROFESSIONAL e-Board FLEX			
7-1900xx Projection board PROFESSIONAL FLEX.....	80		
7-20.... Moderation boards			
7-202x00 Moderation board PROFESSIONAL Mobile.....	47		
7-203x00 Moderation board PROFESSIONAL Travel.....	46		
7-204x00 Moderation board PREMIUM mobile.....	48		
7-205x00 Moderation board PREMIUM folding mobile.....	49		
7-207x00 Moderation board ECONOMY.....	49		
7-21.... Multiboard			
7-210x00 Multiboard.....	28, 50		
7-22.... Moderation cases			
7-220100 Moderation case MOBILE.....	52		
7-220300 Moderation case COMFORT.....	53		
7-220500 Moderation case TRAVEL.....	53		
7-220700 Moderation case PRACTIC.....	54		
7-220900 Moderation case BASIC.....	54		
7-221000 Moderation case PROFESSIONAL TRAVEL.....	51		
7-221100 Moderation case PROFESSIONAL.....	51		
7-221200 Moderation case PREMIUM.....	52		
7-225000 Moderation kit.....	55		
7-23.... Moderation accessories			
7-230100 Carry bag.....	50		
7-240x00 Moderation paper brown, white.....	55		
7-241099 Moderation pins / Roundhead pins, assorted.....	58, 145		
7-242000 Pin cushion, clip-on.....	58		
7-243000 Stickers.....	58		
7-250x00 Moderation cards, clouds.....	57		
7-252xxx Moderation cards, rectangles.....	57		
7-253xxx Moderation cards, circles.....	57		
7-254xxx Moderation cards, ovals.....	57		
7-2550xx Moderation strips for headlines.....	57		
7-256x99 Moderation cards, lozenges.....	57		
7-256x99 Moderation cards, hexagons.....	57		
7-256x99 Moderation cards, king-size hexagons.....	57		
7-25700x Moderation cards Emoticons.....	58		
7-30.... Legaline PROFESSIONAL			
7-3000xx Whiteboard for Legaline PROFESSIONAL.....	70		
7-301154 Lino-cork pinboard for Legaline PROFESSIONAL.....	70		
7-301554 Pinboard blue felt for Legaline PROFESSIONAL.....	71		

7-301654 Pinboard grey felt for Legaline PROFESSIONAL.....	71	7-442x0x Magnetic squares.....	149	7-575x00 Laserpointers LX 1, LX 2, LX 3, LX 4	95, 142
7-304300 Wall rail flipchart for Legaline PROFESSIONAL.....	71	7-443x0x Magnetic circles.....	149	7-60.... Information boards	
7-305100 Bookshelf unit for Legaline PROFESSIONAL.....	72	7-444x0x Magnetic rectangles	149	7-6000xx Information board PREMIUM.....	128
7-305300 TV-video shelf unit for Legaline PROFESSIONAL	72	7-445102 Magnetic triangles.....	149	7-601100 Doorplate.....	129
7-305500 Literature rack for Legaline PROFESSIONAL.....	73	7-446x02 Magnetic arrows	149	7-601200 Doorplate in-/out	129
7-3064xx Projection screen for Legaline PROFESSIONAL.....	73	7-448x0x Magnetic symbols assorted	149	7-605x00 Letter box	129, 153
7-31.... Accessories Legaline PROFESSIONAL		7-45.... Magnetic cardholders		7-606x00 Letters and numbers – supplementary sets	129, 153
7-310x00 Wall rail set for Legaline PROFESSIONAL.....	69	7-450100 Magnetic label holders.....	150	7-61.... Maps	
7-312400 Upper suspension brackets for Legaline PROFESSIONAL.....	69	7-455xxx Label inserts.....	150	7-620500 Accessory kit for In&Out-Board	123, 125
7-313000 Corner piece for Legaline PROFESSIONAL.....	69	7-46.... PROFESSIONAL channel planners		7-620x00 In & Out-Board PROFESSIONAL.....	123
7-32.... Legaline DYNAMIC		7-4600xx Planner channel PROFESSIONAL	114	7-622500 Nameplates engraved.....	117
7-320xxx Whiteboard for Legaline DYNAMIC	64	7-465xxx Planning accessory, basic set	114	7-622x00 In & Out-Board PROFESSIONAL.....	123
7-321xxx Pinboard felt for Legaline DYNAMIC	64	7-466x99 Plastic signals.....	115	7-63.... Showcases	
7-324x00 Wall rail flipchart for Legaline DYNAMIC	65	7-467100 Planning strips.....	115	7-63005x Showcases PROFESSIONAL.....	119
7-325x00 Bookshelf unit for Legaline DYNAMIC	66	7-467xxx Planning strip set	115	7-6306xx Showcases outdoor PREMIUM	119
7-325x00 TV-video shelf unit for Legaline DYNAMIC	66	7-475xxx T-cards	117	7-6317xx Showcases ECONOMY.....	121
7-325x00 Literature rack for Legaline DYNAMIC	66	7-47xx00 Planning modules	116, 117	7-6325xx Keyholder showcases ECONOMY... ..	121
7-326xxx Projection screen for Legaline DYNAMIC	67	7-4..... ACCENTS planners		7-632xxx Poster frames PREMIUM.....	122
7-33.... Accessories Legaline DYNAMIC		7-49x000 Planner ACCENTS week	109	7-635xxx Poster frame with stand PREMIUM	122
7-330x00 Wall rail set for Legaline DYNAMIC	63	7-49x500 Planner ACCENTS multi purpose... ..	109	7-6356xx Document holders magnetic..	122, 148
7-332xxx Suspension brackets for Legaline DYNAMIC	63	7-4xx000 Planner ACCENTS year	108	7-63xxx Showcases indoor PREMIUM	120
7-333x00 Corner piece for Legaline DYNAMIC	63	7-4xx500 Planner ACCENTS month	108	7-64.... Display floor system	
7-40.... PROFESSIONAL planners		7-53.... Projection screens		Legaline PROFESSIONAL	
7-400000 Year planner PROFESSIONAL 365 days	98-102	7-530xxx Projection screen PROFESSIONAL mobile tripod	90	7-6402xx Whiteboards double sided Legaline PROFESSIONAL	118
7-409000 Planner PROFESSIONAL activity	104	7-5311xx Projection screen PROFESSIONAL portable/ mobile deluxe	89	7-641xxx Pinboards double sided Legaline PROFESSIONAL	118, 124
7-41.... PREMIUM^{PLUS} planners		7-5312xx Projection screen PREMIUM portable	91	7-642xxx Channel stands Legaline PROFESSIONAL	125
7-410800 Planner PREMIUM ^{PLUS} multipurpose. ..	98	7-531xxx Projection screen ECONOMY portable / mobile	92, 93	7-643x00 Bases Legaline PROFESSIONAL.....	125
7-413500 Planner PREMIUM week	106	7-540xxx Projection screen PREMIUM manual wall / ceiling.....	87	7-645100 Coupling kit Legaline PROFESSIONAL	125
7-414000 Planner PREMIUM project	106	7-5434xx Projection screen PROFESSIONAL manual wall / ceiling CSR	85	7-65.... EXPORAIL	
7-418000 Planner PREMIUM general	107	7-543xxx Projection screen PROFESSIONAL manual wall / ceiling.....	86	7-6501xx EXPORAIL track	130
7-41x000 Planner PREMIUM year... ..	104, 105, 107	7-544xxx Projection screen ECONOMY manual wall / ceiling.....	88	7-655100 EXPORAIL 2 hooks+1 m nylon cord	130
7-42.... Cardboard planners		7-545400 Wall brackets PROFESSIONAL and PREMIUM projection screen 30 cm.....	94	7-655200 EXPORAIL 5 m nylon cord	130
7-42xxxx Cardboard laminated planners	112, 113	7-550xxx Projection screen PROFESSIONAL electrical RF	82	7-655500 EXPORAIL 6 hooks.....	130
7-42xxxx Cardboard planners	112, 113	7-550xxx Projection screen PROFESSIONAL electrical built-in RF.....	81	7-655600 EXPORAIL 6 paper grippers.....	130
7-42xxxx Rolled up planners.....	112, 113	7-551xxx Projection screen PREMIUM electrical (RF).....	83	7-70.... Cabinets	
7-43.... Planning accessories		7-553xxx Projection screen PREMIUM electrical (RF).....	83	7-70280x Presentation cabinet mobile stand ..	74
7-430000 Date line	110, 148	7-554500 Ceiling brackets PROFESSIONAL and PREMIUM projection screen 100 cm	94	7-70300x Presentation cabinet PROFESSIONAL	74
7-430500 Sliding index.....	93	7-555100 Wall brackets PROFESSIONAL and PREMIUM projection screen 75 cm.....	94	7-70400x Presentation cabinet PREMIUM ^{PLUS} ..	74
7-431x00 Planning accessory, calendar strip set.....	110	7-555200 Ceiling brackets PROFESSIONAL 100 cm.....	94		
7-431x00 Date strip sets 1 / 2 / 3	110, 151	7-556xx Projection screen ECONOMY electrical.....	84		
7-433x0x Divider tape for planboards... ..	110, 150	7-5.... Accessories Projection			
7-435x00 Planning set 1 / 2 / 3	111, 151	7-570000 Telescopic pointer, small.....	152		



One-stop shop for performance and know-how.

As a powerful brand within the edding Group, LEGAMASTER is the No.1 choice when it comes to modern, eye-catching visualisation and presentation. Be it in lessons, at seminars, at conferences or in meetings: with a large range of interactive media, flipcharts, whiteboards, pinboards, moderation equipment, planning aids, presentation and display systems and accessories for bold writing and drawing, LEGAMASTER offers all manner of possibilities.

Legamaster International B.V.
Kwinkweerd 62 · Postbus 111 · 7240 AC Lochem
tel.: (+31) (0)573-71 3000 · fax: (+31) (0)573-71 3001
email: info@legamaster.com · internet: www.legamaster.com

Legamaster 
We make communication visible